

TM 5-325

WAR DEPARTMENT

TECHNICAL MANUAL

ENEMY LAND MINES
AND
BOOBY TRAPS

April 19, 1943



Do not call
just
Man line

TECHNICAL MANUAL

ENEMY LAND MINES AND BOOBY TRAPS



CHANGES }
No. 1 }

WAR DEPARTMENT,
WASHINGTON 25, D. C., 30 July 1943.

TM 5-325, 19 April 1943, is changed as follows:

CHAPTER 1

GENERAL

6. Definitions.

* * * * *

c. Booby traps.—Booby traps are * * * or booby trap. The classification is determined by the purpose for which installed. (See sec. III, ch. 1.) Booby traps * * * an unwary enemy.

* * * * *

[A. G. 300.7 (26 May 43).] (C 1, 30 Jul 43.)

CHAPTER 2

GERMAN LAND MINES AND DEVICES

22. General.—Unlike the British * * * and booby traps. However, a special type of igniter is used with the original model of the Fellermine.

[A. G. 300.7 (26 May 43).] (C 1, 30 Jul 43.)

24. Friction igniter B. Z. E. with delay pellet (fig. 3).

* * * * *

[A. G. 300.7 (26 May 43).] (C 1, 30 Jul 43.)

FIGURE 3.—Friction Igniter B. Z. E. with delay pellet.

[A. G. 300.7 (26 May 43).] (C 1, 30 Jul 43.)

25. Friction igniters B. Z. 24 and Nb. B. Z. 38 with delay pellets (fig. 5).—

a. Description.—These German friction igniters are used generally to ignite grenades through a fuze or detonator. They consist of a lead tube or sheath (1) connected to a threaded brass fitting (2) by a short steel tube (3). The steel tube * * * in the igniter.

b. Employment.—The igniter type B. Z. 24 is generally used with the German "stick grenade" (fig. 4) and the type Nb. B. Z. 38 is used with the smoke grenade (not shown). When used with * * * the smoke grenade. Installations have been found in North Africa where a shorter delay pellet has been substituted for the stand-

ard pellet, thus rendering the stick grenade and egg grenades highly dangerous when used in booby trap installations, especially when inspected. This work should be undertaken by trained personnel.

* * * * *

[A. G. 300.7 (26 May 43).] (C 1, 30 Jul 43.)

FIGURE 5.—Friction igniters B. Z. 24 and Nb. B. Z. 38 with delay pellets.

[A. G. 300.7 (26 May 43).] (C 1, 30 Jul 43.)

27. Pull and tension wire igniter Z. u. Z. Z. 35 (fig. 7).

* * * * *

[A. G. 300.7 (26 May 43).] (C 1, 30 Jul 43.)

FIGURE 7.—Pull and tension wire igniter Z. u. Z. Z. 35.

[A. G. 300.7 (26 May 43).] (C 1, 30 Jul 43.)

28. Pressure igniter D. Z. 35 (fig. 8).

* * * * *

b. Description of large type (fig. 8 (A)).—The large type is identified by the British as type “A” and is fired by a pressure of 130 to 165 pounds. The igniter body (1) * * * directly over it.

c. Description of small type (fig. 8 (B)).—The small type is identified by the British as type “B”. This type is * * * igniter described above.

Subparagraphs *c*, *d*, and *e* are relettered *d*, *e*, and *f*.

[A. G. 300.7 (26 May 43).] (C 1, 30 Jul 43.)

29. Pressure igniter S Mi. Z. 35 (fig. 9).—*a. Description.*—This German pressure * * * lower housing (3). The upper housing (1) contains the pressure spring (2) and the plunger (6) which has three steel antennae (7) each approximately 1¼ inches long. The upper housing (1) also acts as an upper guide for the plunger. The middle housing * * * of the screw (16). The ball (14), seated in the groove in the safety pin, prevents the safety pin from accidentally falling out of the plunger when the nut (15) is removed.

* * * * *

c. Operation.—The igniter is * * * the striker pin. The balls fall into the chamber below the shoulder of (5) and the striker is then released and is propelled downward by the striker spring, setting off the percussion cap (4). A pressure of approximately fifteen pounds on an antenna will operate the igniter. It is reported, however, that pressures between six and one-half pounds and

twelve pounds have fired the igniter when employed with the antipersonnel bounding mine.

* * * * *

LAST 1/4"
TURNED
TO FORM
A GRIP

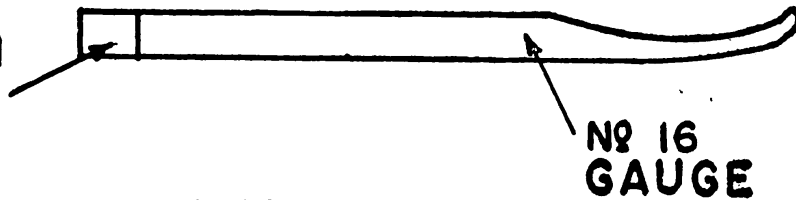

FIGURE 13.1.—Substitute tool for claw.

30. Combined igniter Z. D. Z. 29 (figs. 10 and 11).

* * * * *

c. Operation.

* * * * *

(2) *Pressure igniter set to operate at 100 pounds (fig. 11 (B)).*—To set the igniter to fire at this pressure, turn the movable head so that the mark (20) is opposite “45 kg.” See section C-C, * * * as previously described.

* * * * *

[A. G. 300.7 (26 May 43).] (C 1, 30 Jul 43.)

31. **Pressure igniter T. Mi. Z. 35** (figs. 12 and 13).—*a. Description.*—(1) According to available * * * under “SCHARF” (armed). A slot is provided on the setting dial (10) to permit turning. A brass cap, not shown, is screwed over the base of the igniter to protect the threads on the body (1) from damage.

(2) *Igniter safety devices.*—The igniter has * * * the cylindrical body (3). The safety bolt (12) is moved in or out of the “safe” position by means of a claw (14) to which is attached a flexible wire 5 feet long. Section A-A (fig. 13) * * * the shear pin. In this position the full compression of the spring (7) is resisted only by the shear pin (8).

* * * * *

c. *Operation.*—To arm this igniter * * * the percussion cap. The percussion cap (6) when ignited, shoots a flame through the bottom of the igniter and ignites the detonator below. **The British have found in tests that the normal shearing strength of the shear pin (8) is 230 pounds.**

d. *To neutralize.*—The neutralizing procedure * * * their “safe” position. **The British have designed a simple tool, shown**

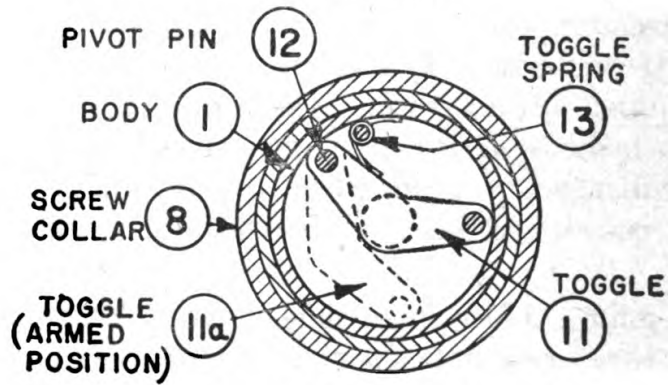
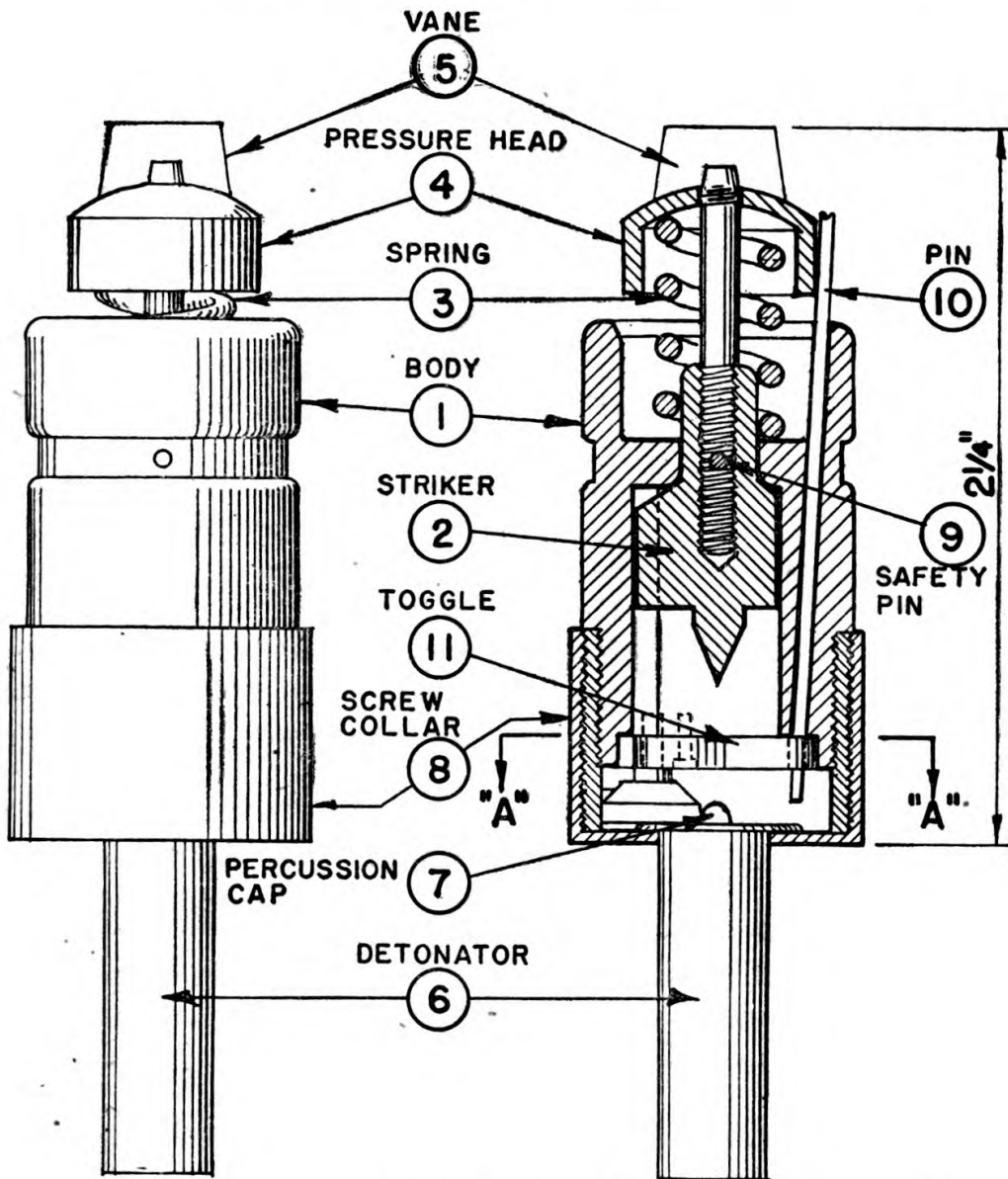

SECTION "A-A"

FIGURE 14.1.—PX32 push igniter.

in figure 13.1, as a substitute for the claw (14) (see fig. 13) which may be used in neutralizing the standard Tellermine igniter T. Mi. Z. 35. Although the instructions given in (1) below are based on enemy documents, the British in their latest reports recommend that this igniter be removed from the Tellermine before any attempt is made to manipulate the igniter safety devices.

* * * * *

[A. G. 300.7 (26 May 43).] (C 1, 30 Jul 43.)

32.1 (Added). PX 32 push igniter (fig. 14.1).—This igniter was described in a report dated December 1942 in which it was stated that up to that date it had not been used by the enemy. However, it was expected to be used in the future.

a. Description.—This igniter consists of a cylindrical metal body (1) in which is housed a striker (2). The striker (2) is held in the cocked position by the compression of a spring (3) which is confined between a recess in the body (1) and a pressure head (4) screwed to the striker shaft and supporting a small metal vane (5). At the other end of the body (1) is fitted a standard (German) No. 8 detonator (6) and percussion cap (7) by means of a screw collar (8). The igniter is provided with two safety devices, a safety pin (9) which is inserted through the body (1) and striker (2), and a pin (10) which is inserted through the wall of the body (1) and through a hole in a toggle (11). The toggle covers the percussion cap (7), and pivots on a pin (12). When the pin (10) is removed, a spring (13) swings the toggle (11) to the position (11a) shown by dotted lines and uncovers the percussion cap (7).

b. Employment.—As yet no employment of this igniter has been reported. However, it could be used in improvised mines.

c. Operation.—When the safety pins (9) and (10) are removed the igniter is armed. Pressure applied to the head (4) forces the striker (2) onto the percussion cap (7) and fires it. In turn, the detonator (6) is ignited, thus exploding the charge to which it is attached.

d. To neutralize.—The igniter may be neutralized by replacing the safety pin (9) in the hole through the body (1) and the striker (2).

[A. G. 300.7 (26 May 43).] (C 1, 30 Jul 43.)

32.2 (Added). Weissman igniter (fig. 14.2).—This igniter was described in a report dated December 1942, in which it was stated that up to that date it had not been used by the enemy. However, it was expected to be used in the future.

a. Description.—This igniter consists of a cylindrical metal body (1) which houses a striker (2). The striker (2) is provided with a

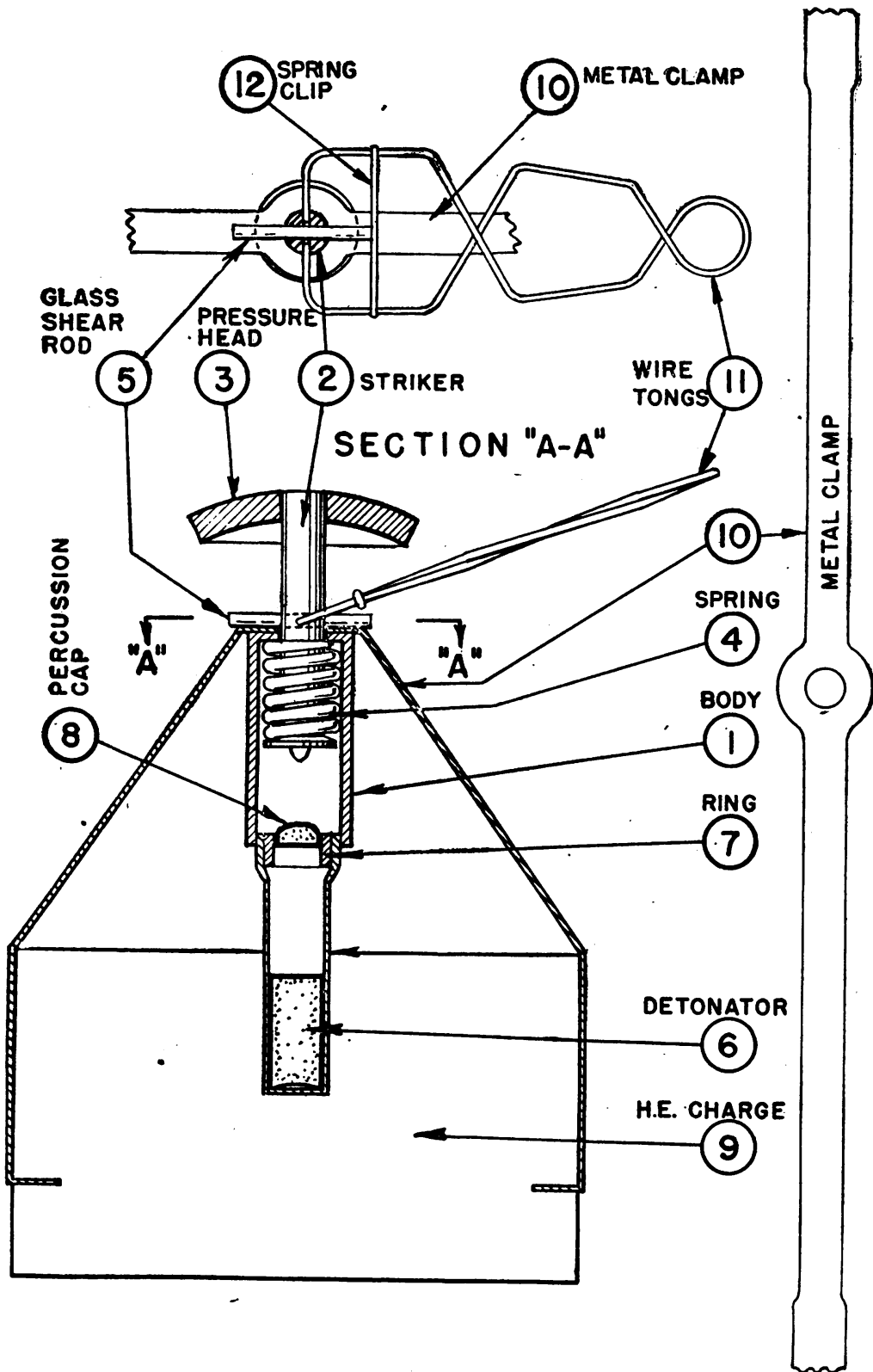

FIGURE 14.2.—Weissman igniter.

pressure head (3) and is held in a cocked position by means of a compression spring (4) and a glass shear rod (5), passing through a hole in the striker (2). A No. 8 (German) detonator (6) is inserted in the open end of the body (1) and holds a ring (7) into which is fitted a percussion cap (8). The detonator (6) is inserted into a HE (high explosive) charge (9) and the igniter is fastened to the charge by means of a thin metal clamp (10). A safety device is provided which consists of a small pair of wire tongs (11), the jaws of which fit into a hole in the striker (2) and are held in place by a spring clip (12).

b. Employment.—This igniter is designed to be used as a push igniter for improvised mines, or as an impact igniter for HE (high explosive) charges (Geballte Ladungen, charge in shape of a ball) when used in the assault.

c. Operation.—When the tongs (11) are unclamped from the striker (2) by slipping back the spring clip (12) the igniter is armed. When pressure is applied to the pressure head (3) the glass shear rod (5) breaks, and the spring (4) drives the striker onto the percussion cap (8) which fires the detonator (6) and, in turn, the charge (9).

d. To neutralize.—If a pair of tongs (11) is available, very carefully reclamp them in place on the striker (2) and lock the tongs with the clip (12). If the tongs (11) are not available, a piece of wire should be bent to fit into the holes in the striker (2) and bound in place. As the shear rod (5) is glass, *be very careful not to exert any pressure on the pressure head (3).*

[A. G. 300.7 (26 May 43).] (C 1, 30 Jul 43.)

32.3 (Added). Igniter E. S. Mi. Z. 40 (electrical) (figs. 14.3, 14.4, and 14.5).—This igniter is designed for use with the antipersonnel bounding mine (silent soldier) described in paragraph 48. It consists of two “chains” of nine initiating igniters apiece, connected in parallel to a firing bridge attached to the mine. Each initiating igniter is a pressure igniter which uses a chemical action to create a flash in the firing bridge.

a. Description.—The igniter assembly is made up of two parts: the Initiating Igniter and the Firing Bridge. Following is a description of each.

(1) *Initiating igniter (fig. 14.3).*—Each igniter consists of an ebonite body (1) which incloses a mechanical firing assembly, and an ebonite spike (2). The firing assembly is a ball release device and consists of a two part housing (3) screwed into the body (1), a plunger tube (4) and a striker (5). The plunger tube (4) is held up by a spring (6), and the striker (5) is held in the cocked position by a

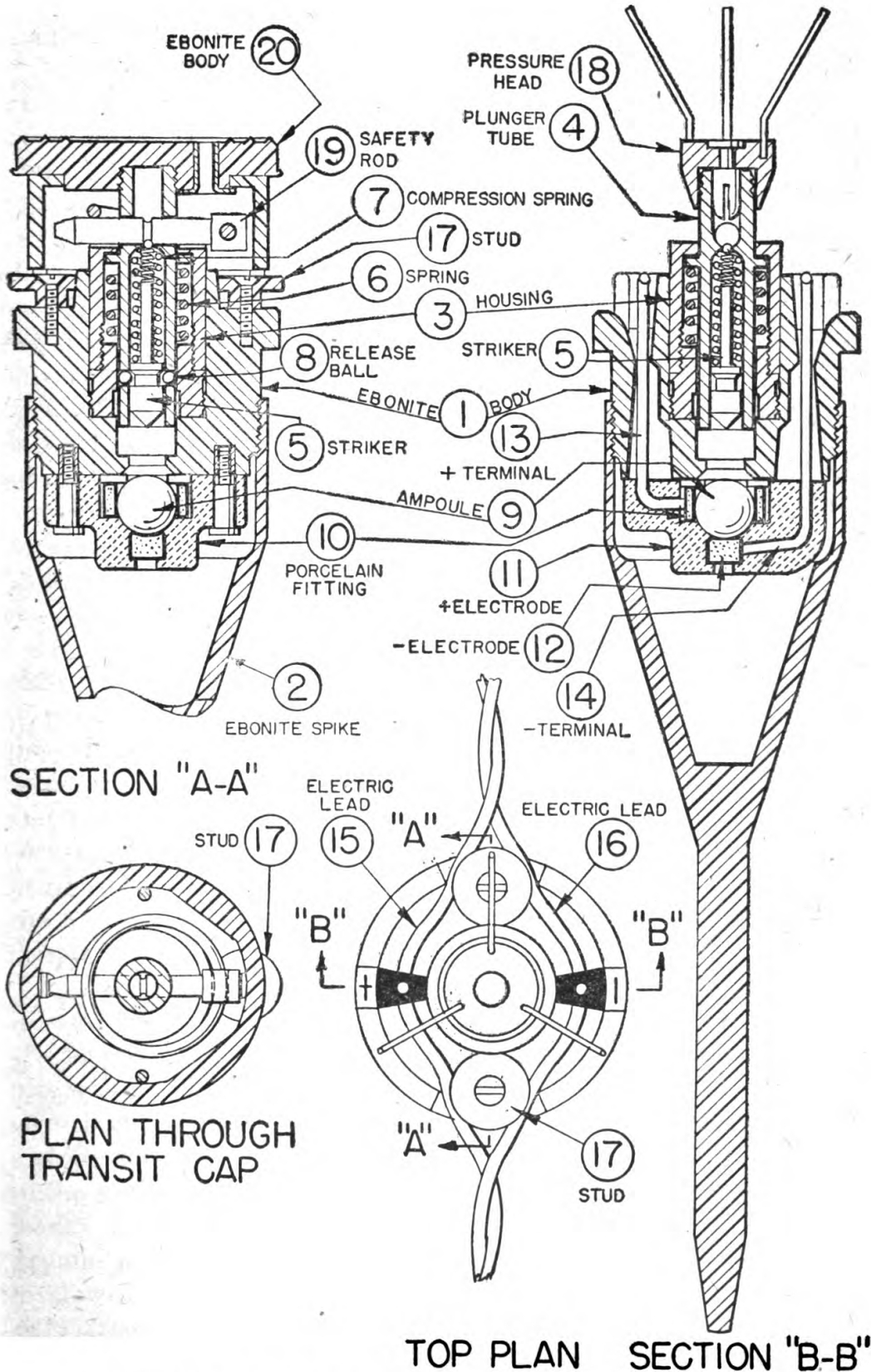

FIGURE 14.3.—Igniter E. S. Mi. Z. 40 (electrical) initiating igniter.

compression spring (7) and two balls (8) engaging a groove in the head of the striker (5). An ampoule (9) takes the place of a percussion cap and is held in a recess formed in a porcelain fitting (10) which is fastened by studs to the body (1). The ampoule (9) contains an orange colored liquid, which, when the ampoule (9) is broken, forms an electrolyte for a small cell, the electrodes (11) and (12) of which are provided by the lining of the recess in the fitting (10). Electrode (11) is connected to the positive terminal (13) and electrode (12) to the negative terminal (14). To the terminals (13) and (14) are connected two electrical leads (15) and (16) which are held to the igniter by means of the studs (17). A three-pronged pressure head (18) with a sleeve fit is pressed into the top of the plunger tube (4). In the unarmed condition, a safety rod (19) is fitted through the top of the plunger tube (4) and positioned by a spring actuated ball catch. The ring of the safety rod is folded over the plunger tube (4) and an ebonite safety transit cap (20) is screwed onto plunger tube (4). When the igniter is located in very soft earth, a circular plate (21) (see fig. 14.4) is provided through which the spike (2) is driven.

(2) *Firing bridge (fig. 14.4).*—The device consists of a bridge (22) with an electric flash housed in an aluminum tube (23) which is protected in transit by a cap piece (24). The bridge (22) is provided with terminal sockets (25) into which plugs (26) are inserted. One socket is colored red and receives the red colored plug and the other socket is colored black and receives the black colored socket. The plugs (26) are protected in transit by caps (27). The bridge (22) is screwed onto the detonator tube (7) (see fig. 37) of the antipersonnel bounding mine which is then set into a U-shaped clamp (28) which also grips the plugs (26).

b. Employment and installation (figs. 14.3 and 14.5).—This igniter is used with the standard German antipersonnel bounding mine ("silent soldier") in the following manner: Two chains of nine igniters each (29) are wired up in parallel with 2 feet 7½ inches of wire between each igniter and 5 feet 3 inches of wire between the end igniter in each chain and the plug (26). Two furrows are made in the ground on either side of the mine (30) to receive the electrical leads (15) and (16). The igniters (29) are then driven into the ground until the top of the safety transit cap (20) (see fig. 14.3) is level with the ground. If the ground is soft, use the circular plate (21) (see fig. 14.4) with the spike (2). Test the leads with a lead tester by plugging in the plugs (26) into the tester and short circuiting the most distant igniter (29). Unscrew the safety transit c

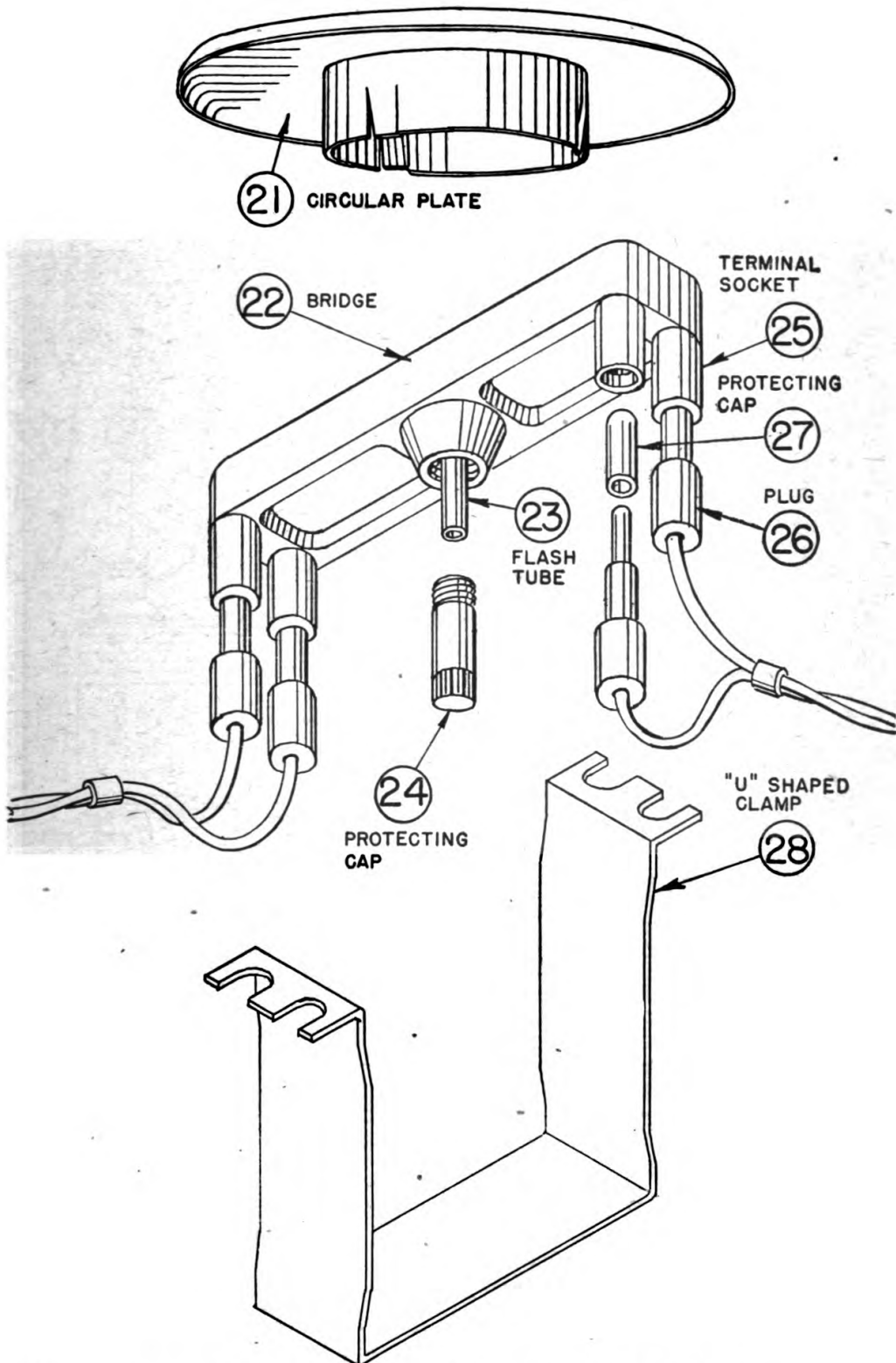

FIGURE 14.4—Igniter E. S. Mi. Z. 40 (electrical) firing bridge.

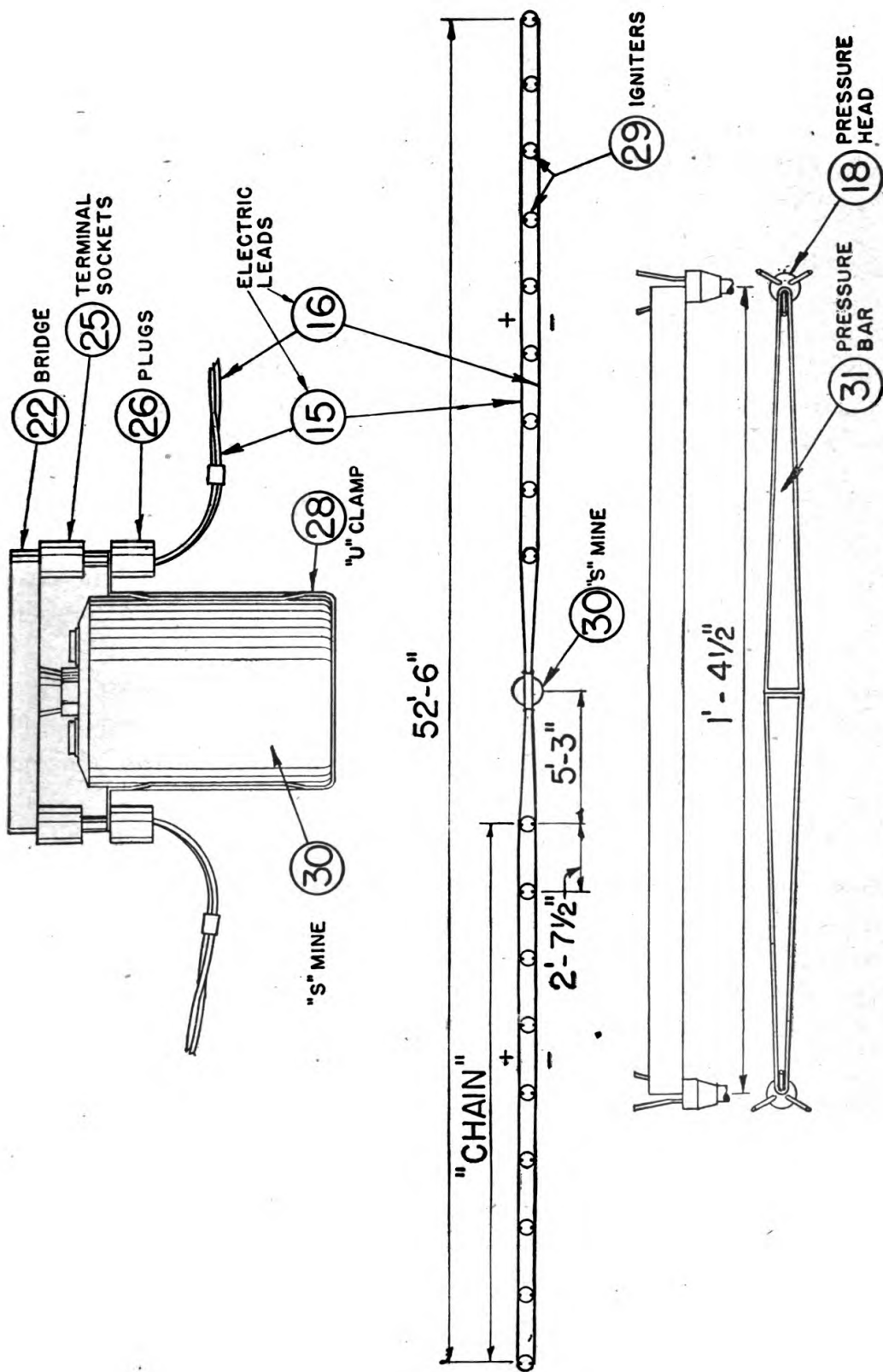

FIGURE 14.5.—Laying igniter E. S. Mi. Z. 40 (electrical).

(20) and release the safety pin rings from engagement with the plunger tubes and clip withdrawal cords onto the rings. Screw the bridge (22) onto the mine and place the mine in the holder (28). Insert the plugs (26) in the sockets (25), red to red and black to black, and push them home. If required, a pressure bar (31), 1 foot 4½ inches long, can be placed on one prong each of adjacent igniters (29) which are also spaced at 1 foot 4½ inches to correspond with the length of the pressure bar (31).

c. Operation.—When one of the initiating igniters (29) or the pressure bar (31) is stepped on, the plunger (4) is depressed until the balls (8) are released into a groove formed in the housing (3). The striker (5) is thus released and the compression spring (7) drives it onto the ampoule (9) which is broken. The liquid then creates an electric current which induces a flash in the tube (23) which fires the mine.

d. To neutralize.—When a “chain” of initiating igniters E. S. Mi. Z. 40 is discovered, trace the electrical leads (15) and (16) to the mine and pull out all the plugs (26) from their sockets (25) in the bridge (22).

[A. G. 300.7 (26 May 43).] (C 1, 30 Jul 43*)

37. Bore-hole charge model 28 (fig. 17 (A)).—*a. Description.*—This is the smallest * * * located in one end. This charge is also known as the 100 Gm. prepared bore-hole charge.

* * * * *

[A. G. 300.7 (26 May 43).] (C 1, 30 Jul 43.)

38. Explosive charge model 28 (fig. 17 (B)).—*a. Description.*—This is a block-shaped * * * block of TNT. The threaded receptacle (1) to receive the detonator is located in one of the large faces. This charge is also known as the 200 Gm. prepared charge.

* * * * *

[A. G. 300.7 (26 May 43).] (C 1, 30 Jul 43.)

39. Metal container HE (high explosive) charge, model 24 (fig. 17 (C)).—*a. Description.*—This German charge * * * any desired weight. This charge is also known as the 1 kg. prepared charge.

* * * * *

[A. G. 300.7 (26 May 43).] (C 1, 30 Jul 43.)

40. Three kilogram HE (high explosive) charge (fig. 17 (D)).

* * * * *

b. Employment.—This charge is * * * heavy demolition work. It is also used in improvised mines and for demolition of aircraft.

[A. G. 300.7 (26 May 43).] (C 1, 30 Jul 43.)

41. Ring charge for gun demolition (fig. 18).—*a. Description.*—This German charge * * * like a half-circle. The German designation for the small charge is *Hohlringladung 1.2 kg.* and for the large charge, *Hohlringladung 3.2 kg.* These charges are also known as hollow ring demolition charges.

* * * * *

[A. G. 300.7 (26 May 43).] (C 1, 30 Jul 43.)

42. Demolition charges for armored structures (fig. 19).—*a. Description.*—There are two sizes of this type of German charge, the small type designated as *Hohlladung* and the large type designated as *Hohlladung 50 kg.*

* * * * *

[A. G. 300.7 (26 May 43).] (C 1, 30 Jul 43.)

42.1 (Added). 13.5-kg shaped demolition charge (with legs) (fig. 19.1).—In addition to the standard demolition charges described in paragraph 42 the Germans used in the Middle East a demolition charge of the “bell” type consisting of a container (1) inclosing a 30-pound charge (2) and provided with a receptacle (3) into which a standard detonator can be screwed. Three folding legs (4) are attached which support the container (1) at a distance from the armor to be perforated. These charges are probably held in reserve for special tasks.

[A. G. 300.7 (26 May 43).] (C 1, 30 Jul 43.)

44. Tellermine or “T” mine (figs. 20 to 24, incl.).

* * * * *

b. Employment.—(1) *General.*—Tellermines are normally * * * a pull igniter. Tellermines also have been found laid upside down, thus making access to igniter (10) more difficult. Tellermines are easy to identify when laid in roads surfaced with “Tarmac” (bituminous compound surfacing). However, they are difficult to identify when laid in hard, beaten tracks where the hole is prepared with an earth auger. They have been found buried in the edge of a road at a depth of 3 feet and thus elude a mine detector. Tellermines thus laid detonated only after several vehicles had made a rut. As Tellermines come two in a carrying case, if one is found, a second Tellermine is probably not far away. Tellermines have been found lying on the surface unmarked with the safety pin (14) (fig. 13) in pla

and the arming wire wrapped around the T. Mi. Z. 35 igniter. Underneath the Tellermines, antilifting devices were attached. In a report dated January 14, 1943, it was stated that the Tellermine was found used in conjunction with the British G. S.

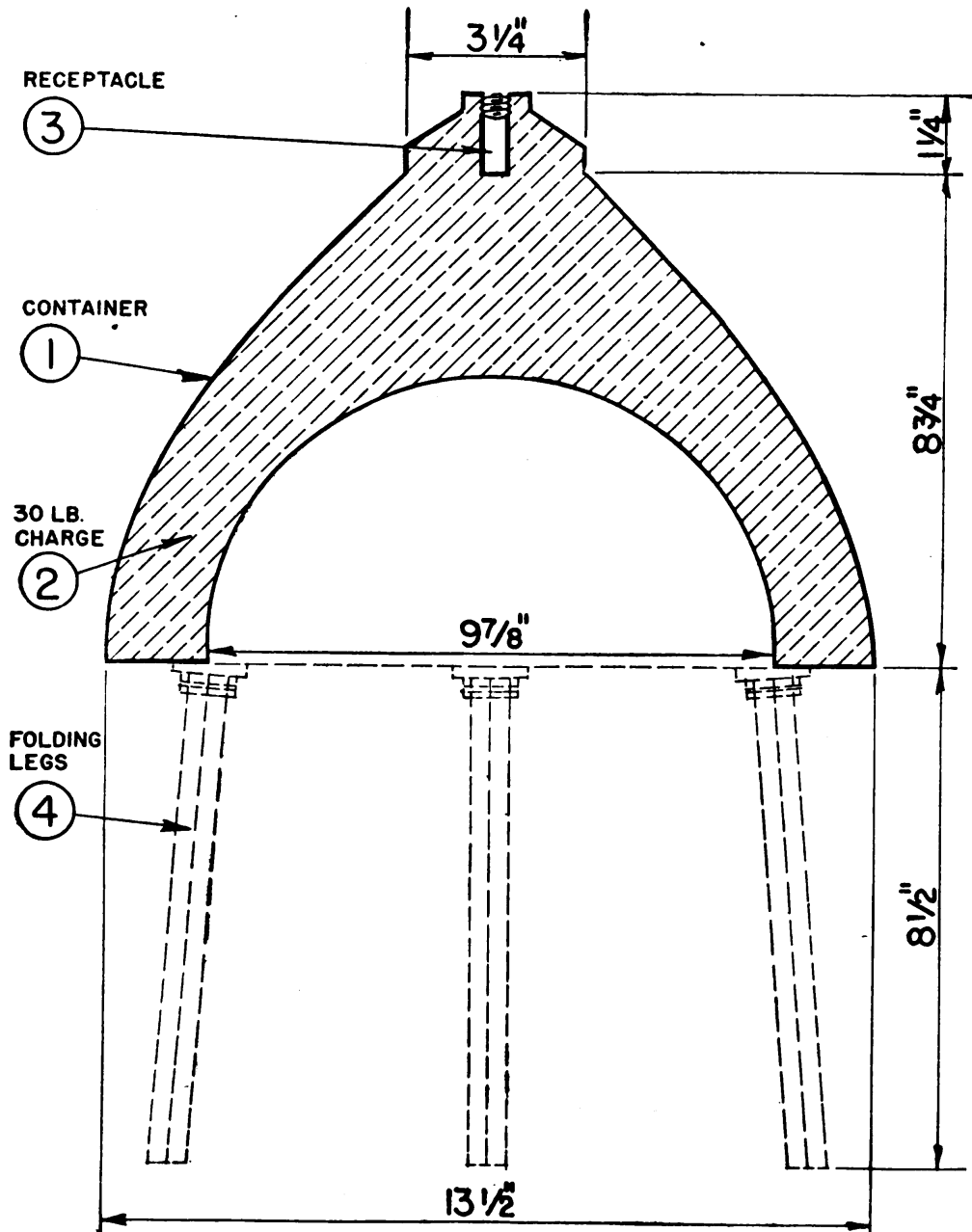

FIGURE 19.1.—13.5 kg. shaped demolition charge (with legs).

Mk. II mine and the E. P. mines (see British land mines and booby trap mechanisms). The G. S. Mk. II mine was laid on top of an inverted Tellermine with about 2 inches of sand between. A fine wire was connected to one of the legs of the G. S. Mk. II mine and to a pull igniter screwed into the base.

of the Tellermine. In the case of the E. P. mines, two or more of them were connected to the Tellermine by primacord.

(2) *Road blocks.*—Tellermines have been found both in paved and unpaved roads. When used as * * * its getting lost. The number of mines connected by the bars (17) may vary from two to six, according to the length of the barrier required. These bars space the individual mines about 5 feet apart.

* * * * *

c. Operation.—Captured German documents state that the firing pressures for this mine vary from 400 to 420 on the center and from 175 to 220 pounds at the edge. When a vehicle passes * * * igniter to fire. Conversely, if the collar (8) is screwed in short of its correct position, less pressure is required on the mine cover and the mine is relatively more sensitive.

d. To disarm.

* * * * *

(2) *Neutralize and remove secondary igniters.*—After the main igniter (10) has been neutralized, dig down beside the mine on the side opposite the handle to ascertain if there is an igniter in the receptacle (13) (see fig. 21). Then dig under * * * handling the mines. Improper installations will cause defective operation as described in *c* above. A Polish field company in the Middle East reports that they found Tellermines which had pull igniters on the side. In this case the handle (15) pointed *upward* (see fig. 21). Where pull igniters were attached only to the bottom, the handle (15) pointed *downward*. The latter position of the handle is contrary to normal practice, as it would tend to interfere with the functioning of the mine under pressure. However, the extra excavation required for placing the additional igniter in the bottom eliminates the danger of the handle's interfering with the operation of the Tellermine. Installations have been found where a friction igniter or a combined push-pull igniter located in the bottom has been connected by a cord to a nail or a second mine underneath. Others have been found where a friction igniter has been connected by a cord to the handle (15) as an antilifting device.

* * * * *

f. To arm.—Proceed in the following order:

(1) *Preliminary* (Superseded).—If the Tellermine should be found disassembled and the standard Tellermine tools are available, the following procedure for arming and setting the Tellermine is used. The setscrew (11) (see fig. 21) is loosened by means of a small screw

driver. The collar (8) and the threaded washer (7) which fits under it are removed using the Tellermine box spanner. After unscrewing, these parts must be carefully removed by hand lest they fall between the container (1) and the pressure cover (2). If this should occur, the Tellermine would have to be dismantled. The detonator (6) is then inserted with the band pointing upward and the protective label undamaged. The threaded washer (7) is then reinserted, screwed into position, and tightened, using the box spanner. The collar (8) is then screwed in but not so tight that it cannot be adjusted up or down easily. In order that the Tellermine may function correctly the interval between the washer (7) and the collar (8) should be between $\frac{1}{16}$ and $\frac{5}{64}$ inch. For this adjustment, the Tellermine adjusting gage is used. The leather or rubber washer (9) is slipped onto the gage as far as the cone on the gage. The gage is then screwed into position in the threaded opening of the cover (2) and tightened. The measuring or adjusting bolt is pressed downward and turned until the adjusting pins engage the holes in the collar (8). There is enough horizontal play in the cover (2) to permit this operation. The measuring bolt on the gage, after loosening, must be able to move upward through the action of the spring in the gage. The mark on the measuring bolt is then brought to the same height as that on the casing of the gage by turning it to the left or right. This adjusts the collar (8) to the correct distance from the washer (7). In doing this, be sure that the measuring bolt is pressed firmly downward so that the measuring surface of the bolt is in good contact with the collar (8). The measuring bolt is then released by action of the spring and the gage is unscrewed. The setscrew (11) is then screwed tight making sure that it does not coincide with one of the sockets in washer (7) underneath. If this occurs, turn the collar (8) $\frac{1}{8}$ inch to the left. Place the sealing ring provided over the head of the collar (8) and place the leather or rubber washer (9) also over the head of the collar (8).

(2) *Preparing main igniter.*—After the main * * * not been displaced. The British make particular note that if the collar (8) has been removed, it cannot be replaced correctly unless the special Tellermine setting tool is available. Unless this collar (8) is correctly positioned the Tellermine is either too sluggish or too sensitive.

* * * * *

[A. G. 300.7 (26 May 43).] (C 1, 30 Jul 43.)

44.1 (Added). **Tellermine No. 2** (fig. 24.1).—Tellermine No. 2 is a simplified design of the original Tellermine (see par. 44) and

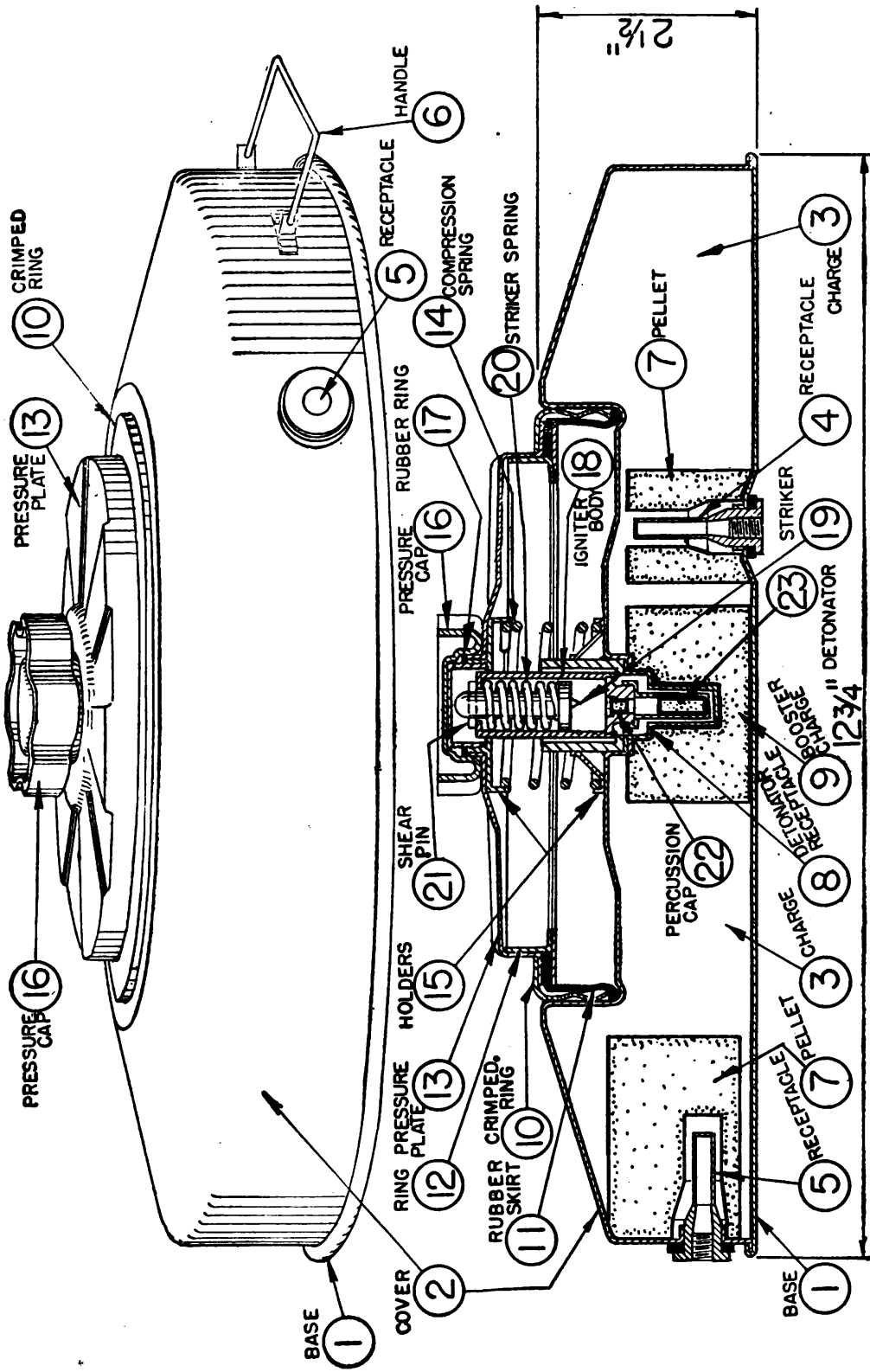

FIGURE 24.1.—Tellermine No. 2.

intended for use as an antitank mine. It employs a simple igniter which is similar to that used in the British R. E. No. 1 mine (see British land mines and booby trap mechanisms). The mine is painted a dark gray with a mat finish.

a. Description.—The Tellermine No. 2 is similar in size and shape to the original Tellermine, being circular in plan with a dome-shaped cover. It is constructed chiefly of pressed steel and consists essentially of a cylindrical body which contains the explosive charge, a pressure plate assembly, and an igniter assembly. The body consists of a circular flat base (1) which is crimped to the cover (2) and contains the main HE (high explosive) charge (3) of 12 pounds of TNT. A receptacle (4), threaded to receive a standard pull igniter, is screwed into the baseplate (1) and is 2 inches offset from the center of the mine. A second receptacle (5), similarly threaded to receive a standard pull igniter, is screwed into the side of the cover (2) and is located 4 inches away from the carrying handle (6). Both openings provided for the receptacles (4) and (5) are made waterproof by use of rubber washers. Cylindrical penthrite pellets (7) are fitted around both receptacles (4) and (5). The cover (2) has a central cylindrical recess into which is fitted the pressure plate assembly. In the center of this recess is fitted a detonator receptacle (8) which is surrounded by the main penthrite booster charge (9) which weighs approximately 6 ounces. The pressure plate assembly consists of a flanged crimped ring (10) which fits tightly into the recess in the cover (2), and restrains pressure plate (13) against the action of compression spring (14). A rubber skirt (11) fits into the cover recess and prevents ingress of dust and moisture. A second ring (12) is spot welded to a corrugated pressure plate (13) and secures the upper edge of the rubber ring (11) to the corrugated pressure plate (13). A strong compression spring (14), positioned at both ends by holders (15), provides the resistance which must be overcome to depress the pressure plate (13). A hexagonal pressure cap (16) with a waterproof rubber ring (17) is screwed into a hole in the center of the pressure plate (13). The igniter assembly consists of a cylindrical body (18), a striker (19), a striker spring (20), and a shear pin (21). A percussion cap (22) is fitted into the lower opening of the body (18) to which is screwed a detonator (23) which is similar to that employed in the original Tellermine.

b. Employment.—This mine is used as an antitank mine and, undoubtedly, its employment is similar to that of the original Tellermine (par. 44b).

c. Operation.—Pressure applied to either the pressure cap (16) or to the pressure plate (13) forces the pressure cap (16) onto the

striker (19) and shears the shear pin (21). The striker (19) is then driven down by the compression of the spring (20) onto the percussion cap (22) and fires it. This, in turn, fires the detonator (23) and the booster charge (9) which detonates the main charge (3). The mine may also be fired if a secondary igniter and detonator is inserted in either or both of the receptacles (4) and (5) and the mine is disturbed or lifted before these igniters are neutralized. The pressure required to fire this mine is not yet known.

d. To disarm the mine.—First, examine carefully the side and bottom of the mine for secondary igniters which may be inserted in either or both receptacles (4) and (5). Secondary igniters should be neutralized and the pull wires cut. It must be stressed at this point that the locations of the secondary igniters on this mine are not the same as on the original Tellermine. Then unscrew the hexagonal pressure cap (16), and remove the main igniter assembly with its detonator (23).

e. To arm the mine.—Examine the shear pin (21) to see whether it has been damaged. If not, replace the igniter assembly together with its detonator (23) in the receptacle (8). Replace the rubber ring (17) and screw the pressure cap (16) in place without exerting any pressure on the pressure plate (12). Secondary igniters may also be screwed into the receptacles (4) and (5) and attached to pull wires.

[A. G. 300.7 (26 May 43).] (C 1, 30 Jul 43.)

44.2 (Added). Tellermine No. 3.—This mine is very similar to the original Tellermine but has a fluted top. It is designed to take either the standard pressure igniter T. Mi. Z. 35 or the igniter assembly of the Tellermine No. 2. If the latter igniter is used, the hole in the cover is closed by a screwed plug with a milled head. No further information has been received on this mine.

[A. G. 300.7 (26 May 43).] (C 1, 30 Jul 43.)

45.1 (Added). Light antitank mine L. Pz. (figs. 26.1 and 26.2).—The British suggest that L. Pz. might mean “Lange Patrone Zunder” meaning, “long cartridge fuze.” This mine, which was first reported as being carried by German paratroops in their attack on Suda Bay, Crete, has now been recovered from an enemy position in the Alamein Line. Due to small differences in the construction of the two, it is assumed that the latter is a new model and our assumption is further justified by the fact that the date 1942 is stamped on it.

a. Description.—The L. Pz. mine is primarily a light antitank mine. It resembles a thick large circular disk with flat top and bottom surfaces, and rounded sides. The mine measures $10\frac{1}{4}$ inches in diameter and is $2\frac{1}{4}$ inches high, exclusive of the cap (18). The housing of the

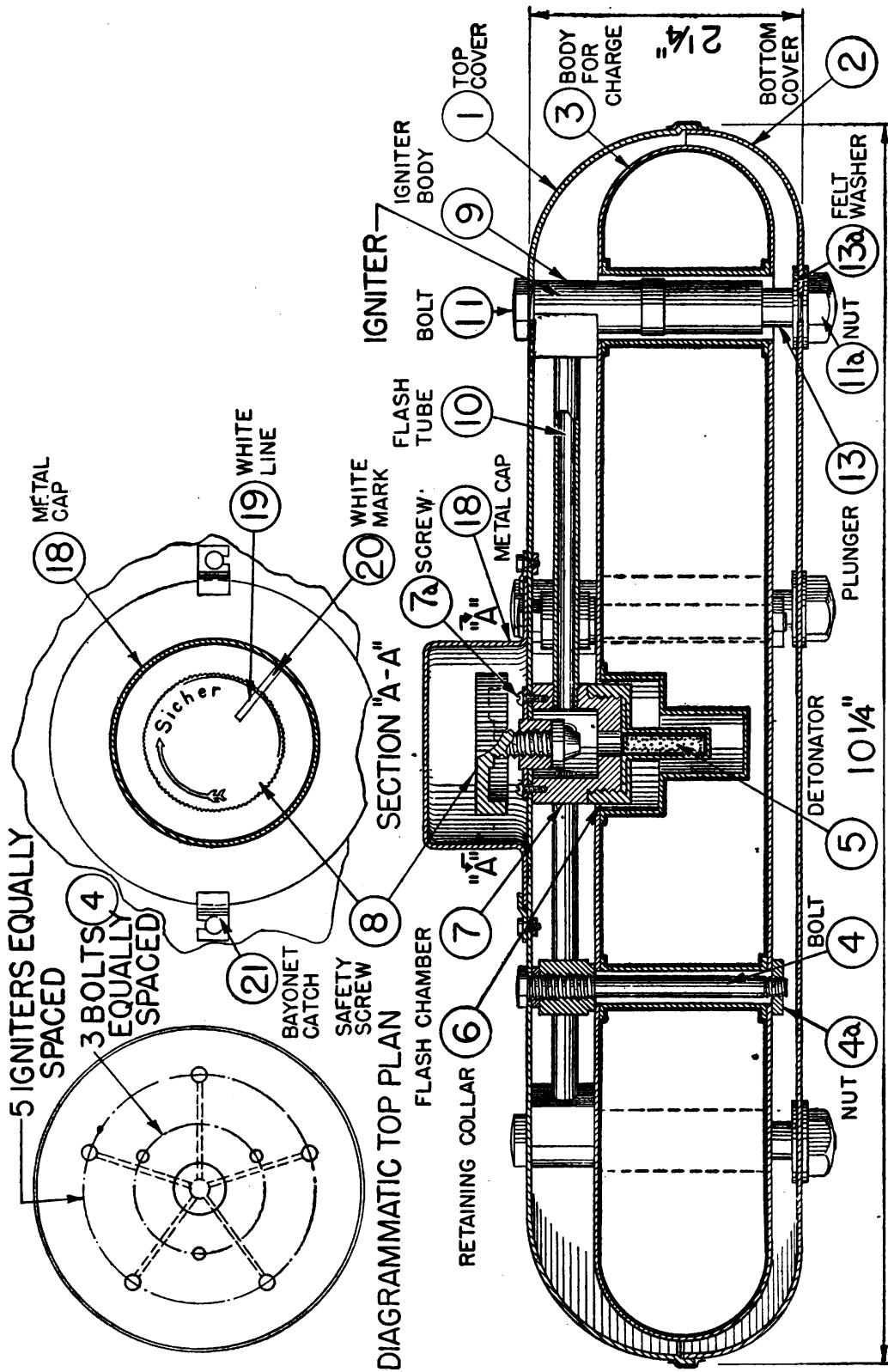

FIGURE 26.1.—Light antitank mine L. Pz. (plan and sections).

mine is of sheet metal. It weighs 9 pounds and contains 5 pounds of TNT explosive. A more detailed description is as follows:

(1) *Main assembly* (fig. 26.1).—The body consists of two saucer-shaped pressed steel top and bottom covers (1) and (2). It contains the explosive body (3), a detonator assembly and five igniter assemblies, all of which are secured to the top cover (1). The bottom cover (2) fits tightly in the lipped rim of the top cover (1) and the joint is sealed with adhesive tape to make the mine waterproof. The cover (2) is further secured by the nuts (11a). The body (3) is a water-tight sheet metal container and holds the explosive filling. It is recessed to provide a socket for the detonator assembly and has five tubes to accommodate five igniters and three more tubes to accommodate three bolts (4) which secure the explosive body (3) to the top cover (1). The detonator (5) is held by a retaining collar (6) which screws into a metal flash chamber (7), attached to the underside of the top cover (1) by means of five screws (7a). The detonator is the standard German detonator employed in the Tellermine and is very sensitive. The igniters are spaced radially (72° apart) around the mine. Each of the igniters is connected to the flash chamber (7) by means of a horizontal brass flame tube (10), about 4½ inches long. The British report that since the flame tube is unusually long, it is probable that a long cartridge fuze is contained in each flame tube (10).

(2) *Igniters* (fig. 26.2).—The igniters are of a push or pressure type and resemble the pressure igniter D. Z. 35 (see par. 28) in an inverted position. Each consists of the igniter tube or body (9), the plunger (13), and the striker mechanism contained within the plunger. The igniter body (9) consists of three separate sections fitted together and fastened to the top cover by means of the bolt (11). From the figure, it appears that this bolt is provided with left-handed threads. A small internal collar (12a) containing the percussion cap (12) fits into the upper section of the body (9) just below the flame tube (10). The middle section of the body (9) serves as an upper guide for the plunger (13). The lower section of the body (9) contains the compression spring (15), which acts as a spacer to restrain free movement between the plunger (13), and the middle section of the body (9); it also acts as a lower guide for the plunger (13). The plunger (13) is a single unit, the upper section of which is hollow and houses the striker assembly. The middle section of the plunger (13) has a flange to serve as a shoulder for the compression spring (15). The lower section is threaded and is attached to the lower cover (2), with the hexagon nut (11a) fitted with a steel washer. A small felt washer (13a) fits inside the cover (2) to make the joint watertight. The

striker assembly consists of the striker (14), the striker spring (16), and two steel pins (17). The striker (14) consists of a striker head formed on a tubular body which houses the striker spring (16). The striker (14) is held in a cocked position by means of the pins (17) which are retained in recesses in the upper section of the plunger (13) and bear against the beveled head of the striker (14). The pins (17) receive the lateral pressure from the striker (14), which is under pressure from the striker spring (16).

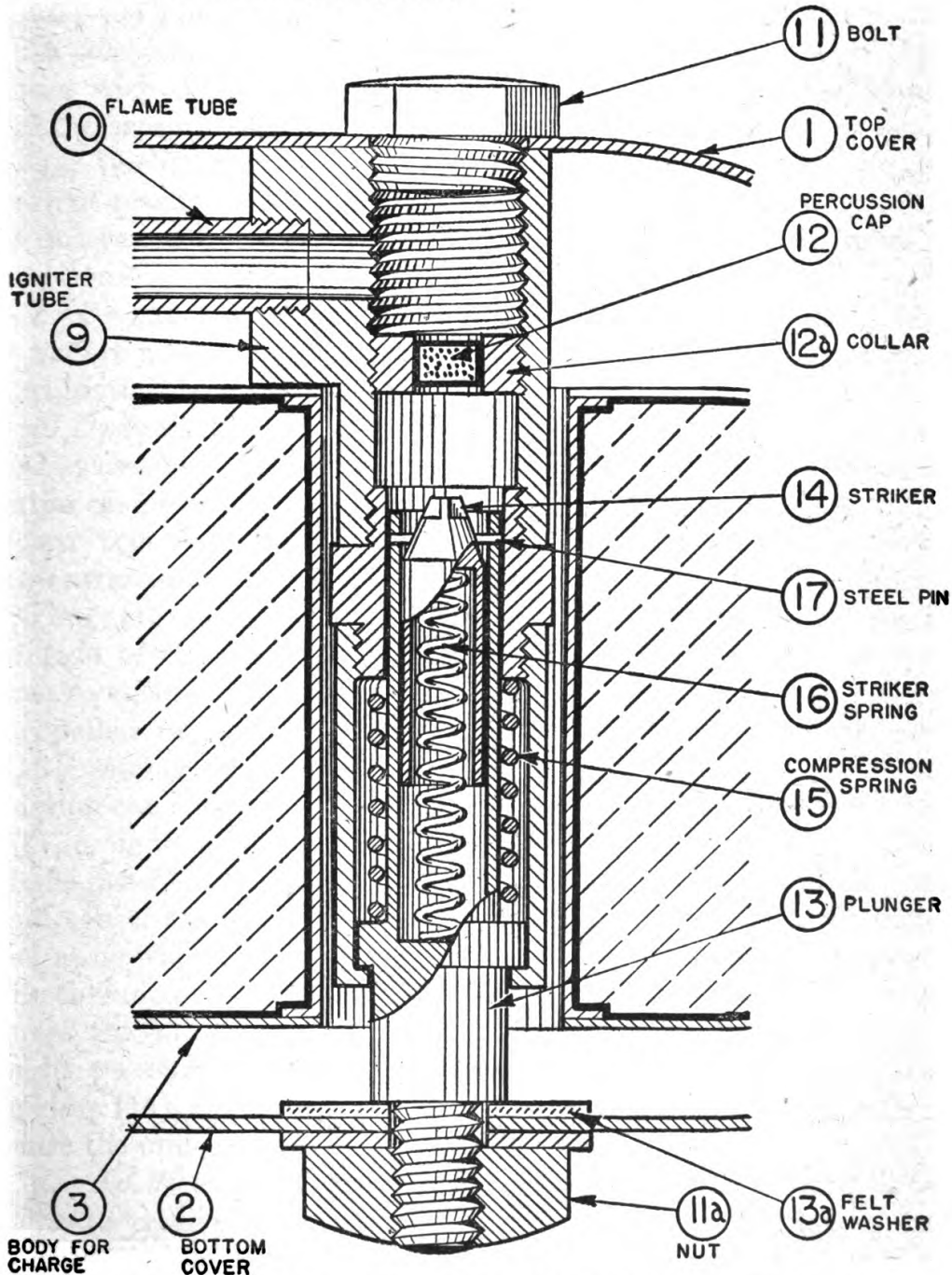

FIGURE 26.2.—Section through igniter for light antitank mine L. Pz.

(3) *Safety device* (fig. 26.1).—The L.Pz. mine has only one safety device. It is the safety screw (8) with an enlarged milled head which is threaded in the top of the chamber (7). The screw (8) is protected by a metal cap (18) which is fastened to the mine by two studs and bayonet catches (21). The head of the screw (8) has the word "SICHER" (safe) stamped on it with an arrow pointing in a clockwise direction. A white radial line (19) also appears on the top of the screw head. A white mark (20) appears on the top of the mine under the cap (18). When the screw head (8) is screwed up tightly in a clockwise direction and the white line (19) on the head (8) coincides with the white mark (20) on the mine, the beveled lower end of the screw will have closed the flash hole leading to the detonator (5). With the screw (8) in this position, the flame from the igniters cannot reach the detonator (5), and the mine is safe. The screw (8) is unscrewed to the position shown in the figure when the mine is laid and armed.

b. Employment.—The L.Pz. mine is an antitank mine. However, it may be adapted for use against personnel by removing the nuts (11a) and laying the mine on a hard even surface.

c. Operation.—The mine functions when a heavy vehicle or tank passes over it. The pressure from such a load is sufficient to crush the mine casing so that the top cover (1) and the igniter body (9) move down together. Since the plunger (13) remains stationary, the downward movement of the igniter body (9) serves to compress the spring (15) (fig. 26.2). When the enlarged recess of the upper section of the body (9) is opposite the steel pins (17), the pins are free to escape outward and thus release the striker (14) which is then propelled upward by pressure from the compressed striker spring (16), setting off the percussion cap (12). The flame from the percussion cap travels along the horizontal flame tube (10) to the chamber (7), or ignites a fuze in the tube (10) (see *a* (1) above). When the flame reaches the chamber (7), it passes down to the detonator (5) and causes the mine to explode. The mine operates as an antipersonnel mine when the nut (11a) is removed and the mine is supported on the threaded end of plunger (13). The weight of the mine will compress the plunger spring (15). In this condition a comparatively light pressure exerted on the cover (1) will further compress the spring (15) and result in the release of pins (17) which action will cause the mine to explode as described above.

d. To disarm.—There is no apparent receptacle built into this mine to receive a secondary firing device. The British report the construction of the mine is such that it is unlikely that any of the push firing devices could be replaced by a pull type firing device

with trip wires. However, improvised methods or a supplemental charge could be placed under the mine and connected to a release type igniter. Therefore, it is important that the area in the vicinity of mines of this type be carefully examined before neutralization is undertaken. The mine is first neutralized by turning the safety screw (8) clockwise, as indicated by the arrow, until it becomes tight and the white radial line (19) coincides with the white mark (20) on the mine. Since the mine might have been set for antipersonnel use and consequently be very sensitive, great care must be taken not to exert any pressure on the mine while screwing in the safety screw (8) to the safe position. Having neutralized the mine, proceed to disarm it in the following manner: lift the mine carefully clear of the ground, exercising great care not to tilt the mine and thus cause one of the igniters (9) to fire. Stand the mine on its edge. Remove the bolts (11) and unscrew each cap holder (12a) together with its percussion cap (12). From the figure, it is not clear how the holders (12a) can be engaged for removal but it may be possible that a tool engages a slot in the holder (12a). Then lay the mine upside down and, if the nuts (11a) are in position, remove them together with their steel washers. Remove the adhesive tape from the joint of the covers (1) and (2) and force off the cover (2) by inserting a screw driver or similar tool to pry it loose. Then remove the five felt washers (13a) from the plungers (13), and the three nuts (4a) from the bolts (4). Carefully remove the explosive body (3) from the cover (1). Finally, unscrew the retaining collar (6) and remove the detonator (5).

e. To arm.—The mine apparently comes fully assembled with the detonator (5) and the igniters in place. In this case, it is only necessary to remove the metal cap (18) and unscrew as far as possible the milled safety screw (8) by turning it counterclockwise. Replace the cap (18) to protect the screw (8). If it is desired to arm the mine for antipersonnel purposes, remove the nuts (11a) and carefully place the mine on a hard, even surface before unscrewing the safety screw (8).

[A. G. 300.7 (26 May 43).] (C 1, 30 Jul 43.)

45.2 (Added). T-5 antitank mine (fig. 26.3).—The T-5 antitank mine is primarily a light antitank mine. The British War Office states that it is thought this mine, like the Z. D. Z. 29 igniter which it employs, is now obsolete. There is no record of its having been employed in the present war.

a. Description.—The mine is cylindrical in shape, and is $2\frac{3}{4}$ inches in height and 10 inches in diameter. Its total weight is 13 pounds

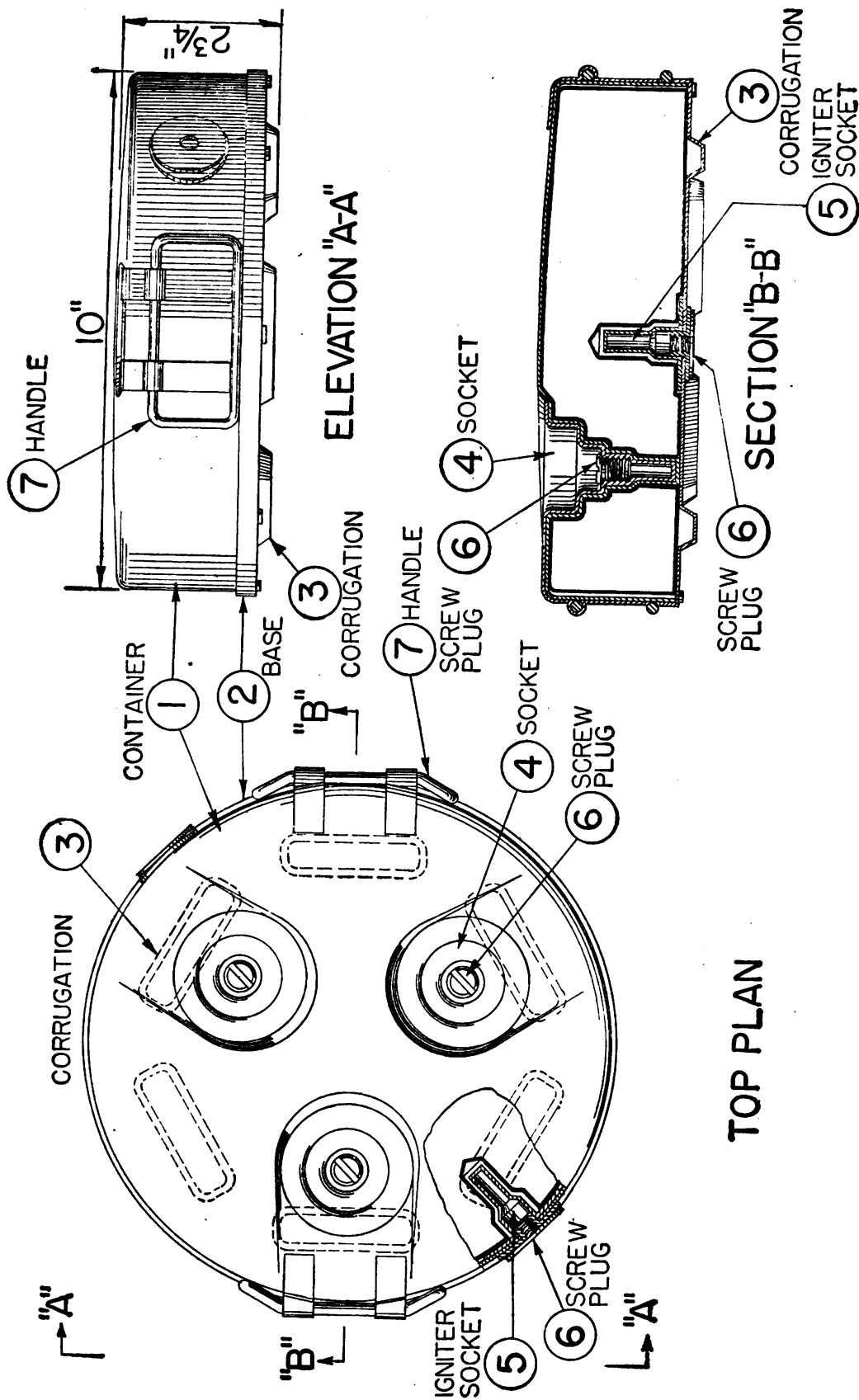

FIGURE 26-3.—T-5 Antitank mine.

and 3 ounces, of which 10 pounds is TNT filling. The mine consists of a zinc container (1) fitted to a zinc base (2). The base (2) is secured to the container (1) by means of a screwed rod (not shown in the drawing). The screwed rod projects either from the container or from the base and is secured by a circular nut to the other. Stamped in the base (2) are six corrugations (3) which serve to stiffen the base. Three screw-threaded sockets (4) in the top of the container (1) are provided to receive three combined igniters Z. D. Z. 29 which are described in paragraph 30. Three additional screw-threaded sockets (5), two in the side of the container (1) and one in the base (2), are provided to receive secondary pull igniters which act as actuating devices. All of the igniter sockets (4) and (5) are fitted with screw plugs (6) during transport. Two carrying handles (7) are provided on opposite sides of the container (1):

b. Employment.—This mine is primarily a light antitank mine. However, due to the variation of pressure for which the Z. D. Z. 29 igniter can be set, the mine may also be employed as an antipersonnel mine.

c. Operation.—The mine functions when pressure is applied by the passage over it of a tank or person. When the pressure for which the igniter was set is applied, the igniter functions and explodes the TNT. The mine may also operate by pull on the wire attached to either of the actuating igniters attached to the side of the container (1) or to the one attached to the base (2). The firing pressure varies from 99 pounds to 276 pounds. The mine is considered almost certainly blast proof.

d. To disarm the mine.—Since none of these mines has been encountered, it is not possible to issue set instructions for this procedure. However, the following principles should be followed: first neutralize the secondary igniters and then the main igniters. Unscrew the igniters and remove the detonators.

[A. G. 300.7 (26 May 43).] (C 1, 30 Jul 43.)

46. Heavy antitank mine (figs. 27 to 35, incl.).

* * * * *

c. Operation.—The mine is fired * * * under heavy tanks. A 100-pound pressure on the pedal will also fire the mine. Also, when the mine * * * hole in the road.

d. To disarm.—Owing to the * * * this igniter also. Examine the wire or web belt around the main charge box, and if there is no tension it may be cut. Remove the lid * * * used by vehicles.

* * * * *

[A. G. 300.7 (26 May 43).] (C 1, 30 Jul 43.)

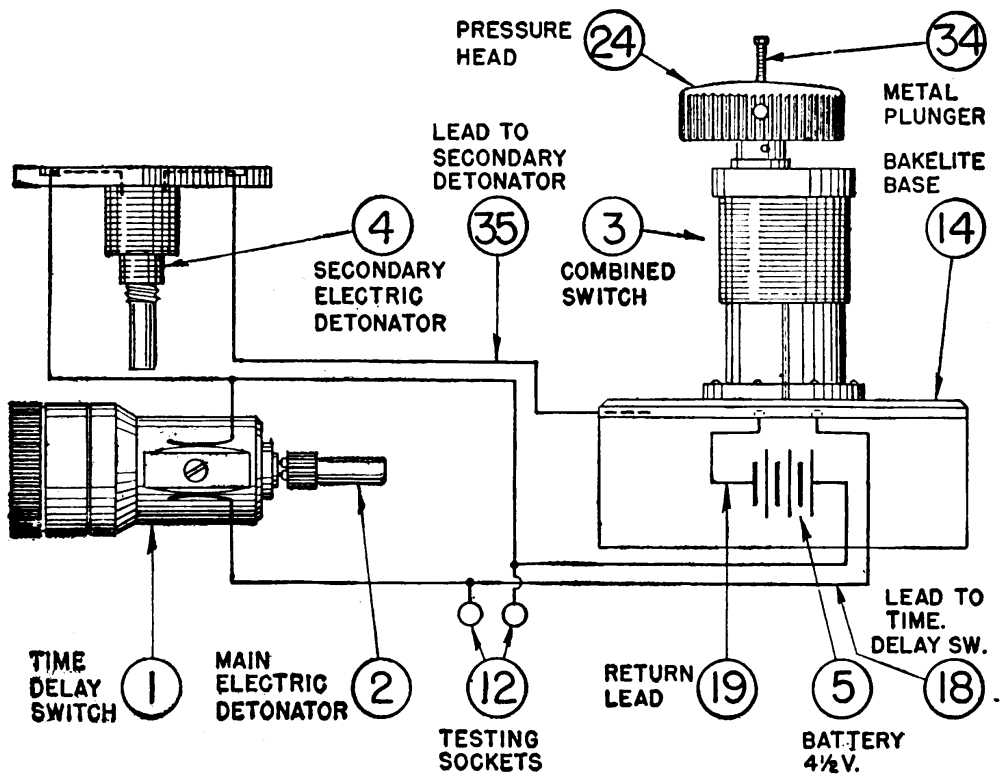
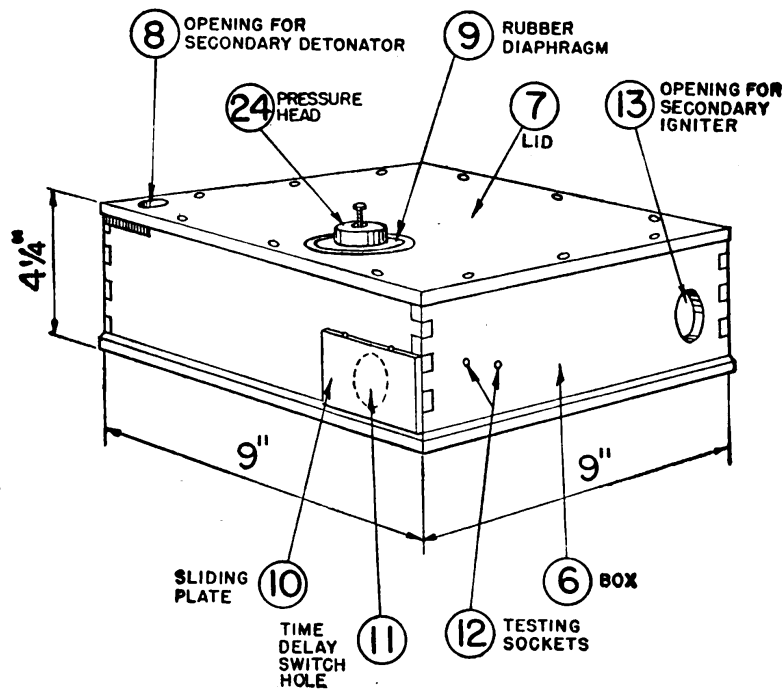

FIGURE 36.—Railway time-delay (electrically operated) mine.

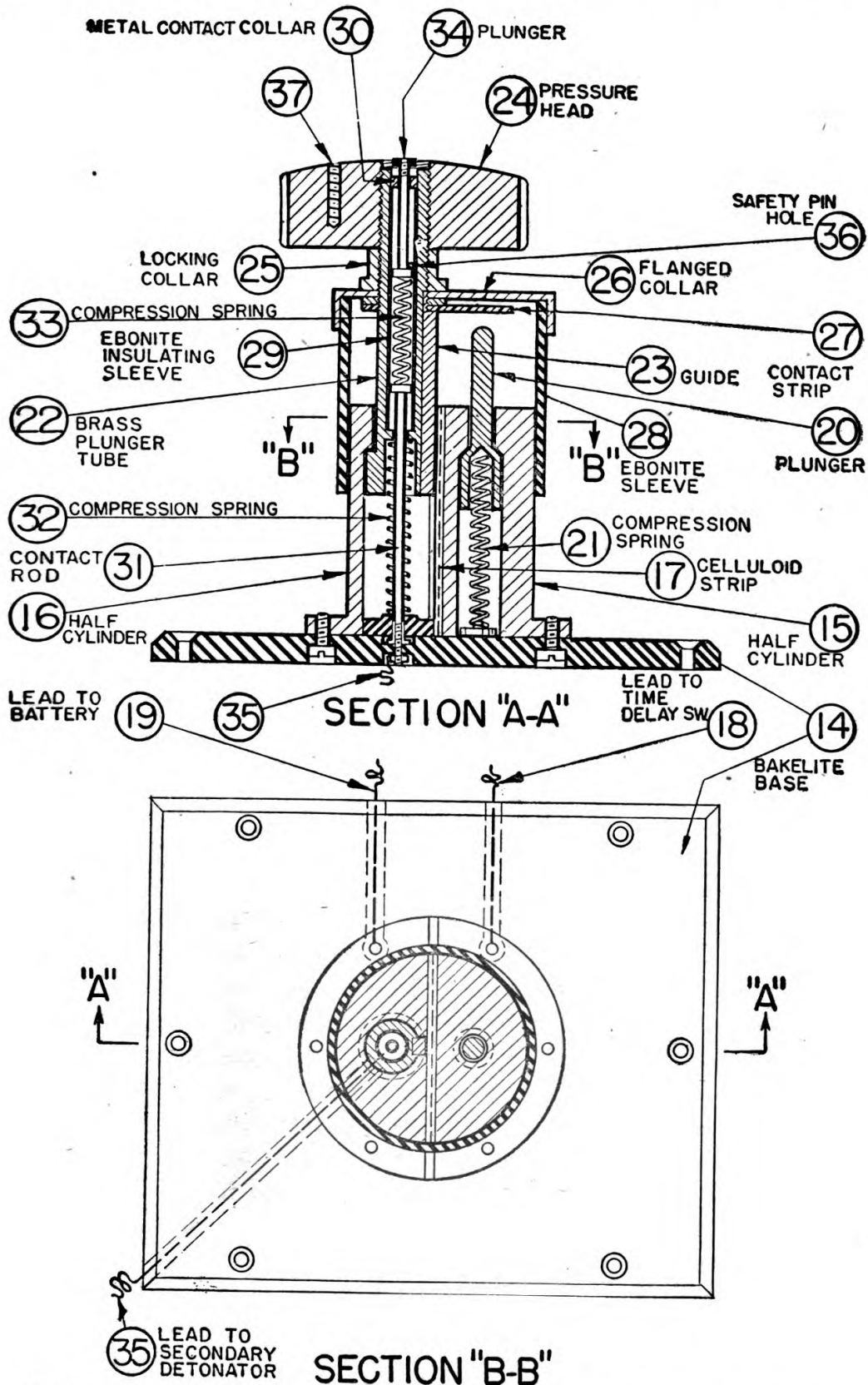

FIGURE 36.1.—Railway time-delay (electrically operated) mine, combined switch.

SECTION VII

GERMAN RAILWAY MINE

47. Railway time-delay (electrically-operated) mine (figs. 36 and 36.1).—This mine is electrically operated and is designed for the disruption of railway communications.

a. Description.—The railway mine * * * TNT in blocks. In addition to the charge, the mine is provided with a **time-delay switch assembly (1)**, a **main electric detonator (2)**, a **combined switch (3)**, a **secondary electric detonator (4)** and a **battery (5)**. Following is a detailed description of the principal parts:

(1) *Box.*—The box (6) is made of wood and is 9 inches square by 4 $\frac{1}{4}$ inches high. The lid (7) of the box is held down by screws and has two openings. One opening (8) gives access to a socket which provides a sliding contact with the circuit for the secondary electric detonator (4) and the other permits the pressure head (24) of the combined switch (3) to project above the box. The opening around the head (24) is sealed by a rubber diaphragm (9). On one side of the box is a sliding plate (10) covering a hole (11) through which the time-delay switch assembly (1) comes into sliding contact with the main circuit. Just around the * * * detonator or igniter.

(2) *Time-delay switch assembly.*—The time-delay switch assembly (1) is made up of a clock, a setting disk, and a switch and is assembled with the main electric detonator (2) as a unit. The setting disk * * * fire the mine. The time-delay switch assembly (1) is wired to the combined switch (3) and together they form the main circuit. The current for operating the circuit is supplied by a flat flashlight battery (5) which gives a voltage of approximately 4 $\frac{1}{2}$ volts and is housed in a small wooden box which is 2 $\frac{1}{2}$ by 2 $\frac{7}{8}$ by 1 inch deep.

(3) (Superseded.) *Combined switch* (fig. 36.1).—The combined switch (3) is a combination pressure and release switch. It consists of a bakelite baseplate (14) which is mounted by screws to the wooden box containing the battery (5). Two half-cylinder metal bodies (15) and (16) are each mounted onto the plate (14) by three screw bolts and are insulated from each other by a strip of celluloid (17). Half cylinder (15) is electrically connected by wire (18) to one pole of the battery (5) through the time-delay switch assembly (1) and the main detonator (2). Half cylinder (16) is electrically connected by wire (19) to the opposite pole of the battery. The connections are made through two of the studs fastening the half cylinders (15) and (16)

to the bakelite plate (14). Within the half cylinder (15) and in metallic contact with it is a plunger (20) with a compression spring (21). Within the half cylinder (16) and in metallic contact with it is a brass plunger tube (22) with a square brass guide (23). The pressure head (24) with a locking collar (25) are both screw mounted to the tube (22) which also has fastened to it, a brass flanged collar (26) and a fan-shaped contact strip (27). The flange of the collar (26) is fitted tightly to an ebonite sleeve (28) which slides over the half cylinders (15) and (16). Within the tube (22) is positioned an ebonite insulating liner (29) with a metal contact collar (30) at its upper end. The brass tube (22) acts as the plunger for the pressure head (24) and rides over a contact rod (31) which has an insulating ebonite sleeve. The rod (31) is rigidly supported by the bakelite plate (14). The pressure head (24) and the tube (22) are, normally, held in the upward position by a compression spring (32). Resting on the metal head of the rod (31) is a second compression spring (33) which supports the lower metallic head of a small metal plunger (34). This plunger is also fitted with an ebonite sleeve and has an ebonite nut screwed onto its upper end. The collar (30) acts as a guide for the plunger (34) and, when the plunger is freed to rise above the pressure head (24), as shown in elevation in figure 36, the metallic lower head of the plunger (34) comes into electrical contact with the collar (30). This contact completes the secondary firing circuit through the spring (33) and the rod (31), which is connected by a wire (35) to the secondary igniter (4). In the unarmed condition, a *nonmetallic* safety pin is inserted in the safety pin hole (36) in the collar (25) which passes over the lower metallic head of the plunger (34) and holds the plunger below the top surface of the pressure head (24). Three threaded sockets (37) are provided in the top surface of the pressure head (24) for a booby trap installation.

b. Employment.—This mine is * * * time has elapsed. The various methods of detonation possessed by this mine indicate that it may have a great number of uses. However, available information does not mention any other uses.

c. Operation (Superseded).—This mine is adapted for operation in the following ways:

(1) The clock mechanism in the time-delay switch assembly (1) is set for a specified delay by adjusting the graduated disk. The mine is then laid under a railroad tie so that the pressure head (24) just touches the under side of the tie with the plunger (34) held depressed by a nonmetallic safety pin in the safety pin hole (36). If necessary, the pressure head (24) may be unscrewed slightly to insure positive

contact with the under side of the tie. Remove the safety pin from the safety pin hole (36). At the expiration of the time-delay, the switch in the assembly (1) closes. Afterwards, upon the passage of a train along the tracks, the pressure head (24) is depressed and the plate (27) makes contact with the plunger (20). This contact closes the main electric circuit which fires the main detonator (2) and explodes the charge.

(2) The time-delay switch assembly (1) is set and the mine is layed as described in (1) above with one exception: the pressure head (24) is fully depressed so that the contact plate (27) makes contact with and depresses the plunger (20). At the expiration of the time-delay, the switch in the assembly (1) closes and completes the main firing circuit which fires the main detonator (2) and explodes the charge.

(3) The mine may also be fired inadvertently as follows: If the tie which contacts the pressure head (24) is lifted or the mine moved out from under it, the spring (33) forces the plunger (34) upward. Thus, the lower head of the plunger (34) comes in contact with the collar (30) and completes the secondary firing circuit which fires the secondary detonator (4) and explodes the charge. The mine may also be fired if a metallic pin is inserted in the safety pin hole (36) with the intention of holding down the plunger (34). This action creates contact between the collar (25) and the metallic lower head of the plunger (34) thus completing the secondary firing circuit. Another booby trap method of firing the mine is by means of a "booby trap transit cover" attached to the pressure head (24) by means of screws inserted in the threaded sockets (37). However, available information is not clear on this last method of firing.

d. To disarm.—When this mine is discovered in place, care must be taken not to move it. Disarm as follows: Remove any material which may be concealing the mine. Search for pull or release devices which may have been inserted in the opening (13). If such devices are present, neutralize them by placing a nail or safety pin in the safety pin hole and then cut the trip wire. Locate the sliding door (10) covering the time-delay switch assembly (1). Slide it open and pry out the time-delay switch assembly (1) and the attached detonator (2). A screw driver may be used for this purpose if necessary. Locate the secondary electric detonator (4) in the top of the mine at (8) and pry it out. If the detonator is not accessible, it may be necessary to hold the release plunger (34) down and turn the mine until the secondary detonator (4) is exposed. The mine is now disarmed and can be moved. During the process of dis-

arming, the following precautions should be observed: do not lift the mine until all detonators have been removed. *Do not insert a metal pin or nail in the safety pin hole (36)* while the secondary detonator (4) is still in the mine. Do not allow the release plunger (34) to rise while the secondary detonator (4) is still in the mine. Do not exert any pressure on the pressure head (24) while carrying out any of the above operations.

e. To arm.—When it is desired to use the mine against the enemy, it may be armed as follows: After making sure that the **time-delay switch assembly (1)** and the electric detonator (2) have been removed from the mine, depress the release plunger (34) and hold it in place by inserting a **nonmetallic pin** in the safety pin hole (36). Place the mine under a railroad tie or sleeper in such a way that the pressure head (24) bears on the under side of the tie but is not depressed by it. Remove the safety pin from the safety pin hole (36). Set the clock to close the switch in the **time-delay switch assembly (1)** at the desired time and insert the assembly (1) with the detonator (2) in the hole (11). Finally, insert the electric detonator (4) **in its socket through the hole (8)** and cover and camouflage the mine. A secondary pull igniter may also be inserted in the mine through the hole (13) to act as a booby trap and its safety pin should not be removed until the trip wires are laid.

f. Test.—The test for battery voltage may be made by inserting leads of a voltmeter in the test sockets (12) and pressing down on the pressure head (24) of the combined switch (3). When this test is made, the **time-delay switch assembly (1)** and the secondary electric detonator (4) must be removed from the mine.

g. Caution.—A metallic pin must not be inserted into the safety pin hole (36) unless the secondary electric detonator (4) has been removed.

48. Antipersonnel bounding mine (silent soldier) (figs. 37 and 38).—This mine is the standard German antipersonnel mine. It is known as the “S” mine (Schutzemine—protective mine) and is referred to as the “S” mine in all reports pertaining to it. It is designed * * * about 33 pounds.

* * * * *
b. Employment.—This mine is most * * * at 7-yard intervals. In installations found in and around abandoned airports, this mine has been found buried with the tops of the antennae just below ground level. They have been found around the perimeter of an airfield, set in ploughed furrows, approach roads,

hangars, vehicle pits, parking areas and among derelict airplanes and vehicles.

c. Operation.—The mine may be operated by pressure or by pull. If it is to be operated by pressure, a standard pressure igniter (24) (see fig. 38) type S. Mi. Z. 35 (see par. 29), is screwed into the top of the tube (7) (see fig. 37). It may also be operated by the E. S. Mi. Z. 40 Igniter. (See par. 32.3). If the mine is to be operated by a pull, a Y-connection (22) is screwed into the top of tube and two standard igniters of the type Z. Z. 35 (see par. 26) or Z. u. Z. Z. 35 (see par. 27) are screwed into the branches of the Y. In either case,
* * * and 200 yards.

* * * * *
[A. G. 300.7 (26 May 43).] (C 1, 30 Jul 43.)

48.1 (Added). “S” mine (pattern '42).—The 1942 pattern of the German “S” mine differs in the following respects from the old type described in paragraph 48 and shown in figure 37. The detonators placed in the tubes (8) are held in close contact with the compressed powder delays of the tubes (11) by means of spring loaded plungers, secured to the under side of the screw plugs (9). As a result of the spring loading of the detonators, the new pattern “S” mine should burst at a more uniform height above the ground. In addition, both containers (1) and (2) have been given a thin copper protective coat to prevent rust. For transport, the mines are carried three in a water-tight pressed metal carrying case, with carrying handle on top, instead of three in a wooden box.

[A. G. 300.7 (26 May 43).] (C 1, 30 Jul 43.)

49. General.—The German instructions * * * delay action firing. In North Africa, British 250-pound aerial bombs were found equipped with pull igniters and trip wires.

[A. G. 300.7 (26 May 43).] (C 1, 30 Jul 43.)

50. Improvised high-explosive shell antitank mine.—*a. Description* (Superseded).—The assembly of this mine which is also known as the Geschossmine, is similar to the Brettstuckmine (see par. 64). It is made up of two high-explosive shells which are placed on a plank and are wired to a pressure plank. Each shell has a D. Z. 35 pressure igniter screwed into an adapter which replaces the normal fuze of the shell. For this reason only those shells which can receive this adapter can be employed in this mine.

* * * * *
[A. G. 300.7 (26 May 43).] (C 1, 30 Jul 43.)

55. Schlüsselmine (key mine) (fig. 43).—*a. Description.*—The Schlüsselmine (key mine) * * * branch detonating cord. The

firing assembly is mounted on a "key" (3) which is the regular Tellermine tool or a similar support. In turn, the "key" (3) is supported on two stakes (4) adjacent to the base of a tree trunk. The firing assembly consists of a push and pull igniter (5) (combined igniter Z. D. Z. 29, described in par. 30), a detonator (6), and a pull wire (7). The pull wire * * * flexible safety key (10).

* * * * *

[A. G. 300.7 (26 May 43).] (C 1, 30 Jul 43.)

64. Brettstuckminen (board mines) (figs. 52 and 53).—The Brettstuckminen (board mines), also known as "one charge" mines, are improvised antipersonnel mines. They are operated * * * laying this mine.

* * * * *

b. Employment.—The mine shown in figure 52 is sensitive to sympathetic detonation and is, therefore, used for random or isolated mine laying. It is laid in a circular hole similar to that used for Tellermines (see fig. 22) except that the hole is 4 inches deeper. The mine shown in figure 53 is used in regular minefields and is laid in a shallower trench, shaped as shown. The sill board * * * shown in figure 53.

* * * * *

[A. G. 300.7 (26 May 43).] (C 1, 30 Jul 43.)

65. Druckbrettmine (pressure board mine) (fig. 54).—The Druckbrettmine (pressure board mine), also referred to as the "twin charge" mine, is similar to the Brettstuckmine. The mine is * * * an antilifting device.

* * * * *

c. Operation.—Pressure on the board * * * explode the charges. The pressure required at the center of the board (3) to fire the mine is 265 pounds. The pressure required directly over the charges (1) is 132 pounds.

* * * * *

[A. G. 300.7 (26 May 43).] (C 1, 30 Jul 43.)

65.1 (Added). 25 kg. aerial bomb mine.—This mine was found installed at Berka 3 Airfield.

a. Description.—This improved mine is made up of a 25 kg. aerial bomb connected to a gun cotton charge to which is attached a pressure igniter. A 10-inch board is laid on the pressure head of the igniter and is buried just below the surface of the ground.

b. Employment.—These mines were laid in a straight line down the runway at 25-yard intervals.

c. Operation: When pressure is applied to the pressure igniter, the igniter fires the gun cotton charge which in turn fires the aerial bomb.

[A. G. 300.7 (26 May 43).] (C 1, 30 Jul 43.)

65.2 (Added). Improvised wooden box mines.—Wooden mines of all sizes and types of construction have been encountered in the field. They all contained a charge and a pressure igniter. Their lids were either loosely attached to the box by wire or were hinged. In all cases the lids rested on the head of the pressure igniter and consequently when pressure was exerted on the lid the mines exploded. Reports from Norwegian authorities state that land mines are now being manufactured in Norway with wooden cases of $\frac{3}{8}$ inch fir approximately 8 inches square and 2 inches high. It is believed that the inside surfaces are impregnated to receive a charge of "Trinol." The igniter or fuze is encased in zinc and is inserted in a bed of compressed trinol. The mine operates by pressure and is intended to be employed in coastal defenses.

[A. G. 300.7 (26 May 43).] (C 1, 30 Jul 43.)

68. German employment of booby traps.

* * * * *

c. Traps encountered in the field.—Traps employing pull * * * added antilifting devices. The following traps have also been found: mortar bombs provided with fuze sockets and fitted with igniters Type S. Mi. Z. 35; egg and stick grenades with pull igniters; 4-gallon gasoline cans, painted khaki, and containing a booby trap; and traps installed in wells and cisterns. One such installation consisted of a 40-pound charge and a Tellermine connected with a pull igniter and a cord to the man-hole cover. Where booby traps were located under pickets, the pickets were normally dug in while others were knocked in. A report has been received recently that the enemy is also using a booby trap consisting of a hand grenade inside a water bottle. Explosion occurs when the cork is withdrawn.

[A. G. 300.7 (26 May 43).] (C 1, 30 Jul 43.)

69. Marking.—Booby traps are often marked with distinguishing signs, such as a swastika or skull and crossbones, left unintentionally by the Germans due to a rapid evacuation.

[A. G. 300.7 (26 May 43).] (C 1, 30 Jul 43.)

70. General.—The principles which * * * used for road blocks. In several places, a single strand of wire has been found fastened to long pickets and marked with notice boards (ACHTUNG MINE—ATTENTION MINE—ATTENTION

MINES). This wire does not protect live mine fields; however, it is fitted with booby traps. Mine fields are placed at one or the other end of the wire in prolongation of it. Dummy mine fields have been found completely wired in. Tins were sunk in the ground, to some of which booby traps were attached. Gaps between these dummy mine fields were invariably found mined with live mines. This type of installation may be recognized by the absence of tire tracks through the gaps. However, this is not always true, as the Germans may use spare tires to reproduce tracks through the gap. Tellermines have also been found laid in patterns with intervals of 10 to 20 yards and rows from 10 to 20 yards apart on abandoned airfield runways. They were also found irregularly laid interspersed with "S" mines (antipersonnel bounding mines) which are laid 15 yards apart. Areas liable to heavy aircraft traffic were found to be heavily mined.

[A. G. 300.7 (26 May 43).] (C 1, 30 Jul 43.)

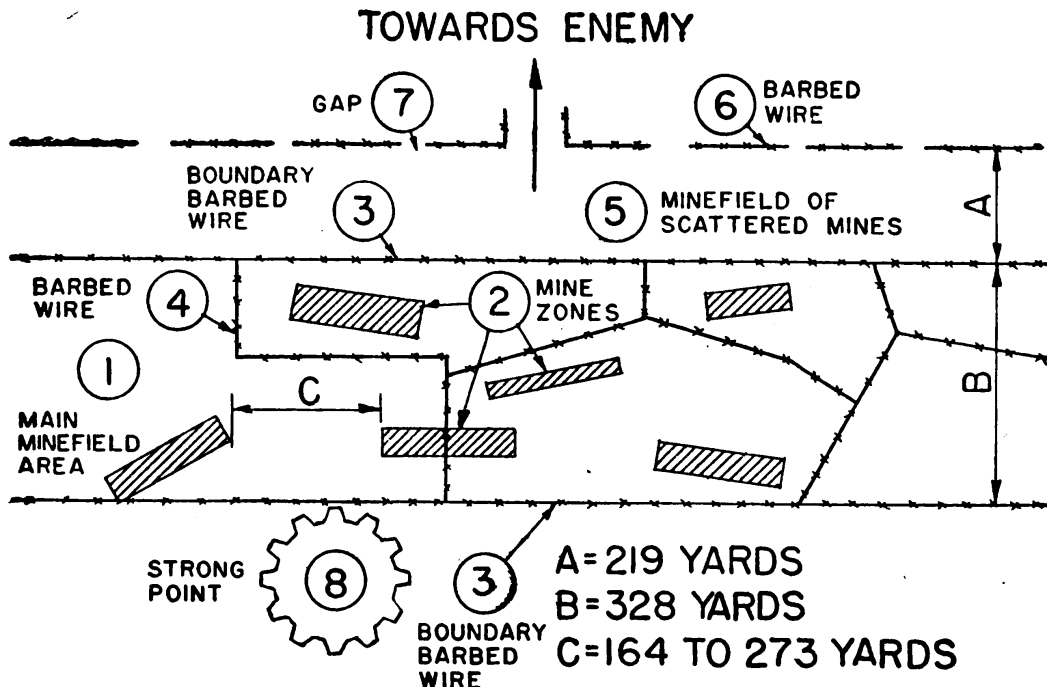

FIGURE 56.1.—German-Italian mine field lay-out.

71. Mine field lay-out.

* * * * *

b. Tellermine mine field patterns.—The measurements which * * * 980 yards long. Tellermines may also be found laid at very irregular spacing, but always to some definite plan. They may be found laid across tracks marked by small stone cairns, or

laid along tracks. In this case, the mines are usually marked by small stone cairns at either end of the track mined. An unsigned and * * * the following patterns:

* * * * *

(2) *Deliberate mine field*.—Lay-out for a * * * extensive mine field lay-out (see fig. 59). In a report dated September 1942, from North Africa, it was stated that a variation in the pacing of the deliberate mine field shown in figure 56 was found. The variation consisted of the horizontal and vertical coordinates being six paces and the minimum spacing between mines being seven paces. When open spacing was employed, the above dimensions were doubled. Figure 56.1 shows a German-Italian plan of a mine field in which the deliberate mine field pattern was used. The main mine field area (1) with mine zones (2) laid in patterns are bordered in the front and rear with barbed wire (3) and with other barbed wire (4) running irregularly through the mine field for the purpose of deception. In front of the main mine field (1) is a mine field (5) of scattered mines marked in front with a broken line of barbed wire (6). The gaps (7) are intended for deception. A strong point (8) is located to the rear of the main mine field.

* * * * *

e. (Added.) *Mine fields in desert terrain*.—The following additional information on the pattern, spacing, and tactical setting of mine fields has been obtained from prisoners of war in the North African theater of operations.

(1) *Patterns*.—Patterns may vary considerably and are decided upon by the officer in charge of a particular task. Among those most frequently found are the following.

(a) *Regular pattern*.—Regular patterns are most commonly used. Mines in a row are equally spaced, with equally distant rows, and with the mines of one row equally spaced between the mine of the previous row. A variation in this method is to vary the distance between rows.

(b) *Regular pattern offset*.—The regular pattern offset is similar to the German deliberate mine field pattern shown in figure 56. Once a few mines have been located, the pattern soon becomes apparent and mines will be found where expected.

(c) *Random mines*.—Unmarked mines, scattered at random, may be found in front of most regular mine fields, and particularly in front of gaps.

(2) *Spacing*.—The average spacing between individual mines in a row has been found to be 6 yards. It has never been less than 3 yards,

and seldom greater than 10 yards, except in scattered fields. The usual distance between rows are 5 and 10 yards.

(a) *Shallow mine fields*.—Shallow mine fields usually consist of from two to four rows of mines.

(b) *Deep mine fields*.—Deep mine fields usually consist of several belts of mines with considerable distances between belts. Each belt may have as many as eight rows of mines, extending 200 yards in depth. Normally, German mine fields are the “deep” rather than the “shallow” variety.

(3) *Tactical siting*.—Mine fields are usually located, according to one report, 215 to 325 yards in front of the main line of resistance. Another report states that the farthest distance encountered was 1,080 yards. Listening posts were discovered by patrols 100 to 150 yards behind a mine field. The mine fields are guarded at night by antilift- ing patrols and by day they are covered by small-arms fire.

(4) *Gaps*.—Gaps through mine fields have been reported to be 7 to 10 yards wide. They are usually closed by means of two or three rows of Tellermines with boards connecting the tops of the mines to insure detonation of the mines if a vehicle attempts to pass through the gap. Normally, these gaps are kept closed. Gaps are sometimes protected by unmarked groups of Tellermines scattered in front of the gap.

f. (Added.) *Recent information on mine field lay-outs*—Two mine fields at Henieimat were found situated 2,000 yards apart. Each mine field consisted of from ten to twelve rows of mines from 600 to 800 yards in depth. Scattered mines marked by two pickets were laid in advance of the fields. The rear four rows of mines in each field were Tellermines in one field and French light antitank mines in the other. The front rows in both fields consisted of antipersonnel bounding mines (“S” mines).

[A. G. 300.7 (26 May 43).] (C 1, 30 Jul 43.)

73. Summary of German mine field practice.

* * * * *

e. (Added.) *Marking of mine fields*.—In 1942, a German Order issued by the “90 Light Division” stated that the existing methods of marking of mine fields was inadequate. Mine fields were to be marked, either by a strong wire fence 1 meter high (39 inches) or stone walls 40 centimeters (16 inches) high. However, substitute materials such as barrels, concertina wire, tin cans, or derelict vehicles might be used. In a report from Agedabia, the perimeter mine field, without markings, was located 20 yards behind the perimeter wire. Mines, laid on roads or tracks in North Africa, were usually found installed close

to some easily identifiable landmark, such as a kilostone, track junction, or a small stone cairn. Mine fields and road blocks were also found marked by a 40-gallon oil drum, usually with a patch of red paint

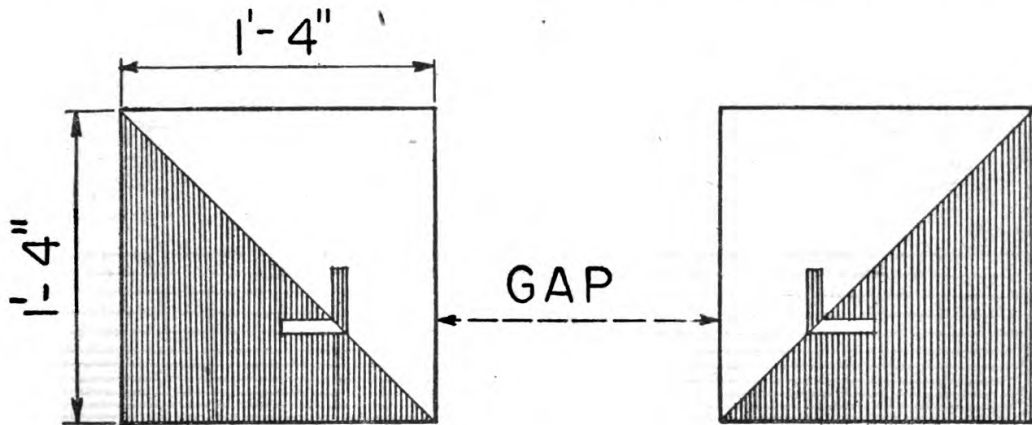

FIGURE 62.1.—Mine field gap signboards.

and holes in the top which marked routes past the mine fields. In May, 1942, an Order of the German ("15 Armored Division") described mine field gap identifying signboards (see fig. 62.1) in red and white which were to be mounted on posts 3 feet 6 inches to 5 feet high. In the northern sector of the El Alamein line, mine field gaps were found which were marked by 1-inch long luminous tubes placed on top of the mines. They marked a route for patrols and were visible 3 yards away. Gaps have been reported to be 7 to 10 yards wide. Often the front edge of mine fields is not marked, the rear edge being usually marked by some form of fence, such as a trip wire on short pickets. Occasionally, the rear edge of a mine field has been found unmarked. A common marking for mine fields is a single row of concertina wire along the center of the mine field and parallel to the rows of mines. In a large mine field there may be several unmarked rows of mines along the front, then a row of concertina wire, more rows of mines, then another row of concertina wire, and so on, with a row of concertina wire marking the rear edge of the mine field. Only one case has been reported of continuous wire running irregularly within a mine field.

f. (Added.) Enemy mine detection.—The Germans have been using a turned ferrous dumbbell cut into halves, which, when buried in a mine field, are intended to affect mine detectors (see fig. 62.1). It

appears that these dumbbells were manufactured originally for use either as a tank track roller or as a manual conveyor roller.

[A. G. 300.7 (26 May 43).] (C 1, 30 Jul 43.)

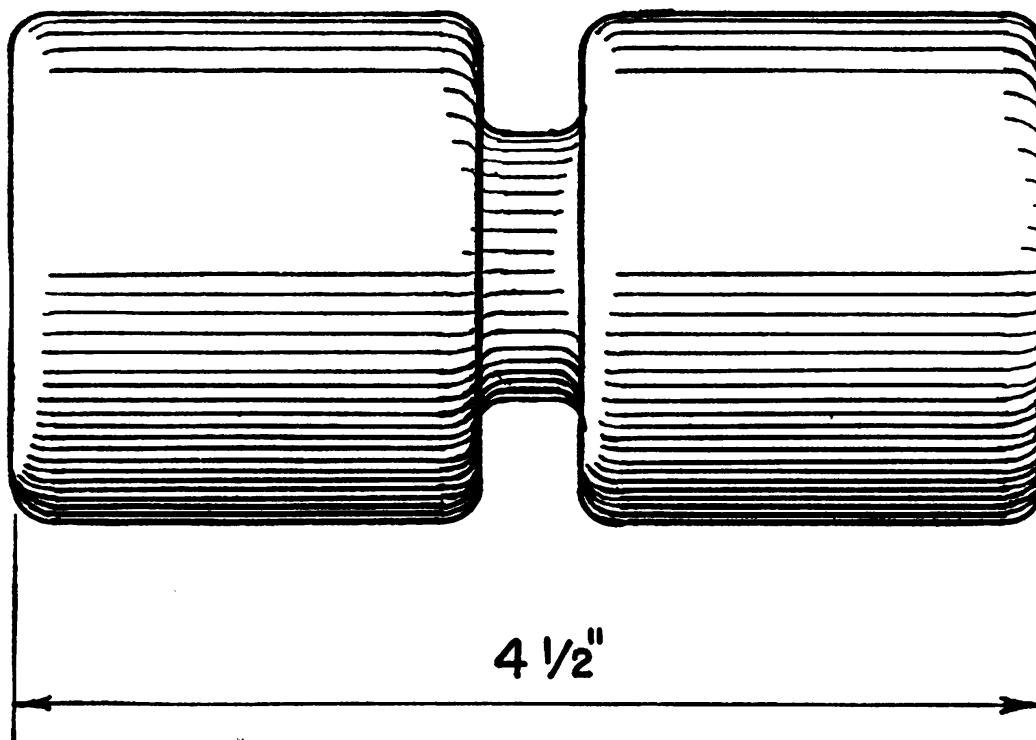

FIGURE 62.2.—Dumbbell used for delaying mine detection.

CHAPTER 3

ITALIAN LAND MINES AND DEVICES

74. General.

* * * * *

a. Unlike the German practice of using standard igniters, the Italians normally use a special igniter to fit the individual mine. However, two types of igniters have been encountered recently which may be considered as standard and are described in subsequent paragraphs.

* * * * *

[A. G. 300.7 (26 May 43).] (C 1, 30 Jul 43.)

75.1 (Added). Friction igniters **Miccia DA. 40** and **DA. 60** (fig. 62.3 (A)).—These Italian igniters are similar in every respect except in size and the time delay of the safety fuze which they employ. The DA. 40 igniter is $3\frac{3}{4}$ inches long and has a time delay of 10 seconds. The DA. 60 igniter is $4\frac{1}{2}$ inches long and has a time delay of 15 seconds.

a. Description.—The igniter consists of an aluminum tube (1), approximately $\frac{1}{4}$ inch in diameter. The open end of the tube (1) contains a small block of match composition (2) through which passes a length of galvanized iron wire (3) and is sealed with a plastic (4). The closed end of the tube (1) contains a detonator filling (5) with a primer (6) and a priming pellet (7) which receives the flash from the safety fuze (8). The fuze (8) is crimped in place at (9) while the igniter is held firmly in the charge by means of the raised flange (10).

b. Employment.—As yet, no information has been received on the employment of this igniter.

c. Operation.—A sharp pull on the wire (3) ignites the match composition (2) and, in turn, the fuze (8), the pellet (7), the primer (6) and the detonator filling (5) which explodes the charge in which the igniter is placed.

[A. G. 300.7 (26 May 43).] (C 1, 30 Jul 43.)

75.2 (Added). Time-delay igniter (fig. 62.3 (B)).—*a. Description.*—This igniter consists of a galvanized mild steel tubular body (1) which houses a striker assembly. This assembly is made up of a galvanized mild steel striker tube (2) which is threaded externally at both ends. One end of the striker tube (2) has a fitted striker pin (3) and a screwed flange (4) which restrains the spring (5). The other end of the striker tube (2) projects through the body (1) and is provided with a milled nut (6). Rotation of the nut (6) retracts the striker tube (2) and compresses the spring (5) until the shoulder of the striker (2) contacts the shoulder of the body (1). The striker is prevented from turning by a setscrew (7) riding in a groove (8). When the nut cannot be tightened further, a hole through the striker tube (2) coincides with a hole in the body (1) thus permitting insertion of a lead shear pin (9), $\frac{5}{64}$ inch in diameter. At the other end of the body (1) is screwed an aluminum adapter (10) which is threaded externally for insertion into the charge and has an internal groove into which is pressed a steel washer (11). The adapter (10) has a slot (12) through which is slipped in place a detonator (13) with a flanged percussion cap (14). The adapter (10) is unscrewed sufficiently to permit the flange of the cap (14) to be slipped in and is then screwed tight.

b. Employment.—As yet, no information has been received on the employment of this igniter.

c. Operation.—The igniter operates after the milled nut (6) is unscrewed, thus leaving the lead shear pin (9) to retain the striker tube (2) against the compression of the spring (5). Under the pressure of the spring (5) the shear pin (9) eventually fails, allowing the striker

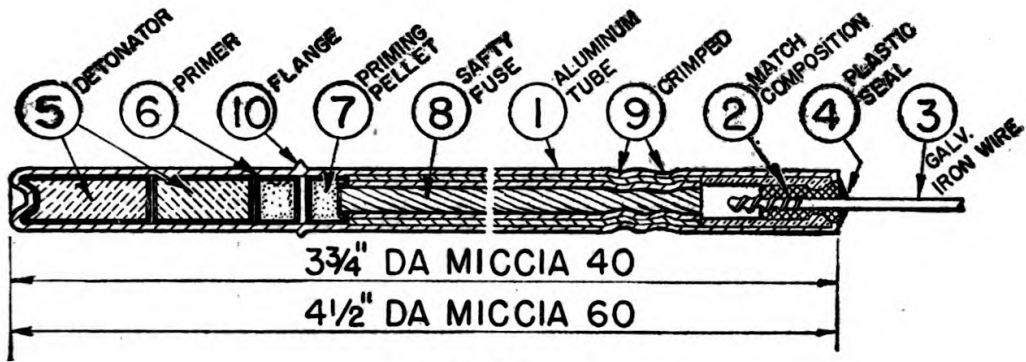

(A)

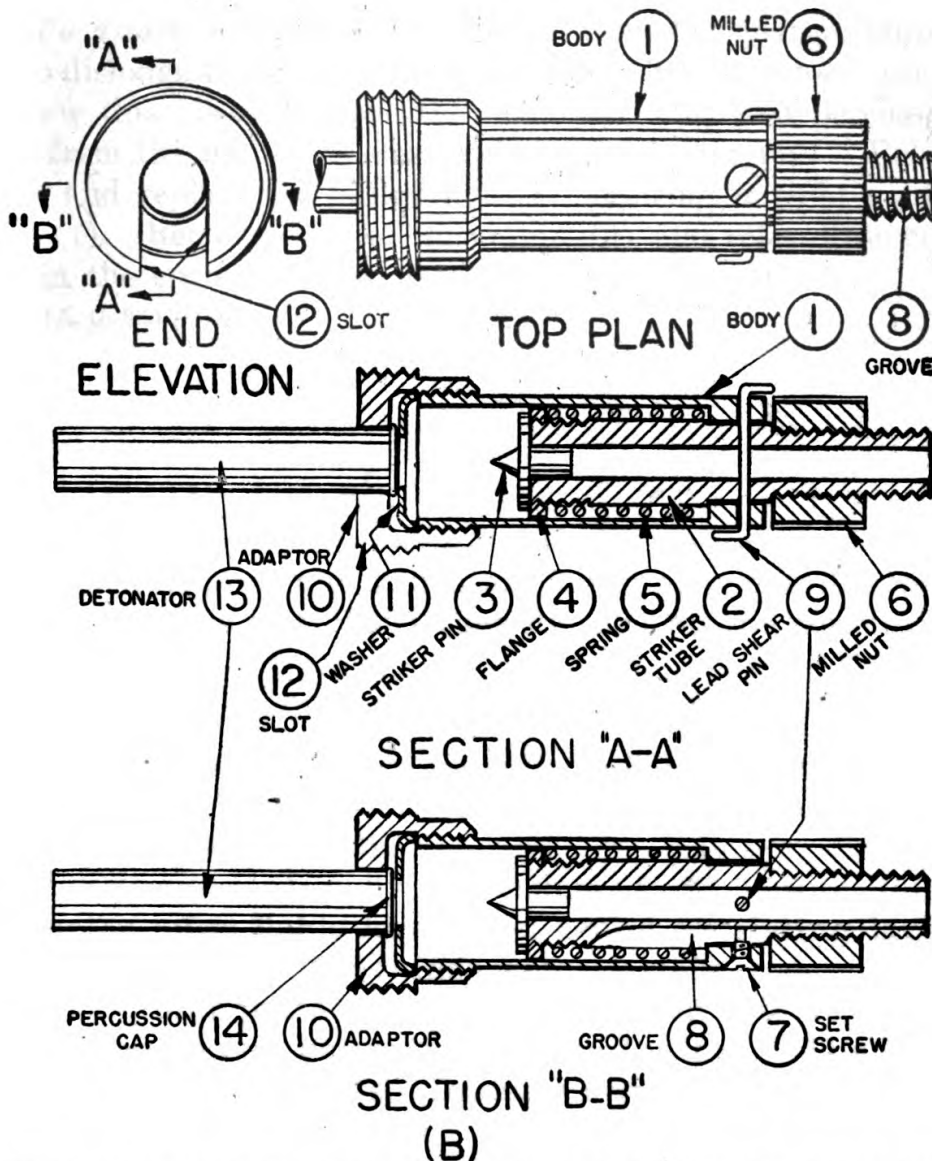

(B)

FIGURE 62.3.—Friction igniters miccia DA. 40 and DA. 60 and time-delay igniter.

pin (3) to fire the cap (14) and detonator (13). Tests made of four identical specimens gave the following time delays:

<i>Specimen</i>	<i>Time delay</i>
1-----	7½ min.
2-----	7 hrs. 16 min.
3-----	25 hrs. 45 min.
4-----	26 hrs. 7 min.

The discrepancy in these results may be due to possible tampering with the igniters before testing.

d. To neutralize.—Grip the striker tube (2) against the end surface of the body (1) with the cutting edges of a pair of wire-cutting pliers and wire the plier jaws in position.

e. To disarm.—Unscrew the igniter from the charge, taking care not to dislodge the pliers. If the adapter (10) remains in the charge unscrew this also. Remove the detonator (13) and percussion cap (14) from the igniter by unscrewing the adapter (10). Release the pliers and replace the milled nut (6) screwing it tight against the body (1). Remove the lead shear pin (9) and release the compression in the spring (5) by unscrewing the nut (6).

[A. G. 300.7 (26 May 43).] (C 1, 30 Jul 43.)

76. Type V3 (figs. 63 and 64).

* * * * *

a. Description.

* * * * *

(3) *Pressure-operated releases.*—Each release consists * * * striker holding pin. The minimum firing pressure obtainable by unscrewing the nuts (32) (see fig. 63) on the screws (29) is 22 pounds.

FIGURE 63.—Antitank mine, type V3.

(4) *Pressure control shear pin device.*—This device consists * * * that of tanks. The British state that these shear pins offer a resistance of 264 pounds.

b. Employment.—Usually, the mines * * * with this mine. Perimeter mine fields have been found consisting largely of Italian V3 mines. The mines were scarcely covered, and were laid in regular patterns of two rows from 4 to 10 feet apart, and spaced 10 feet between individual mines. The V3 mines were very easy to locate. Dummy mine fields formed part of these perimeter mine fields.

* * * * *

[A. G. 300.7 (26 May 43).] (C 1, 30 Jul 43.)

77. Type B-2 (figs. 65 and 66).

* * * * *

a. Description.

* * * * *

(2) *Igniter and actuating devices.*—The igniter is * * * retaining collar (16). The other end of the body (13) has a bored and machined hole (17) which receives the double-ended detonator and the cordtex (6), which is secured by a knurled screw collar (18). The igniter body * * * shears the wire.

* * * * *

[A. G. 300.7 (26 May 43).] (C 1, 30 Jul 43.)

80. Type 9, pressure operated (figs. 70 and 71).—

* * * * *

a. Description.—The mine (fig. 70) is * * * of the mine. The explosive (3) in the box consists of eight blocks of TNT, weighing approximately 9 pounds, placed so as to be in contact with the detonators (6). Each of the * * * the safety strip.

* * * * *

[A. G. 300.7 (26 May 43).] (C 1, 30 Jul 43.)

82. Type D (fig. 73).—This antitank mine * * * used in the Teller mine. The mine is waterproof.

* * * * *

[A. G. 300.7 (26 May 43).] (C 1, 30 Jul 43.)

86. Pressure mine with grenade exploder (fig. 78).—

* * * * *

b. Employment.—This mine is usually employed inside a wooden box with a loose lid.

* * * * *

d. To disarm.—To disarm the mine, first remove the lid of the wooden box carefully. It can be readily * * * a neutralized condition. To disarm the mine completely, remove the cover (3) and withdraw the igniter assembly.

* * * * *

[A. G. 300.7 (26 May 43).] (C 1, 30 Jul 43.)

87. Circular variable pressure mine (figs. 79 and 80).—This mine was first encountered in the Middle East during the enemy's attack on the Alamein defenses in the first week of September, 1942. It was originally described in captured Italian documents and was therefore considered to be an Italian mine. However, according to the latest British reports this mine is definitely of Hungarian origin but manufactured in Czechoslovakia. It is

somewhat similar to the German Tellermine (see par. 44) and may be operated either by pressure or pull.

a. Description.

* * * * *

(2) *Igniter*.—The igniter (fig. 80) * * * a detonator (27). The letters N, K, and H, on the igniter, are the initial letters for the Hungarian words, “heavy”, “light”, and “pull” respectively. A detailed drawing in an Italian document shows these letters changed to their Italian equivalents.

* * * * *

[A. G. 300.7 (26 May 43).] (C 1, 30 Jul 43.)

88. Land mine, railway type (old pattern) (fig. 81).—

* * * * *

FIGURE 81.—Land mine, railway type (old pattern).

88.1 (Added). Railway mine (new pattern) (fig. 81.1).—According to the latest British reports, one example of this mine has so far been encountered. The mine exploded during removal and consequently there are no further details than those given below.

a. Description.—The body of the mine appears to be made of two rectangular parts (1) and (2) with a circular pressure plate (3) on top. Part (1) appears to be secured to part (2) by steel springs, one on each side. A detonator (4) is inserted in a hole in part (1) with a piece of instantaneous fuze attached. A bakelite knob (5) is mounted on one side of the lower part (2). The mine is mounted on a wooden baseplate (6) provided at each end with leather straps (not shown) for carrying purposes.

b. Remarks.—The detonator (4) is believed to be a secondary means of firing the mine, while the bakelite knob (5) is probably coupled to some form of time-delay mechanism.

[A. G. 300.7 (26 May 43).] (C 1, 30 Jul 43.)

89. Type B-4 (figs. 82 and 83).—

* * * * *

a. Description.—The mine has the appearance of a sheet metal canister. It is 2¾ inches in diameter, 5⅛ inches high and weighs 3 pounds when charged. The mine proper * * * in detail as follows:

* * * * *

b. Employment.—This mine is generally * * * about 5 yards. In antipersonnel mine fields, these mines are used in combination with a few German antipersonnel bounding mines (silent soldier) (see fig. 37). The mines are laid 7 to 10 yards apart

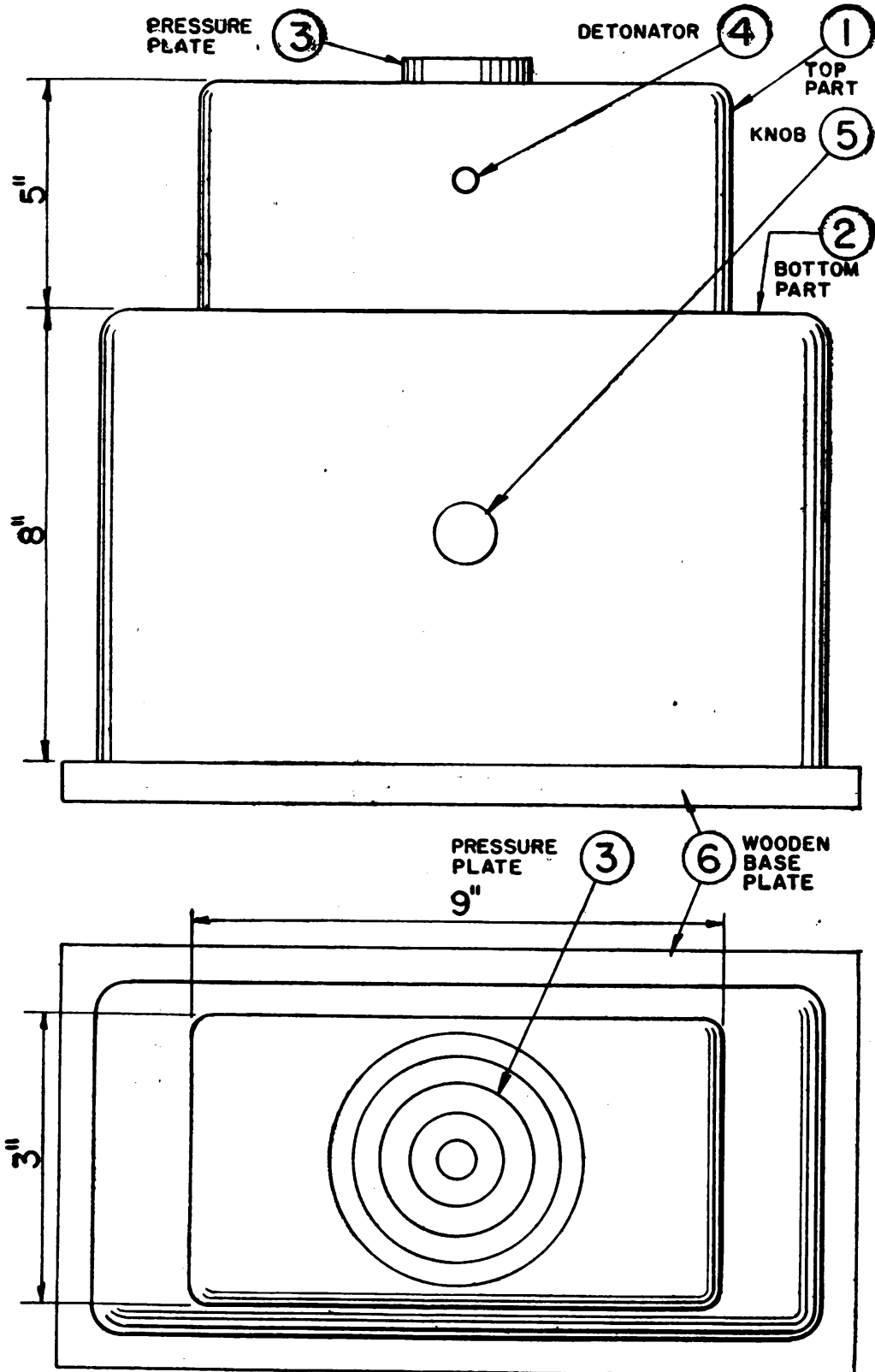

FIGURE 81.1.—Railway mine (new pattern).

and are connected with trip wires to wooden pegs set between them.

* * * * *

[A. G. 300.7 (26 May 43).] (C 1, 30 Jul 43.)

90. Type 9, improvised, tension-operated (figs. 84 and 85).—

* * * * *

e. To arm.—To arm the mine * * * in the slot. Run out the trip wires (18) and (19) through the sides of the box and fasten the far ends so that a slight tension is induced in the wires. Remove the striker * * * access opening (17).

91.1 (Added). Antipersonnel mine, type V5 (fig. 87.1).—This mine is in many respects similar to the Italian antitank mine, type V3 (originally designated as type N-5) but is designed as an anti-personnel mine. However, by increasing the firing pressure required, it can be made antitank in effect.

a. Description.—The type V5 mine is made of sheet metal steel, painted dark green, and consists of a rectangular box (1) which contains a long tube (2) to the ends of which are fitted two igniter assemblies. The mine is approximately 3 feet 10 inches long, 2½ inches high, and weights 11¾ pounds. The tube (2) contains a charge (3) which consists of nine cylindrical blocks of high explosive weighing a total of 2 pounds. Each end of the tube (2) is fitted with a metal sleeve (4) which contains an igniter assembly which is fixed to the sleeve (4) by means of a setscrew (5). Each sleeve (4) rests on a pressure spring (6) surrounding an actuating bolt (7) secured to the bottom of the box (1) by a pressure adjusting nut (8) and a lock nut (9). Each igniter assembly is made up of a metal body (10) which houses a striker mechanism and a percussion cap holder (11) inserted into an opening (12), and held in place by a retaining spring similar to the one used in the V3 (N-5) mine. The striker mechanism consists of a striker (13) which is held in the cocked position by a compression spring (14) and a sear (15). The sear (15) is held in position by a leaf spring (16), one end of which is fastened to the body (10) with a screw. The striker (13) is cocked by pulling outward the grip (17) until the head of the striker (13) is engaged by the sear (15). After the striker is cocked, the grip (17) is returned to its initial position and a safety pin is inserted in the safety pin hole (18). In the opening (19) of the body (10) is fitted the open end of a detonator which is inserted in a prepared hole in the main charge (3). The firing assembly is made operative by inserting a brass actuating pin (20) through slots (21), in the sleeve (4), over the splayed end of a U-shaped clip

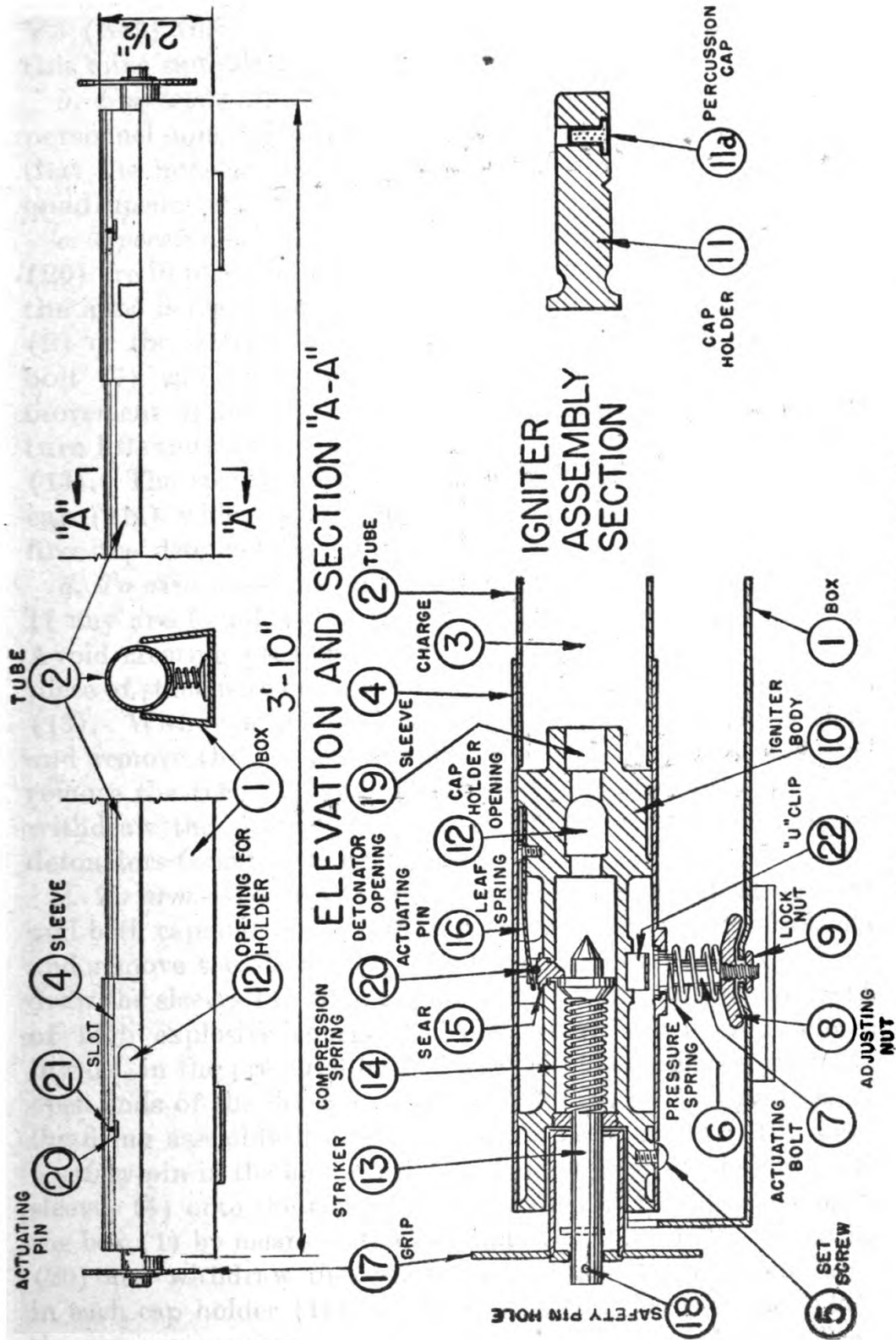

FIGURE 87.1.—Antipersonnel mine, type V5.

(22) and through the sear (15). Unlike the antitank mine type V3 (N-5) there is no provision for inserting a shear pin to render this mine suitable for antitank use only.

b. Employment.—This mine is employed primarily as an anti-personnel mine. However, it is stated in a captured Italian document that the mine is also employed against light vehicles, motorcycles, quadrupeds, and troops.

c. Operator.—When the strikers (13) are cocked, the actuating pins (20) are in place and the safety pins are removed from the holes (18) the mine is ready for operation. Pressure applied to either the tube (2) or the sleeve (4) will compress the spring (6), whereupon the bolt (7) will push upward the U-shaped clip (22). The upward movement of the clip (22) raises the actuating pin (20), which in turn lifts the sear (15) out of engagement with the head of the striker (13). The spring (14) drives the striker (13) onto the percussion cap (11a) which is in the holder (11) and fires it. This, in turn, fires the detonator and the main charge (3).

d. To disarm.—Carefully examine the mine for antilifting devices. If any are found, neutralize them and detach them from the mine. Avoid creating pressure on the tube (2) and sleeves (4). Insert a piece of stout wire or nail in the holes (18) at the ends of the strikers (13). Withdraw the actuating pins (20) and the cap holders (11) and remove the percussion caps (11a). Unscrew the nuts (9) and remove the tube (2) and sleeves (4) from the box (1). Carefully withdraw the sleeves (4) from the tube (2) and then remove the detonators from the charge (3).

e. To arm.—To arm the mine, withdraw both actuating pins (20) and both capholders (11), if in position. Unscrew the lock nuts (9) and remove the sleeves (4) and tube (2) from the box (1). Withdraw the sleeves (4) from the tube (2). Take out the two end blocks of high explosive charge (3) and insert a detonator, closed end inward, in the prepared hole in each block. Replace the blocks with open ends of the detonators projecting toward the openings (19) of the firing assembly bodies (10). Cock both strikers (13) and insert a safety pin in the hole (18) in the end of each striker (13). Fit the sleeves (4) onto the tube (2) and secure the complete assembly into the box (1) by means of the lock nuts (9). Insert the actuating pins (20) and withdraw the safety pins. Place a percussion cap (11a) in each cap holder (11) and insert the latter in the holes (12) until the retaining springs engage the slots in the capholders. The withdrawal of the safety pins may be deferred until all other arming

operations have been completed, but in this case it is essential that they be withdrawn by remote control.

[A. G. 300.7 (26 May 43).] (C 1, 30 Jul 43.)

92. Mine improvised from 2-kg aerial bomb (figs. 88 and 89).

* * * * *

a. Description.—This improvised antipersonnel * * * the screw bolt. Figure 89 shows the firing device adaptation in the armed condition.

* * * * *

[A. G. 300.7 (26 May 43).] (C 1, 30 Jul 43.)

93.1 (Added). Antipersonnel bomb 4 A. R. (Thermos) (fig. 90.1).—This bomb is designed to arm itself *after* it has come to rest on the ground. It becomes, therefore, an unexploded bomb (UXB) and is, in some respects, an antipersonnel mine. It is provided with a “Manzolini fuze” which is both antihandling and antidisturbance and is extremely sensitive to a jerk or a jolt. It has been given the name “Thermos” because of its resemblance to a thermos bottle.

a. Description.—This bomb consists of a cylindrical body (1) painted buff or green, a conical aluminum cup (2), and an arming cap (3). The bomb weighs 8½ pounds of which 1⅓ pounds is the explosive charge. The aluminum cup (2) has three projecting tabs (4) formed by cutting the metal and bending the tabs outward. The cap (3) holds the cup (2) in place and is provided with vanes (5) through one of which passes a safety pin (6) engaging a slot (7) in the cup (2). When the cap (3) and the cup (4) are removed (see fig. 90.1, (B)), the following parts of the bomb are exposed: a black steel collar (8), a heavy steel spring (9), and a brass fuze cover (10). In this condition, the fuze is completely watertight and sealed against the entry of grit which might impair its sensitiveness. The bomb has a lethal radius of 100 feet and a radius of flying fragments of 300 yards.

b. Employment.—There is no definite information on the employment of this bomb but due to its design it may be employed as an antipersonnel mine.

c. Operation.—After the bomb has been armed as described in *e* below it will explode under any sudden jerk or jolt.

d. To disarm.—As the Manzolini fuze is very sensitive to handling or other disturbance, the UXB mines cannot be disarmed but must be destroyed at the site. This can be done by small-arms fire, by a 1 ounce gun cotton primer charge or a stick of gelignite. A manual method of destroying the bomb is to place a loop loosely over the coils of the spring (9) which, when jerked sufficiently, will detonate the

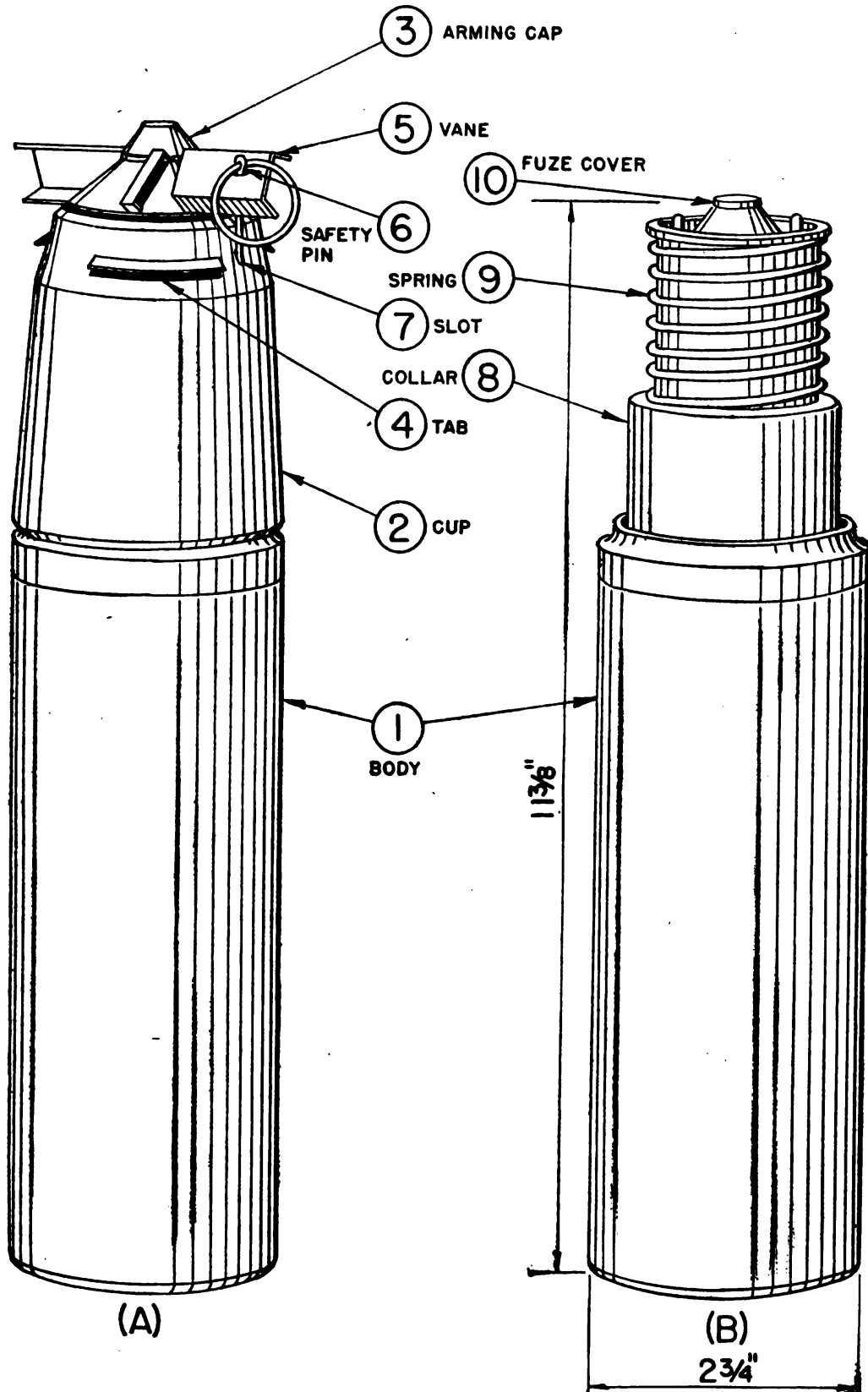

FIGURE 90.1.—Antipersonnel bomb 4A.R. (thermos).

bomb. A few sandbags between the bomb and the operator will give sufficient protection. However, 200 feet of rope should be used and the operator should be lying prone when giving the jerk. If circumstances demand the removal of the bomb before detonation, the following precautions should be taken: since the bomb is in its most dangerous position *when verticle*, as shown in figure 90.1 (B), never turn it into this position when picking up the bomb. Hold the bomb *horizontally*, and in picking it up and bringing it to this position do not turn it through the vertical position. Exercise great care in picking up, carrying, and laying down this bomb to avoid any jerking or jolting. All movements must be slow and deliberate and excessive acceleration of the bomb must be avoided. For the above reasons, in only exceptional cases should the bomb ever be moved.

e. To arm.—Before the bomb is dropped from its carrier, the safety pin (6) is removed. As the bomb falls, the vanes (5) cause the cap (3) to rotate and unscrew itself from the bomb. Then the cup (2) assisted by the projecting tabs (4), pulls itself off the bomb and falls away. The removal of the cup (2) releases six clips which form the primary safety devices for the Manzolini fuze. When the bomb strikes the ground, secondary safety devices are released and the arming of the fuze is completed after a delay period of a few seconds. This delay period enables the bomb to come to rest before the fuze becomes completely armed. Since completion of the arming process takes place internally no information is available covering the internal arming mechanisms or devices. Figure 90.1 (B) shows the appearance of the bomb when found in a dangerous condition.

[A. G. 300.7 (26 May 43).] (C 1, 30 Jul 43.)

93.1 (Added). Antipersonnel picket type mine (fig. 90.2).—This new Italian antipersonnel mine was recently discovered in the front lines. Twenty mines are carried in a wooden box which also contains one mallet and one small metal covered wooden picket 15 inches long and 1½ inches in diameter.

a. Description.—The mine consists of a circular wooden peg (1), 10 inches high and 1¼ inches in diameter, the top end of which is inserted into a metal cylinder (2), 5¾ inches high. The overall dimension of the mine is 17 inches. Around the outside of the cylinder (2) is coiled a steel spiral (3), ⅛ inch thick and ⅜ inch wide, which forms shrapnel when the mine is exploded. The cylinder (2) contains the explosive charge (4) which consists of one Italian 3½-ounce bore hole charge, prepared to receive a detonator (5). To the top of the metal cylinder (2) is screwed a striker mechanism. This consists of a cap (6) to the top of which is screwed a striker housing

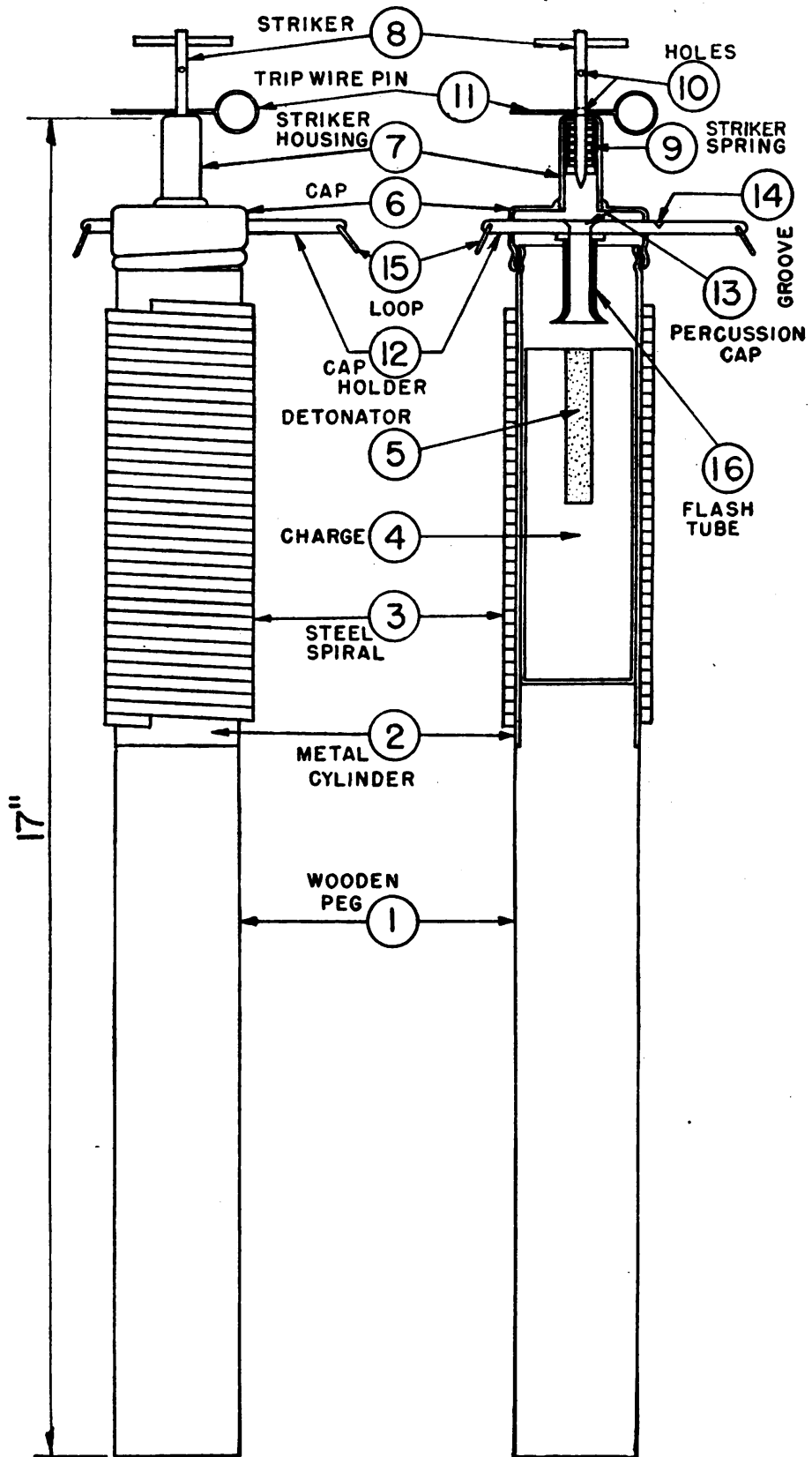

FIGURE 90.2.—Antipersonnel picket type mine.

(7). Within the housing (7) is a striker (8) and a striker spring (9). The striker (8) has two holes (10) drilled through it, one above the other. When the striker (8) is not cocked, the trip wire pin (11) is inserted through the top hole (10). To cock the striker (8) the latter is raised and the pin (11) is inserted through the bottom hole (10). An aluminum cap holder (12) slides through the cap (6) and is 2½ inches long, ½ inch wide and ¼ inch thick. The cap holder (12) is provided with a hole on one side to take the percussion cap (13) and a small groove (14) on the other side to engage the head of the striker (8) when the mechanism is uncocked. A triangular loop (15) is attached at each end of the cap holder (12). In addition, the rounded edge of a strip of spring steel, not shown in the figure, engages in a groove on the side of the cap holder (12) and thus positions it. Below the cap holder (12) is located a flash tube (16) which is riveted to the cap (6). The total weight of the mine is 1¾ pounds.

b. Employment.—This is an antipersonnel mine the detailed employment of which has not been reported.

c. Operation.—When the trip wire pin (11) is withdrawn the striker (8) is forced downward by the compression of the striker spring (9) onto the percussion cap (13). The flash from the cap (13) travels through the flash tube (16) and ignites the detonator (5) which explodes the main charge (4) and fragments the steel spiral (3).

d. To disarm.—Avoiding all trip wires, slide the cap holder (12) across so that groove (14) is under the striker (8). Inspect the trip wire attached to the pin (11) and then cut it. Hold the striker (8) and remove the pin (11). Lower the striker (8) and reinsert the pin (11) in the upper hole (10). Unscrew the cap (6) and remove the detonator (5).

e. To lay and arm.—Drive the metal covered wooden picket into the ground with the mallet to make the necessary hole, then withdraw the picket. Insert the mine upright into the hole up to the top of the wooden peg (1). Insert the detonator (5) and screw on the cap (6). Lay out the trip wire. Raise the striker (8) and insert the pin (11) through the bottom hole (10). Attach the trip wire to the pin (11). Finally, place the percussion cap (13) in the cap holder (12) and push the cap holder (12) over to the armed position. In this position, the percussion cap (13) is directly below the striker (8). When laid, 7½ inches of the mine are above the ground.

[A. G. 300.7 (26 May 43).] (C 1, 30 Jul 43.)

93.3 (Added.) Antipersonnel improvised mine (fig. 90.3).—This improvised mine is said to have been constructed by the Italians in large numbers at Tobruk. It is constructed from British gasoline cans rolled flat through a hand roller.

a. Description.—The mine has a 6-inch square base (1) in the center of which is a circular impression slightly larger than the diameter of a hand grenade. A hole is punched in the center of the base (1) in which a metal spike (2) $1\frac{1}{8}$ inches long by $\frac{5}{8}$ inch in diameter is sol-

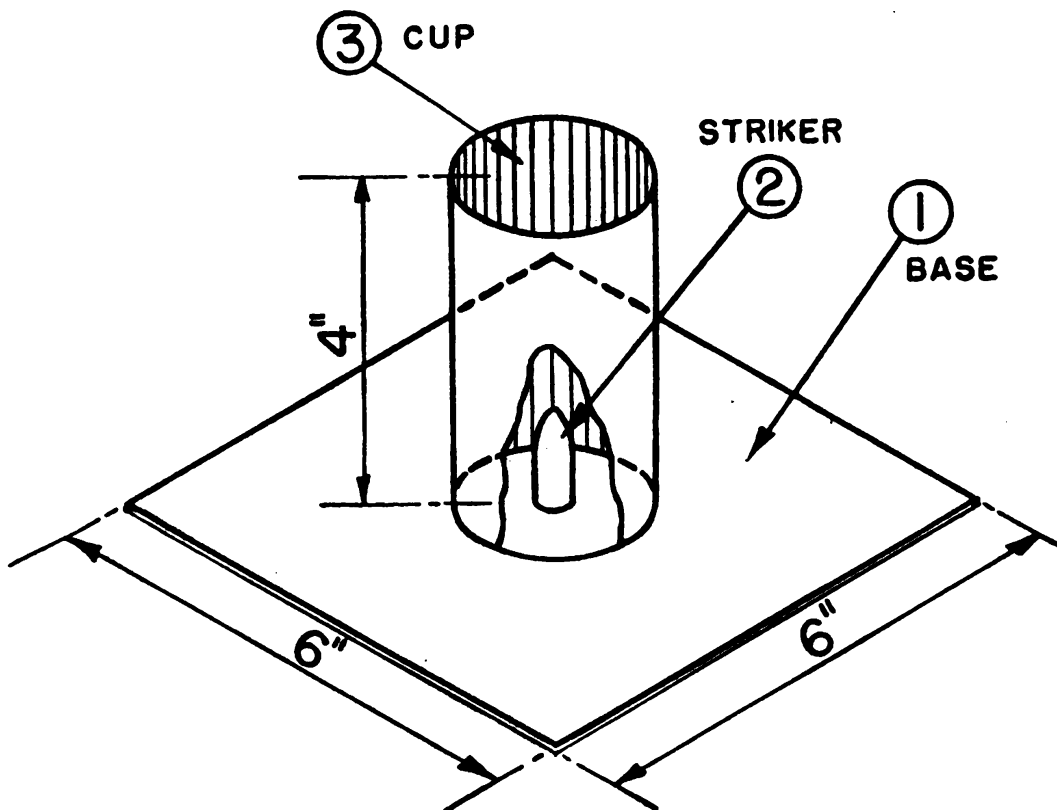

FIGURE 90.3.—Antipersonnel improvised mine.

dered to serve as a striker. A strip of tin is curved to form a cylinder or cup (3) which is soldered to the outside edge of the circular impression in the base (1). The striker, detonator and fuze are removed from an ordinary hand grenade and a special instantaneous fuze inserted in their place. The grenade is then placed in the cup (3) in such a way that the metal spike (2) becomes the striker of the grenade.

b. Employment.—The complete assembly is placed in the ground with the base (1) uppermost on the surface of the ground.

c. Operation.—When a person steps on the base (1) the hidden grenade explodes.

[A. G. 300.7 (26 May 43).] (C 1, 30 Jul 43.)

SECTION VII (ADDED.)

ITALIAN MINE FIELDS

95.1 General.—A special order on the use of mines issued by Headquarters of the 10th Italian Army Corps at El Alamein states that the purpose of mine fields is to prevent the approach and breakthrough of an enemy and to invite the enemy to enter the delaying zone, then destroy him with the mines themselves and with the fire of the troops surrounding the delaying zone.

[A. G. 300.7 (26 May 43).] (C 1, 30 Jul 43.)

95.2 Mine field lay-out.—*a. Density.*—Regular pattern mine fields should have a density of one mine per meter (39 inches) of front.

b. Observation mines.—These mines are continually under observation and are laid approximately 438 yards in advance of the first row of mines in the mine field. Any type of mine may be employed, including aerial bombs. They are especially placed in the outer mine fields, gaps that an enemy is bound to use, and in zones where a break-through is likely. The mines are fired by "observers" after an enemy's presence has been observed, by means of a charge with an electric detonator. Many of these observation mines are fitted with secondary firing devices as booby traps.

c. Mining of barbed wire.—Barbed wire is reinforced with hidden explosives and Italian pressure mines. Small explosive charges armed with pull igniters are attached to the barbed wire so that any disturbance of the wire detonates the charges. The 2-kg aerial bomb, adapted as an antipersonnel mine (see par. 92) is placed between wire fencing.

[A. G. 300.7 (26 May 43).] (C 1, 30 Jul 43.)

CHAPTER 4

JAPANESE LAND MINES AND DEVICES

100.1 (Added). New antitank mine.—*a. Description.*—This new Japanese mine, whose dimensions have not been reported, has the appearance of two pieplates placed with the concave sides together. It has a muddy brown color and contains from 7 to 10 pounds of TNT.

b. Employment.—These mines are usually placed across a road and are very effective against wheeled vehicles and medium tanks.

[A. G. 300.7 (26 May 43).] (C 1, 30 Jul 43.)

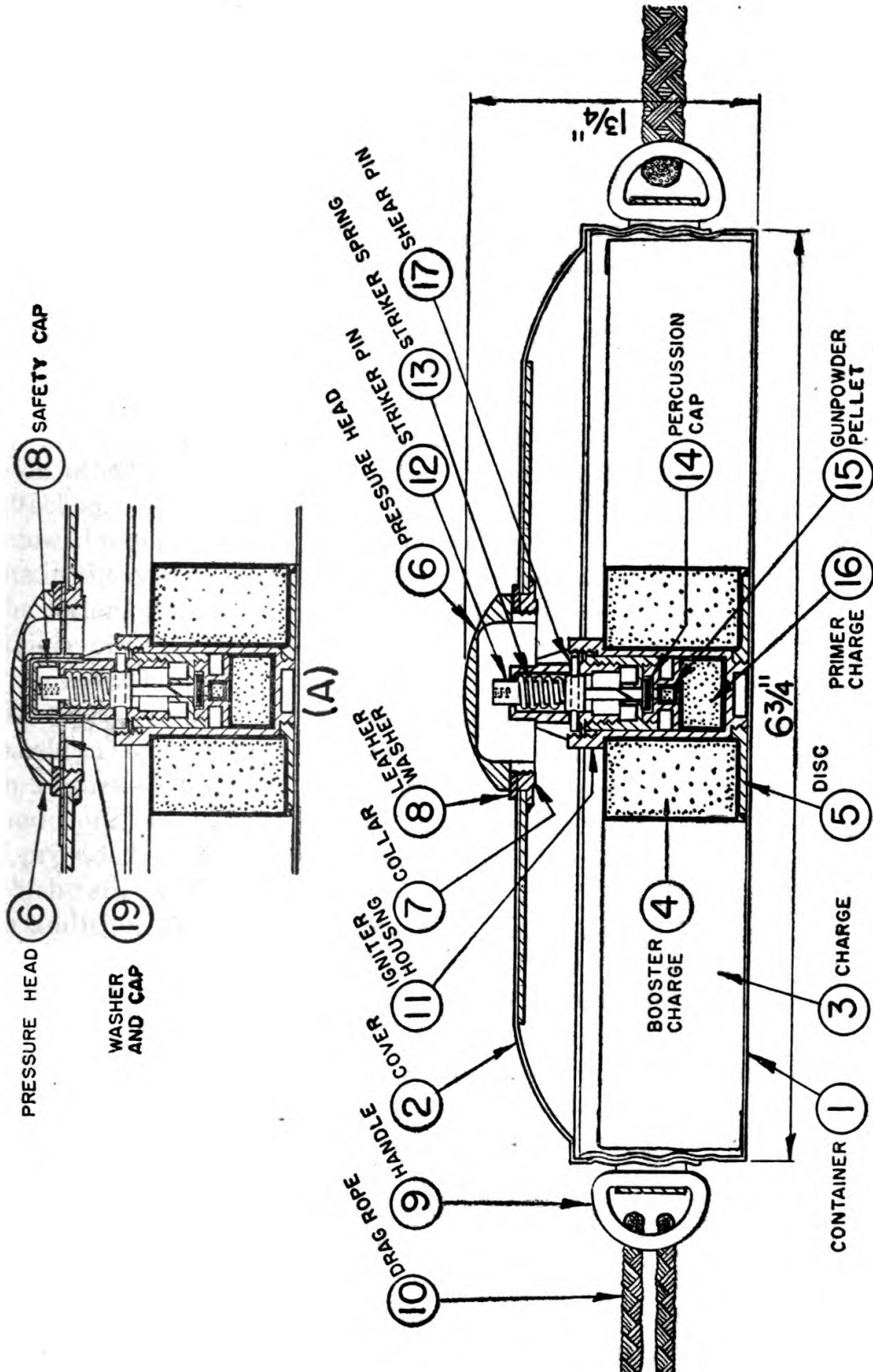

FIGURE 97.1.—Antitank mine, type 93.

100.2 (Added). Antitank mine type 93 (fig. 97.1).—This mine has been found by the Australians and was used by the Japanese on the New Guinea front.

a. Description.—This mine consists of a cylindrical tin plate container (1) and a slightly domed cover (2) which screws onto the container (1). Within the container (1) is placed a 2-pound ring charge consisting of cast picric acid (3) and a booster charge (4) of pressed powdered picric acid. The central opening in the charge is $\frac{5}{8}$ inch in diameter and is lined with a cardboard tube. Soldered in the center of the container (1) is a brass disk (5) having an internally threaded collar. The cover (2) has a knurled brass plug or pressure head (6) which screws into a collar (7) soldered to the under side of the cover (2). To seal the opening in the cover (2) a leather washer (8) is provided. On the sides of the cover (2) and diametrically opposite each other are fastened handles (9) to which drag ropes (10) are attached. The igniter assembly housing (11) is made up of four parts screwed together and contains the striker assembly. The housing (11) fits in the central opening of the ring charge (4) and is screwed into the collar of the brass plate (5). The igniter assembly consists of a striker pin (12), a striker spring (13), a percussion cap (14), a pellet of gunpowder (15), and a primer charge (16) consisting of a pellet of tetryl surrounded by a layer of lead oxide. The striker spring (13) is held in compression by a shear pin (17) which is $\frac{3}{32}$ inch in diameter. In Figure 97.1 (A) the igniter assembly is shown in the unarmed condition. In this condition the upper end of the striker pin (12) is provided with a threaded hole to receive a brass safety cap (18) which relieves the pressure of the spring (13) on the shear pin (17). In addition a combination brass washer and cap (19) rests on the igniter assembly housing (11) and has a lug which projects beyond the leather washer (8) showing the Japanese ideograph for "safe" marked on it. The total weight of the mine is 3 pounds.

b. Employment.—Three uses for this mine have been reported.

(1) Drag ropes (10) are attached to the handles (9) enabling the mine to be used as a "walking" mine by being pulled manually in front of a tank or vehicle.

(2) A light rope is attached to one of the handles (9) enabling the mine to be hurled a distance of 15 feet in front of an advancing tank or vehicle.

(3) Several mines are sometimes strung on a rope 150 feet long which are dragged across the path of tanks or vehicles by two operators.

c. Operation.—After the mine has been armed a pressure of approximately 250 pounds on the pressure plug (6) will shear the shear pin

(17). The striker (12) is then driven downward by the spring (13) and fires the cap (14). The cap, in turn, fires the pellets (15) and (16), the booster charge (4) and the main charge (3) thus detonating the mine.

d. To disarm.—The area around the mine should be examined for traps. Without moving the mine or exerting any pressure on the cover (2), unscrew the knurled pressure plug (6). If the brass safety cap (18) is available screw it firmly into the top of the striker (12). This action neutralizes the mine. To disarm the mine, unscrew the igniter assembly housing (11) from the base of the mine.

e. To arm.—If the mine is in the condition shown in figure 97.1 (A), unscrew the plug (6) and remove the washer (8). Take off the combination washer and cap (19) and unscrew the safety cap (18). Replace the washer (8) and rescrew the plug (6) in place. The mine is now armed.

[A. G. 300.7 (26 May 43).] (C 1, 30 Jul 43.)

101. Magnetic antitank mine (figs. 98 and 99).—

* * * * *

b. Employment.—These mines are used * * * weapons to destroy it. Used singly, penetration is effective against ¾-inch steel. It is most commonly used by linking two mines together by putting opposite poles together. The effective adhesion of the magnets depends upon the age of the mine and the conditions under which it has been stored.

c. Operation.—The mine operates * * * which is fired. The cap ignites the delay fuze and 5 seconds afterwards, the detonator is fired and the charge is exploded.

* * * * *

[A. G. 300.7 (26 May 43).] (C 1, 30 Jul 43.)

SECTION III (ADDED.)

JAPANESE MINE INSTALLATIONS

101.1. General.—Reports from the Far East show that all units of the Japanese Army are trained extensively in the use of antitank mines. These mines are laid in the conventional manner covering the logical routes of approach for tanks. Bridges in defensive areas are habitually mined. Any bridge which has been in Japanese hands must be examined carefully for the presence of contact mines before a tank unit can be allowed to cross. Antitank barricades may be expected to have all possible detours heavily mined. It is common

practice also to lay a few mines under temporary barricades with the idea that anyone removing the barricades will not suspect that mines have been laid in the ground underneath:

[A. G. 300.7 (26 May 43).] (C 1, 30 Jul 43.)

101.2. Japanese use of antipersonnel mines and booby traps.—A recent report on a Japanese training manual dealing with the laying of antipersonnel mines and booby traps shows the following typical examples: A grenade or high-explosive charge fitted with a pull igniter and attached to a door by wire; charges presumably fitted with release igniters placed under large stones on a road; two charges connected by a wire 4 inches above the surface of the ground; a charge tied to a live shell with its igniter connected to some object, such as a rifle; felled trees forming a road block attached by wire to a buried charge, which fires when the trees are moved. These examples are of certain interest as the Japanese are inclined to follow in detail the procedure laid down in their manuals.

[A. G. 300.7 (26 May 43).] (C 1, 30 Jul 43.)

CHAPTER 5

FRENCH TYPE MINES AS CAPTURED OR PROCURED BY THE GERMANS

102. French light antitank mine.—

* * * * *

b. Employment.—Mines of this * * * injure its crew. In North Africa this mine was found connected by primacord to British 40-pound aerial bombs whose nose caps were removed. The mine was also found laid on a standard German prepared charge with the flange of the container (1) (see fig. 100) connected to a Z. Z. 35 standard pull igniter fitted to the prepared charge.

[A. G. 300.7 (26 May 43).] (C 1, 30 Jul 43.)

INDEX

	Paragraph	Page
* * * * *		
Friction igniter:		
German:		
B. Z. 24 with delay pellet-----	25	18
B. Z. E. with delay pellet-----	24	17
Nb. B. Z. 38 with delay pellet-----	25	18
Zdzchn. Anz. 29-----	23	15
Japanese-----	96	152
* * * * *		
Pull igniter:		
Z. u. Z. Z. 35-----	27	21
Z. Z. 35 (mechanical)-----	26	20
* * * * *		
[A. G. 300.7 (28 May 43).] (C 1, 30 Jul 43.)		

BY ORDER OF THE SECRETARY OF WAR:

G. C. MARSHALL,
Chief of Staff.

OFFICIAL:

J. A. ULIO,
Major General,
The Adjutant General.

TECHNICAL MANUAL }
 No. 5-325

WAR DEPARTMENT,
 WASHINGTON, April 19, 1943.

ENEMY LAND MINES AND BOOBY TRAPS

CHAPTER 1. General.	Paragraphs
SECTION I. General	1-6
II. Types of mines	7-13
III. Booby traps	14-19
CHAPTER 2. German land mines and devices.	
SECTION I. General	20-21
II. Standard firing devices (igniters)	22-32
III. Standard detonators	33-35
IV. Prepared charges	36-42
V. Light antitank mines	43-45
VI. Heavy antitank mine	46
VII. Railway mine	47
VIII. Antipersonnel mine	48
IX. Improvised mines	49-65
X. Booby traps	66-69
XI. Mine fields	70-73
CHAPTER 3. Italian land mines.	
SECTION I. General	74-75
II. Antitank mines	76-87
III. Railway mine	88
IV. Antipersonnel mines	89-93
V. Dual purpose mine	94
VI. Booby traps	95
CHAPTER 4. Japanese land mines and devices.	
SECTION I. Firing device and detonator	96
II. Antitank mines	97-101
CHAPTER 5. French type mines as captured or produced by the Germans	102
INDEX	165

CHAPTER 1

GENERAL

	Paragraphs
SECTION I. General	1-6
II. Types of mines	7-13
III. Booby traps	14-19

SECTION I

GENERAL

	Paragraph
Purpose and scope	1
References	2
Passage of mine fields	3
Antipersonnel mining and booby trap practice	4
Antitank mining practice	5
Definitions	6

1. Purpose and scope.—This manual summarizes available information on the design and construction of German, Italian, and Japanese land mines and booby traps from examination of captured mines and booby traps and from Military Intelligence documents. The information presented does not cover the tactical employment of land mines and booby traps by foreign armies. It is intended primarily to describe the construction of enemy land mines and booby traps for the benefit of engineer troops who will be engaged in their neutralization and disarming in the passage of mine fields. Familiarity with this manual will facilitate recognition of the various types of mines and will assist in rendering the mines safe for removal and disposal, or perhaps for storage and later counteremployment against the enemy. Neutralization and disarming of enemy mines and booby traps are extremely hazardous. They should be undertaken only by troops trained for the purpose. An alternative to neutralization is the demolition of enemy land mines in place, or at least of sufficient mines to provide passage lanes for attack by our own troops. This alternative may be necessary because of the delays and the hazards entailed in locating and neutralizing the many types of enemy land mines which it may be expected will be encountered. Neutralization and removal of mines at night or under concealment as by smoke or fog, to provide lanes for the passage of attacking troops, may, however, be required to preserve the element of surprise. Decision to neutralize and remove mines will depend on the tactical situation, on familiarity with the enemy's tactical employment of land mines and booby traps and the types he employs, and on availability of engineer and other troops.

Neutralization, disarming, and removal or demolition of enemy land mines is a command decision. Engineer recommendations are considered carefully.

2. References.

FM 5-5, Troops and Operation.

FM 5-15, Field Fortifications.

FM 5-25, Explosives and Demolitions.

FM 5-30, Engineer Antimechanized Measures.

FM 5-35, Reference Data.

TM 9-1900, Ammunition, General.

TM 9-2900, Military Explosives.

Training Circular No. 29, War Department, 1942, Antitank Mine Fields.

Training Circular No. 38, War Department, 1942, Antitank Mine Platoon, Antitank Company, Infantry Rifle Regiment.

Training Circular No. 75, War Department, 1942, Antipersonnel Mines and Booby Traps.

3. Passage of mine fields.—The tactics of crossing mine fields are similar to the tactics used in river crossings. See FM 5-30, as amplified by Training Circular No. 14, War Department, 1943, which is supplemented by this manual.

4. Antipersonnel mining and booby trap practice.—Training Circular No. 75, War Department, 1942, presents information on the employment of antipersonnel mines and booby traps by our own troops. Familiarity with this training circular will assist in an understanding of foreign antipersonnel mines and booby traps and the methods of their employment.

5. Antitank mining practice.—Antitank mining tactical employment and technique of our Army is described in current Training Circular No. 20, War Department, 1943. Familiarity with this training circular will assist in understanding the tactical practice and technique of employment of antitank mines by foreign armies.

6. Definitions.—A glossary of general terms used in ammunition practice is published in TM 9-1900. The publications listed in paragraph 2 further illustrate the terminology in vogue in our Army. The following definitions are given, however, to repeat and extend the terminology to meet the needs of this manual:

a. Land mines.—A land mine consists of an encased charge of explosive with detonating device or devices designed to be actuated by the passage of vehicles or personnel. The term "land mine" applies to both antivehicle and antipersonnel mines and is used in a general sense to distinguish the Army's mines from those of the Navy. For reasons of safety in handling, the main explosive charge of the mine usually

is comparatively insensitive, and some means (firing device and detonator) must be provided so that the initiating action (passage of vehicles or troops) will set up a chain of events leading to the explosion of the main charge. The most common types of mines (nonelectric) employ devices which operate through the sequence of events shown diagrammatically in figure 1. In many mines the main charge is sensitive enough to be exploded directly by the detonator, and the booster charge shown in figure 1 is then omitted.

b. Antipersonnel mines.—An antipersonnel mine is designed for effect against personnel and, as distinguished from a booby trap, is laid to perform a definite tactical mission. Antipersonnel mines are used in antitank mine fields to give warning of enemy mine removal parties as well as for effect against the parties. They are laid in other obstacles, such as wire entanglements, for a similar purpose. They are also laid as antipersonnel mine fields to deny the enemy the use of favorable assembly areas or approaches and to give warning of enemy approach in such areas under cover of darkness or smoke.

c. Booby traps.—Booby traps are installed to operate against personnel in territory surrendered to the enemy. They are designed to function by themselves and to harass or destroy individuals or small groups of the enemy, usually over a prolonged period. In many cases the same device may be used for either an antipersonnel mine or booby trap. The classification is determined by the purpose for which installed. (See sec. III.) Booby traps may be used in conjunction with antivehicle (antitank) mines to lend variety and deception to the mining practices and to destroy an unwary enemy.

d. Firing device.—The term “firing device” as used herein is an inclusive one and applies to any and all of the following: igniter, trip mechanism, switch, fuze, time fuze, primacord (cordtex), and delay action fuze, according to differences in mechanism described later in the manual. The firing device produces the flame or concussion to set off the detonator which, in turn, or through a booster charge, explodes the mine. The various types of firing devices are designed to operate through the application or release of pressure, by the pulling of a trip mechanism, through the release of a tension wire or other tension device, or by means of a delay action mechanism. Three of the more common principles upon which firing devices operate are as follows:

(1) *Percussion firing.*—A percussion igniter consists generally of a percussion cap which is set off by the impingement of a spring actuated striker or firing pin released mechanically. The mechanical release of the firing pin or striker is usually accomplished through the application of either pressure or tension to locking or release devices contained in the igniter. The locking or release device becomes unlatched

through the applied actuating force. This type of firing is commonly found in both foreign and United States practice.

(2) *Friction igniter*.—Friction igniters are comprised of substances which are set aflame or are exploded under the action of applied friction. Friction igniters are generally of low intensity and are insufficient to fire mine or booby trap charges directly. They act through detonators of higher explosive intensity. Friction igniters employed in mines and booby traps are generally fired by the friction created when a wire which has been cast integrally with the frictional substance is pulled through the substance. To increase the friction created in drawing or pulling the friction wire through the frictional substances, the friction wires are generally kinked or twisted at the free end which is drawn through the friction substance.

(3) *Firing through chemical reaction*.—Chemical reaction between selected substances, resulting in a high intensity flame, may be used to ignite a detonator. One firing device of this type consists of a glass vial of sulphuric acid inserted in a mixture of equal parts of potassium chlorate and sugar. Pressure on the firing device sufficient to effect the breakage of the vial will cause an intermixing of the acid with the potassium chlorate and sugar. The intermixture of these substances produces a high intensity flame which, in turn, ignites a detonator.

e. Detonator.—A charge of high sensitivity used in an explosive train is termed a detonator. A detonator is fired by flame or spark, either transmitted directly from a percussion cap, through a fuze, or through the firing of a frictional substance, or in the case of an electrical detonator, by heat or spark from an electric current. The detonator may explode a mine or booby trap charge directly or through the intermediate explosion of a booster charge.

f. Booster.—In cases where the main charge is so insensitive that it cannot be exploded directly by the detonator, a booster or primer charge is introduced. The detonator sets off the booster which, in turn, explodes the main charge.

g. Primer.—A charge, generally of the same explosive as the main charge, and which is therefore an element of the main charge. It is provided with a detonator which explodes the main charge. It is termed the "primer" or the "primer charge." In demolition practice the primer ordinarily would be the block of TNT or stick of dynamite of a charge of TNT or dynamite respectively, in which the detonator is fixed for firing the charge. The explosive characteristics of both commercial and military explosives are such that they do not require a detonator for each element of the charge, hence the element which contains the detonator is termed the primer or primer charge.

h. Secondary firing device.—The term “secondary firing device” is used in this manual to indicate a supplemental or additional firing device which functions independently of the main firing device. One or more secondary firing devices of either the push, pull, or release types may be laid in conjunction with an antitank mine for the purpose of causing an explosion upon attempted removal of the mine. Such secondary firing devices are, in effect, booby traps designed to deceive and destroy a careless or unwary enemy.

i. Fuze.—A fuze is a tube or cord filled or impregnated with combustible material. It is used for igniting an explosive charge after a predetermined delay. A mechanical device designed to initiate the function of ammunition (mine or booby trap) under the circumstances desired may also be called a fuze. As frequently used by foreign armies the term “fuze” is an inclusive one embracing all elements of the firing devices used to actuate land mines and booby traps. The fuze of the U. S. Army antitank mine, HE, MI, is described in current training circulars as consisting of a striker assembly, body, primer, detonator, and booster. As used in demolition practice the term “fuze” describes the nonelectric tubular firing medium containing in its interior a combustible or low order explosive material designed to burn at a fixed rate to set off a detonator and charge.

(1) *Time fuze and delay action fuze.*—The time fuze and delay action fuze are mechanically or chemically controlled detonating devices. The controlled timing element in the fuze differentiates it from the other firing devices.

(2) *Instantaneous fuze.*—The instantaneous fuze is a tube filled with or a cord impregnated with a compound which burns at a very rapid rate, that is, at about 120 feet per second.

(3) *Safety fuze.*—The safety fuze is a tube filled with or a cord impregnated with a relatively slow-burning compound, that is, a compound which burns at about 2 feet per minute. The time fuze used in our Army is also known as “safety fuze.”

j. Primacord (cordtex).—The term “cordtex” is synonymous with the term “primacord” and the term “detonating cord” as used in our Army. It consists of a flexible, waterproof fabric tube of small diameter (generally less than $\frac{1}{4}$ inch) with an explosive core. It is quite insensitive to shock, flame, or friction and requires a cap to detonate it. The extreme violence of the explosion of primacord (cordtex) is sufficient to detonate other explosives in intimate contact with it. It is particularly valuable for the safe priming of charges and for the simultaneous priming of a number of charges at some distance apart.

k. Charges.—A charge is the explosive used for a single discharge, burst, or blast.

l. Demolition charge.—A demolition charge is one used to destroy material, equipment, or structures.

m. Prepared charge.—A prepared charge is a packaged charge equipped with a holder or recess to receive a detonator. The charge may be any shape or size and may be inclosed in containers of various materials. Prepared charges may be grouped to form demolition charges of any desired weight.

n. Sympathetic detonation.—Detonation which is induced by an explosion of another charge nearby is termed "sympathetic." It is also known as "induced detonation." The main explosive charge of a mine is normally not sensitive enough to be exploded through sympathetic detonation. Such detonation is normally due to pressure arising from an adjacent explosion, acting on the detonator of the mine fired sympathetically. Thus the pressure wave created by the explosion of a mine in the near vicinity may actuate other mines equipped with pressure igniters through pressure action on the mine covers or other diaphragms connected to the pressure igniters. Mines equipped with "spiders" (such as the standard U. S. antitank mine) for actuating pressure igniters are only slightly responsive to pressure wave (sympathetic) firing and hence have greater flexibility of use as closer grouping may be resorted to without hazarding the pressure wave firing of an entire mine field through the explosion of one mine. The solid top rather than spacing of the spider top is limited by responsiveness to induced detonation.

o. Igniter.—This is an inclusive term used in the same sense as the term "fuze" is sometimes used and connotes the devices, caps, detonators and boosters which are employed in exploding a land mine or booby trap charge. The terms "igniter" and "igniter assembly" are used interchangeably and have the same meaning in describing in an inclusive sense the firing mechanism consisting of striker, spring, latches and releases, and the detonator, cap, fuze, or other exploding element of a mine or booby trap.

p. Trip cord or wire.—This is a cord or wire attached to the igniter of a mine or booby trap for the purpose of actuating the igniter, and thus the mine or booby trap, by the inadvertent disturbance of the cord or wire, resulting in its being pulled or released.

q. Delay pellet.—This is a small pellet of powder, usually compressed which, after being ignited, takes a predetermined time to burn through and to ignite a fuze or detonator or an explosive charge.

r. Friction wire and friction composition.—In certain igniters the heat generated by the friction of a wire pulled through a chemical composition causes a flame. The wire is known as a friction wire

and the composition through which it is pulled, friction composition or friction substance.

s. *To arm.*—To arm means to prepare a mine so that it will explode when actuated by a vehicle or person.

t. *To neutralize.*—To make a mine or booby trap safe by rendering the firing device or igniter safe. This is generally accomplished by placing a nail or split pin in a safety pin hole in the firing device. In the following discussion of the individual mines, instructions are given for neutralizing each one. It must be remembered that a mine is not necessarily safe after the main firing device has been neutralized, since the mine may have one or more secondary firing devices which, unless also neutralized will set off the mine if it is handled or disturbed.

u. *To disarm.*—To remove or disconnect the firing device or detonator, or both, from the mine, thereby making the mine safe to handle. The disarming of a mine is always preceded by neutralizing the firing device; hence the action of disarming a mine is one of rendering the mine completely innocuous by extracting the firing element or elements from the mine body, as distinguished from neutralizing which consists of utilizing either the safety devices or substitutes of similar form, for locking the firing devices of the mine so that they can not be actuated by normal procedures.

v. *Antilifting device.*—A secondary firing device, which will explode the mine if it is lifted, is known as an "antilifting device."

w. *Density of mine field.*—The density of a mine field is the number of mines in the field per yard of front.

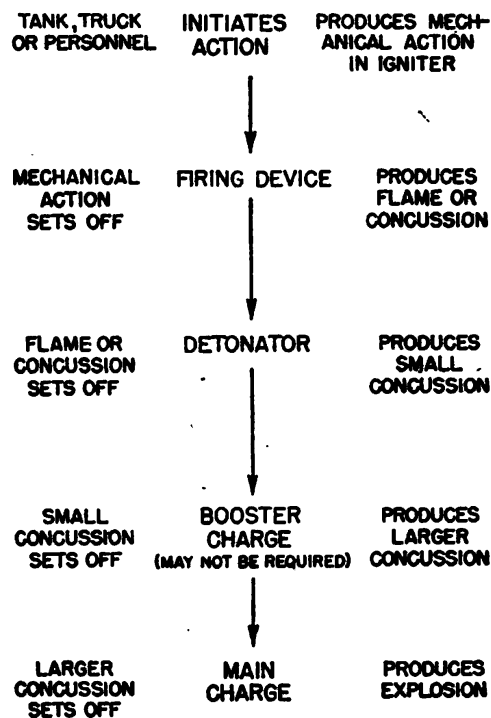

FIGURE 1.—Diagram of firing action.

SECTION II

TYPES OF MINES

	Paragraph
Light antitank-----	7
Heavy antitank-----	8
Antipersonnel-----	9
Improvised-----	10
Railway-----	11
Road and field-----	12
Dummy-----	13

7. Light antitank.—Light antitank mines are designed to immobilize vehicles by breaking the track or wheels. The complete destruction of the tank must then be accomplished by the fire of covering antitank weapons or specially placed charges. The light antitank mine generally contains from 4 to 12 pounds of explosive.

8. Heavy antitank.—Heavy antitank mines produce serious damage to tracks, wheels, and tank bodies and have been known to overturn 20-ton tanks. Their explosive charge generally weighs about 40 pounds.

9. Antipersonnel.—Antipersonnel mines are those designed to operate against enemy personnel. They are set off by either standard or special firing devices. These mines are placed with a definite tactical purpose such as the protection of an antivehicle mine field or other type of obstacle, or to provide local security, since their detonation will give warning of the approach of hostile troops.

10. Improvised.—Improvised mines may be used as antitank mines, antipersonnel mines, or as booby traps. They may use any of the standard explosives and may be set off by either standard or improvised detonators and firing devices. The explosive and the firing devices may be connected in numerous ingenious ways, or standard mines and firing devices may be considerably altered to operate in a manner different from that for which originally designed. Improvised mines are dangerous and time-consuming to install, but are used frequently when standard devices are not available, or when it is desired to introduce new types of mines. They may operate against either vehicles or personnel. They may use standard munitions.

11. Railway.—These mines may be electrically or mechanically operated. They are designed to be used under railroad ties or sleepers so that they will explode when a train passes, or explode after a set period of time has elapsed.

12. Road and field.—This mine is a type which can be used as a dual purpose mine, that is, either as an antipersonnel or antivehicle

mine. The title by which this is known emphasizes the double use to which it may be put.

13. Dummy.—Dummy mines are nonactive imitations of live mines. Their main purpose is to confuse as well as delay the enemy. They are sometimes laid in a poorly concealed manner so as to distract the attention of the enemy from a live mine.

SECTION III

BOOBY TRAPS

	Paragraph
General.....	14
Operation.....	15
Employment.....	16
Detection.....	17
Neutralization, disarming, and removal.....	18
Special precautions.....	19

14. General.—A booby trap is any form of concealed mechanism placed in such a position that it will inadvertently be actuated by the enemy, or function automatically by means of a time mechanism. Booby traps may be used against personnel, vehicles, equipment, or communications. They may consist of antivehicle or antitank mines or of prepared charges detonated by either standard or improvised firing devices. Booby traps may also be designed to ignite flares and incendiary bombs, and may be used in conjunction with antitank mines. They are generally placed in and around buildings, or connected to abandoned vehicles or articles of equipment, such as helmets, automobile tires, and firearms. Against personnel they are set off by acts of carelessness or curiosity. Although booby traps are used largely against personnel, they are not considered antipersonnel mines, since their purpose is to harass and demoralize the enemy rather than to provide protection or security for our own forces. The casualties and damage inflicted are merely a means toward an end. The distinction between booby traps and antipersonnel mines is in the employment rather than in the operation of the mechanisms. Thus practically any mine designed for antipersonnel use may be rigged as a booby trap. Some antitank mines or standard high explosives may be used for booby traps. For example, a trip wire can be so arranged that it will pull out the shear pin from an antitank mine, producing detonation due to the action of a small force on the pin. Electrically fired mines, either antitank or antipersonnel, can readily be used as booby traps, since a number of arrangements may be devised for closing an electric circuit. Reference is made to Train-

ing Circular No. 75, War Department, 1942, for information on booby traps as developed and employed by our Army.

15. Operation.—As booby traps rely for their success entirely on surprise, the charge and operating mechanism either will always be concealed or made to resemble some common and harmless object. Booby traps are operated by one of the following methods:

a. The direct pressure of a foot, wheel, or track on the concealed mechanism.

b. The lifting of some apparently harmless object off the concealed mechanism.

c. The movement of some concealed object, such as a thin trip wire, connected to the concealed mechanism.

d. Some form of automatic delay mechanism designed to function independently of any human agency. This delay may be from a few hours to many days.

16. Employment.—Booby traps are installed to operate against personnel in territory surrendered to the enemy. They are used either in conjunction with a raid on hostile positions in order to cause casualties on reoccupation, or to deny approach of the enemy and, during an organized retirement, to slow up the enemy's advance. Traps have infinite variety in their distribution and use, and are dangerous to those who attempt to locate or remove them. Occasionally a second booby trap is placed underneath the first one in order to stop the first from being removed. Frequently dummy trip wires are laid in depth with a live trap mine every now and then, delaying passage, as every wire must be investigated. Training Circular No. 75, War Department, 1942, gives suggestions for installations of booby traps, and these will bring to mind other locations where traps are likely to be concealed. The design of such traps is adapted to suit the local features in each particular case, and in general the more varied their form, the more difficult their detection.

17. Detection.—*a.* The detection of booby traps and the reduction of casualties from them is largely a matter of discipline and training, combined with a knowledge of the subject and the development of the following capabilities:

(1) Keen eyesight coupled with quick appreciation of the significance of unnatural phenomena.

(2) Knowledge of enemy booby trap equipment and the normal method of employment.

b. Information regarding the sites and nature of traps can often be obtained from prisoners and local inhabitants. The types of traps and possible sites that may be encountered are innumerable, and their successful action can be circumvented only by a thorough, systematic

and conscientious search. Everything movable in a mined area must be treated with the greatest suspicion.

18. Neutralization, disarming, and removal.—The neutralization and disarming of booby traps is a hazardous occupation and every precaution must be taken to safeguard engineer personnel so employed. Examination, neutralization, and disarming of a trap should be carried out by one or, at the most, two persons, others remaining at a safe distance and, when considered desirable, recording the steps being taken. In this way, injuries and loss of life will be minimized and valuable records obtained. Engineer parties should be organized into two groups working at a distance, the first to examine and neutralize traps, the second to disarm and remove them. The locality to be examined should be first divided into zones, each of which must be cleared before proceeding to the next. When a trap is encountered, the method of operation must first be determined without handling or disturbing the mechanism. No attempt should be made to disarm a trap until its method of firing is understood. Then, and only then, should the trap be neutralized. Most standard mechanisms are fitted with one or more safety devices, usually in the form of a pin. The hole from which the pin has been withdrawn should be fairly obvious. A nail or piece of wire should be inserted to replace the safety pin at once. This will normally render the mechanism safe. Trip wires and leads must then be cut to disconnect the charge. However, the entire length of the trip wire must be examined to make certain that no trap is located at the opposite end and to insure that the cutting of the trip wire will not produce a detonation. Care must be taken that a firing circuit will not be completed (closed) by cutting a double electric lead with a pair of pliers, or that an electric relay will not be closed on breaking a circuit by cutting a lead. Delayed action traps will usually be difficult to locate except by electric mine detectors, since they require no external firing agency and, therefore, can be well concealed. They may fire with very slight disturbance, particularly toward the end of the delay period. They should, therefore, be destroyed in place by another charge whenever possible. If the resulting damage cannot be accepted, the fuze or leads connecting the device to the charge must be bared at a safe distance and cut. The charge can then be removed. In any event, the charge should be removed as soon as possible after the trap is neutralized. When time permits, suspected localities should be searched again to reveal the better concealed traps, including delayed action ones. However, there can be no guarantee that the site is completely free from traps.

19. Special precautions.—The instructions for the neutralization of foreign mines and booby traps set forth in this manual are explicit only for their normal design and construction as determined from captured mines and booby traps and as described in available Military Intelligence documents. The ingenuity of the enemy will lead him to develop and improve his mines and booby traps, so that similarity in form to those described herein may, in fact, be designed to deceive as to the method of firing. There is always the possibility of alterations in the field, or the use of secondary firing mechanisms and booby traps in conjunction with the various types of land mines; hence it is hazardous to assume familiarity with the mine encountered because this manual has been studied or because mines of similar appearances or type have previously been handled without accident. A “conceit of opinion” may result in serious accident. Every mine or booby trap should be viewed with caution and respect, and the neutralization and removal of *every mine or booby trap* should be considered a new problem in which nothing is taken for granted. The safe practice in the passage of a mine field is to fire sufficient mines to provide safe lanes or passageways for our own troops; decision as to whether destruction or removal of the remainder of the mine field will be undertaken should be delayed until the situation permits study and deliberate action free from haste or enemy activity. Booby traps constitute a special hazard, and the tactical commander under conditions of modern warfare will prohibit all but special engineer troops from entering areas which may be planted with booby traps. In case of doubt, booby traps or mines should be fired with explosives.

CHAPTER 2

GERMAN LAND MINES AND DEVICES

	Paragraphs
SECTION I. General-----	20-21
II. Standard firing devices (igniters)-----	22-32
III. Standard detonators-----	33-35
IV. Prepared charges-----	36-42
V. Light antitank mines-----	43-45
VI. Heavy antitank mine-----	46
VII. Railway mine-----	47
VIII. Antipersonnel mine-----	48
IX. Improvised mines-----	49-65
X. Booby traps-----	66-69
XI. Mine fields-----	70-73

SECTION I

GENERAL

	Paragraph
General-----	20
Types of mines-----	21

20. General.—Practically all German mines, including standard or improvised antitank and antipersonnel mines and booby traps, regardless of other differences and special features, are fired by one or more of several standard igniters (firing devices). Most German land mines and traps have certain other points in common, as follows:

a. All standard and special mines, blocks, and prepared charges have one or more holes drilled and threaded to receive the standard igniters described in section II.

b. In most cases, igniters can be made safe by means of a nail or piece of wire inserted in the safety pin hole provided in the standard igniters for a safety locking pin. The methods of neutralizing the various igniters are described in section II.

c. If time permits, booby traps are prepared in such manner as to operate by both pressure (applied weight or push) and tension (withdrawal of a locking pin or pull).

d. Dummy mines, of patterns similar to live ones, are used freely by the Germans to deceive and confuse. Dummy mines should be

examined with care; it should not be assumed by hasty examination that they are innocuous, as some of the dummy mines may have booby traps attached.

21. Types of mines.—Up to the present, German mines encountered belong to one of the following groups:

- a. Light antitank mines.
- b. Heavy antitank mines.
- c. Railway mines.
- d Light antipersonnel mines.
- e. Improvised mines.
- f. Elementary booby traps.

SECTION II

STANDARD FIRING DEVICES (IGNITERS)

	Paragraph
General.....	22
Friction igniter Zdschn. Anz. 29.....	23
Friction igniter with delay pellet B. Z. E.....	24
Friction igniter with delay pellets B. Z. 24 and Nb B. Z. 38.....	25
Pull igniter Z. Z. 35 (mechanical).....	26
Pull and tension wire igniter Z. U. Z. Z. 35.....	27
Pressure igniter D. Z. 35.....	28
Pressure igniter S. Mi. Z. 35.....	29
Combined igniter Z. D. Z. 29.....	30
Pressure igniter T. Mi. Z. 35.....	31
Push igniter, 1942 pattern, model Reinhard.....	32

22. General.—Unlike the British practice of using a special type of firing device for each type of mine, the Germans employ several types of standard firing devices with standard or improvised antitank and antipersonnel mines and booby traps. However, a special type of igniter is used with the Tellermine.

23. Friction igniter Zdschn. Anz. 29 (fig. 2).—*a. Description.*—This German igniter is normally used to ignite a fuze or detonator, which in turn is used to fire or ignite Tellermines, smoke candles, or prepared charges. When prepared for use, the igniter is screwed into one end of a short metal connecting tube, into the opposite end of which is pressed the safety fuze or detonator. The body (1) of the igniter is usually made of brass and contains a copper capsule (2) closed by a copper cap (3). A friction pull wire (4) passes through the capsule, which contains a friction composition. The friction wire is tightly coiled at one end (lower end in the illustration) and is attached to a hook (5) at the other end. The coiled end of the wire forms a resistance to pulling. The hook is soldered

or otherwise firmly fixed into a slot in the cover (6). To aline the split ring (7) and the hook (8), and to resist rotational or other minor movements of the friction wire, the cover is deeply crimped into a recess provided in the body of the igniter. The safety split ring (7) is secured to the body by a curved brass safety clip (8). A protecting cap (9) screwed onto the threaded end of the body provides protection to the igniter when not in use.

b. Employment.—This igniter is known to be used with the following:

(1) *Smoke candle No. K. S.*—This smoke candle is commonly used to produce a smoke screen for tanks. When the igniter is used to set off this type of candle, the safety ring of the igniter is attached by means of a cord or wire to the tank so that when the smoke candle is tossed out of the tank the igniter is fired automatically.

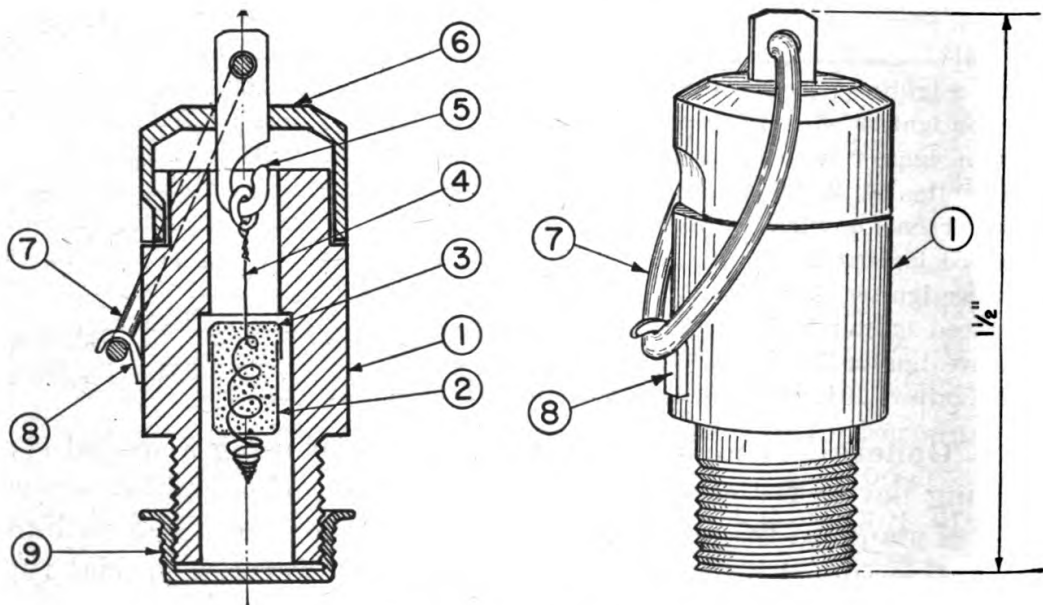

FIGURE 2.—Friction igniter Zdschn. Anz. 29.

(2) *Tellermines.*—This igniter is often used as a secondary firing device for Tellermines. A prepared detonator which screws into the base of the mine is connected to the igniter by a fuze about 2½ inches long. To ignite the Tellermine, the safety ring of the igniter is pegged to the ground below the mine so that when the mine is lifted or displaced, the mine is actuated.

(3) *Three kg prepared charge.*—When used as the igniter for the 3-kilogram prepared charge (TNT), the igniter is fastened by means of a connecting tube to a fuze which is attached to the charge.

c. Operation.—A pull on a trip wire (not shown) attached to the safety ring separates the cap and hook from the body, thus drawing

the friction wire through the friction composition, which action ignites the friction composition and in turn the attached fuze or detonator.

d. To neutralize.—This type of friction igniter is safe to handle as found, provided the cap or the ring is not pulled so as to draw the wire through the friction composition. If the safety ring is free of the clip, the ring and the cover should be fastened to the body by a piece of friction or adhesive tape to prevent movement of the wire. If the safety ring is secured to the body the igniter may be unscrewed from the tube joining it to the fuze or detonator.

24. Friction igniter with delay pellet B. Z. E. (fig. 3).—a.
Description.—This German igniter is generally used with the “message box” smoke flare and the “egg” and “shaving stick” grenades shown in figure 4. The short body (1) of this igniter is usually made of brass and contains a friction composition in which a friction pull

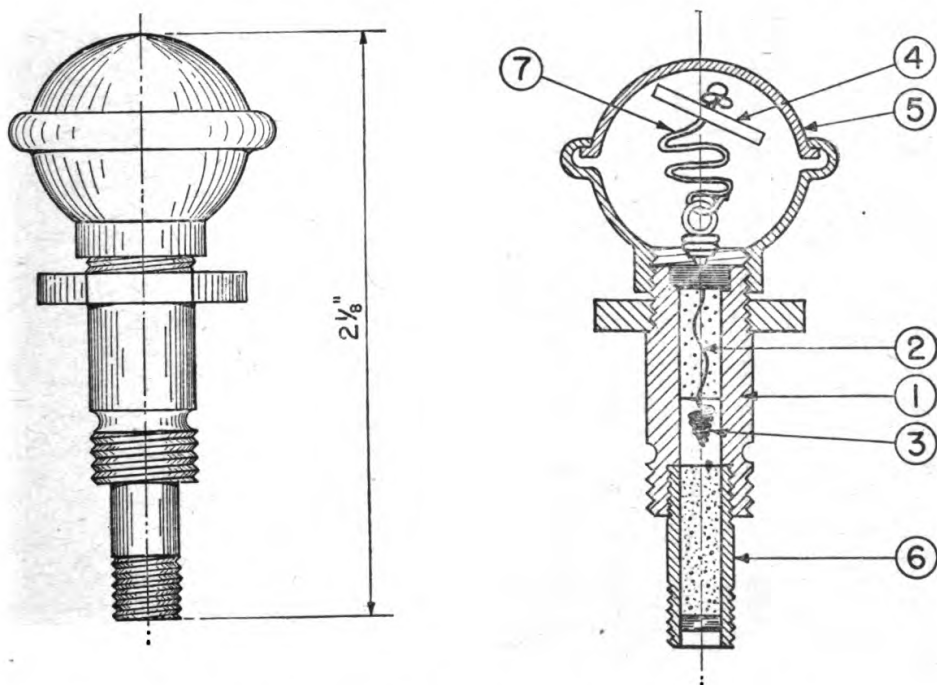

FIGURE 3.—Friction igniter with delay pellet B. Z. E.

wire (2) is cast. The lower end of the friction wire is coiled (3) to provide resistance which serves to ignite the friction composition when the wire is drawn through it. The upper end of the friction wire has a loop to which is fastened one end of a cord (7) about $2\frac{1}{4}$ inches long. The free end of the cord is attached to a disc (4) which is within the head (5). The steel tube (6) attached to the body contains a “delay pellet” of compressed powder, which in turn serves to ignite a fuze or detonator.

b. Employment.—When used with the “egg” grenade, the igniter head under present practice is colored blue and the body is fitted with a $4\frac{1}{4}$ -second delay pellet in the tube. When used with the “shaving stick” grenade and the “message box” smoke flare, the igniter head at present is colored red and the body is fitted with a 1-second delay pellet in the tube.

c. Operations.—When the head is unscrewed and the cord is pulled out, the friction wire ignites the friction composition and this in turn ignites the compressed powder delay pellet in the steel tube. When the delay pellet burns through, it ignites the attached fuze or detonator.

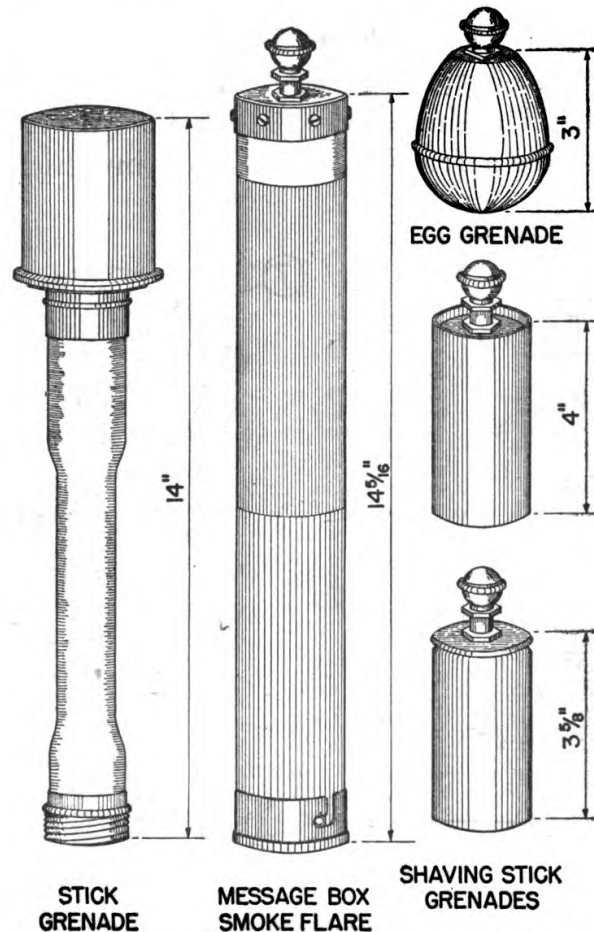

FIGURE 4.—Examples of use of friction igniters with delay pellets.

d. To neutralize.—If the igniter is found with the head screwed to the body, as shown in figure 3, the firing device is safe to handle without further manipulation. To render the igniter inoperative, the head should be unscrewed from the body, taking care not to exert any pull on the cord, and the cord cut close to the friction wire and the head replaced to protect the friction compound against ignition.

25. Friction igniter with delay pellets B. Z. 24 and Nb B. Z. 38 (fig. 5).—*a. Description.*—This German friction igniter is used gen-

erally to ignite grenades through a fuze or detonator. It consists of a lead tube or sheath (1) connected to a threaded brass fitting (2) by a short steel tube (3). The steel tube is threaded on both ends and contains the powder delay pellet (4). The lead tube contains the copper capsule (5) which holds the friction composition. The friction wire (6) is cast in the friction composition contained in the capsule. The friction wire is coiled at (7) to provide resistance to pulling and is joined to the "pull" loop (9) at its opposite end. The pull loop extends through the lead tube, which is flattened or pressed together at the upper end, thus preventing the loop and the friction wire from being freely or inadvertently withdrawn. The flattening of the tube also serves to close off the chamber containing the capsule.

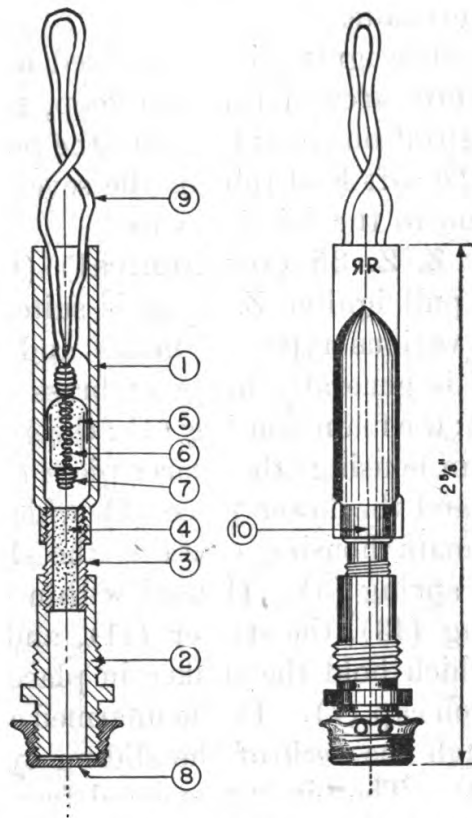

FIGURE 5.—Friction igniters with delay pellets B. Z. 24 and Nb. B. Z. 38.

The cap (8) which protects the delay pellet must be removed before the igniter is attached to a fuze or detonator. It is understood that the band (10) is colored, to identify the type of delay pellet contained in the igniter.

b. Employment.—This igniter is generally used with the German "stick" grenade (fig. 4), and it is understood it is also used with the smoke grenade (not shown). When used with the stick grenade, the entire igniter is screwed into the head end of the handle by means of

the threads on fitting. The loop is attached to the trip cord in the handle of the grenade. The igniter is probably installed in a similar manner in the smoke grenade.

c. Operation.—When the loop is pulled, it frees itself from the soft lead tube, drawing the friction wire through the friction composition contained in the capsule. The resulting flame ignites the delay pellet. When the delay pellet burns through, it ignites a fuze or a detonator attached to the fitting. The pellet used with the stick grenade has a delay of $4\frac{1}{2}$ seconds. It is believed that the igniter used with the stick grenade is marked B. Z. 24. Mention is made in reports on hand that the igniter used with the smoke grenade is marked Nb B. Z. 38. Also, mention is made that the latter has a white band (10); no mention is made, however, of such a colored band for the igniter when used with the stick grenade.

d. To neutralize.—The igniter is neutralized when the lead tube is pressed together firmly around the pull loop, to prevent its being pulled. Safe neutralization should require the pull loop's being completely enclosed in the soft lead tube or the severing of the pull loop close to its connection to the friction wire.

26. Pull igniter Z. Z. 35 (mechanical) (fig. 6).—*a. Description.*—The German pull igniter Z. Z. 35 is suited for use with trip wires in operating various types of mines and booby traps. The body of the igniter is generally made of brass and consists of the following four parts: the main housing (1); the guide piece (4) which is screwed to the main housing; the spacer piece (5) which is screwed to the guide piece; and the lower piece (6) which is screwed to the spacer piece. The main housing contains the sliding cylinder (2) and the compression spring (3). Housed within the sliding cylinder are the striker spring (13), the striker (11), and the two opposing locking pins (12) which hold the striker in place. The lower piece contains the percussion cap (7). In the unarmed condition, the safety pin (8) passes through the neck of the sliding cylinder (2) and the holes in the collar (9). The pin is prevented from falling out by the nut (15), and by the clip (10) which clamps around the collar.

b. Employment.—This igniter is known to be used with trip wires to operate the antipersonnel bounding mine, improvised mines, booby traps made up of prepared charges, and also as a secondary igniter for Tellermines. It is also used to actuate the heavy antitank mines when the lid is lifted or disturbed.

c. Operation.—To arm this igniter, remove the nut from the safety pin. After the nut is removed, the clip will still hold the safety pin in the hole (14) until it is pulled out by a direct pull on the ring (16) attached to the safety pin or from a distance by a cord or

wire attached to the ring. In the armed position the safety pin will have been removed; the striker is then held in position by the two locking pins which project into the groove behind the head of the striker. The compression spring controls the amount of force required to pull the sliding cylinder outward. When a pull, as from a trip cord attached at (17), moves the cylinder outward a distance of approximately $\frac{3}{16}$ inch, the pins move to a position opposite the open space above part (4) and are forced outward by the beveled shoulders on the striker just above the pins. When the pins move outwardly, the striker is in the released position and the striker

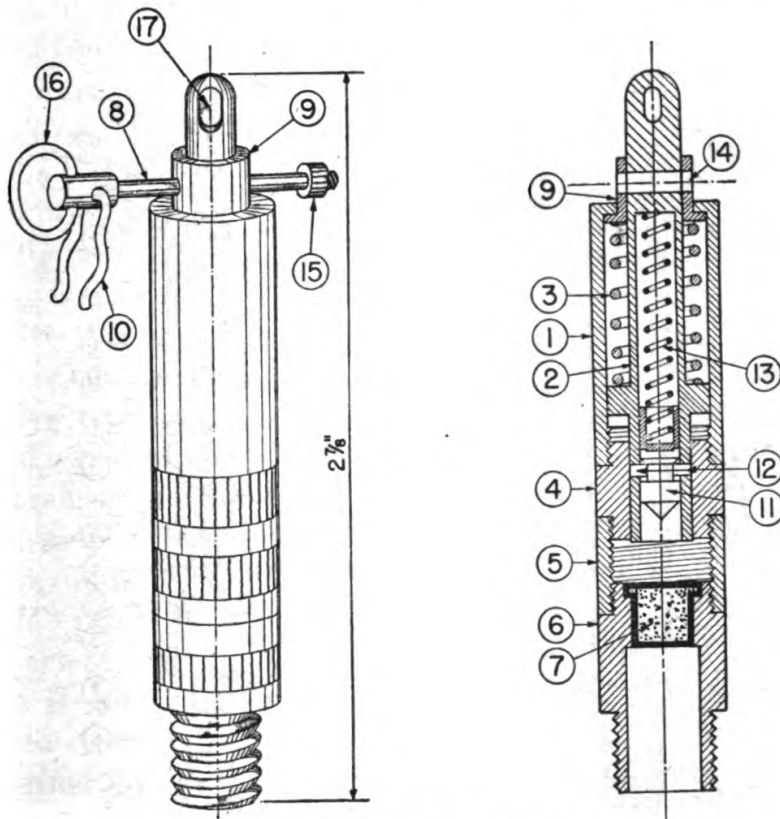

FIGURE 6.—Pull igniter Z. Z. 35.

spring, which is under compression, forces the striker to penetrate and ignite the percussion cap.

d. To neutralize.—The igniter is made safe by pushing a nail or a similarly shaped device through the hole (14) to prevent movement of the sliding cylinder which would actuate the striker. The trip wire attached to the igniter at (17) may then be cut.

27. Pull and tension wire igniter Z. U. Z. Z. 35 (fig. 7).—a. Description.—This type of igniter is generally used with mines and prepared charges which are actuated by wires in tension. The body of the igniter consists of four parts: the main housing (1), the guide piece (4), the spacer piece (5), and the lower piece (6). The main

housing contains the sliding cylinder (2) and the compression spring (3). The lower piece contains the percussion cap (7). Housed within the sliding cylinder are the striker spring (8), the striker (9), and the two opposing pins (10) which hold the striker in place. At the top of the sliding cylinder is a hole (11), through which a trip wire is securely tied. The collar (12) has two diametrically opposite slotted openings (13), having a clearance of $\frac{1}{32}$ inch for the free movement of the safety pin (14). The safety pin has a nut (15) at one end. When in a "safe" position the safety pin is inserted far enough through the hole (13) to permit the shoulder (16) on the safety pin to fit in the recess or groove (17) provided on the

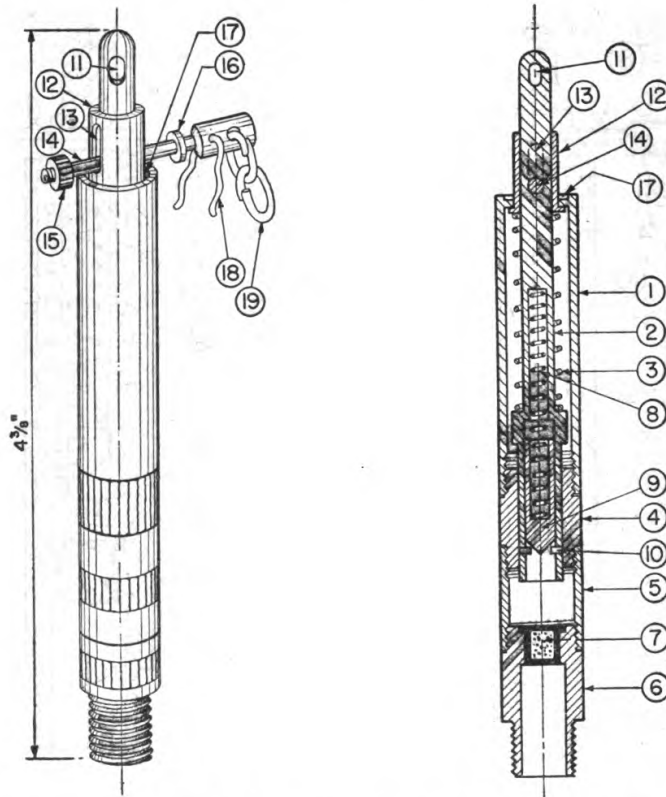

FIGURE 7.—Pull and tension wire igniter Z. U. Z. 35.

upper end of the housing, and the clip (18) is fitted around the collar. With the safety pin, the nut, and the clip in the position described, the igniter cannot be fired, since any pull of a cord attached to the ring (19) will cause the loose link ring to open and the cord to become detached.

b. Employment.—This igniter is designed for use with explosive devices which are actuated by trip wires under tension and is used mainly in places where the trip wires can be easily concealed. Hence it is frequently employed with mines and prepared charges in barri-

cares, street barriers, etc. When the igniter is in position, that is, when it is attached to a mine or charge and the trip cord (in tension) is attached to the igniter by means of the hole (11), the movable parts are covered by a protective tube about twice the length of the igniter. This tube, made of some material similar to oilcloth, insures free movement of both the movable cylinder and the tension wire when the igniter is buried.

c. Operation.—The igniter is safe when the safety pin is at any position in the slot. The shoulder is disengaged from the recess where it is held by pressure of spring by raising the pin in the slot. The igniter may function if the hole for the pin passes in either direction beyond the limits of the slot. Before the igniter can function it must be armed by applying sufficient tension on the trip wire to pull out the sliding cylinder such an amount as to place the safety pin at approximately the center of the slotted holes. This position of the cylinder permits the easy withdrawal of the safety pin after the mine or charge is laid and the nut has been removed. The sliding cylinder should not be pulled out to bring the pin to bear against the upper face of the slots. The reason for this requirement is that it would not be possible to determine whether or not excessive tension existed in the trip wire; if sufficient excessive tension did exist, it would cause the cylinder to be withdrawn far enough to release the striker and to operate the igniter prematurely. Should the trip wire break while setting the igniter, the safety pin will return, under the pressure exerted by the compression spring, to its "safe" position, from which position it cannot be withdrawn. The final act in arming the igniter is the withdrawal of the safety pin. This is done by removing the nut, and then pulling the cord attached to the rings. When properly armed, the igniter can function either by pulling on the trip wire or by cutting it. When the trip wire (which is under the required initial tension) is pulled, the sliding cylinder moves outward, and when the pins reach the space above the guide piece they are forced out by the pressure of the striker spring on the striker. This action releases the striker and under the action of the spring the striker penetrates and fires the percussion cap. If the tension trip wire is cut, the compression spring forces the sliding cylinder inward until the pins are forced into the space below the guide piece. The striker is then released and under the propulsion given to the striker by the striker spring, the striker penetrates and fires the percussion cap.

d. To neutralize.—If the safety pin is in position, make sure that it cannot slip out of the hole and thus unscrew the entire igniter from the mine or charge. If the safety pin has been previously re-

moved and the tension trip wire is intact, push a nail or a piece of metal of similar shape through the slotted holes and the hole provided for the safety pin in the striker and secure it by wire or other means to prevent movement of the sliding cylinder. Having done this, make sure that there is no igniter at the opposite end of the tension trip wire and then cut it. *Never cut the wire before neutralizing the igniter.*

28. Pressure igniter D. Z. 35 (fig. 8).—*a. Types.*—There are two types of this German igniter, one large and one small, both of which are for igniting mines through pressure applied to the igniter. Both are approximately $2\frac{3}{4}$ inches long. The large igniter has a body $1\frac{1}{4}$ inches in diameter, is made of aluminum, and is painted brown. The small igniter has a body 1 inch in diameter, is made of brass, and is unpainted.

b. Description.—(1) *Large type (fig. 8 (A)).*—The igniter body (1) houses a plunger assembly and has a base plug (2) containing a percussion cap (3). The plunger assembly consists of a movable cylindrical plunger (4) to which is screwed a pressure head (5), the top of which is adjustable in relation to the top of the plunger, and a striker (6). The plunger rides in the guide (7), and is held in position by the pressure spring (8). The lower part of plunger is bored to receive the striker assembly. The striker or firing pin is held in position within the plunger by the two steel balls (10) which seat in holes in the plunger. The safety device is the pin (11), with a nut (12). The pin fits into hole (13) and prevents the plunger from moving downward. To prevent the safety pin from accidentally falling out when the nut is off, a steel ball (14), under pressure from spring (15), fits into a groove in the safety pin. Pressure on the steel ball can be varied by means of the adjusting screw directly over it.

(2) *Small type (fig. 8 (B)).*—This type is similar to the large type except for two short pins (10), guide (7), and guide spacer (16). The pins have the same function as the steel balls (10) in the preceding description. The guide and guide spacer combined replace the longer guide found in the larger type. The pressure required to operate this igniter is much less than is required to operate the large type igniter described above.

c. Employment.—Both sizes of this type of igniter are used to fire prepared charges, particularly where pressure, such as from vehicles, can be easily applied (as in improvised road barriers). The larger type igniter (fig. 8 (A)) is also used as the main igniter in the heavy antitank mine. The small igniter (fig. 8 (B)) is known to be used in improvised mines made up from the heads of "stick" grenades.

d. Operation.—These igniters are armed by first removing the safety pin nut (12), and then withdrawing the safety pin (11). The igniters operate when pressure is applied on the pressure heads. Pressure transmitted by a vehicle or any other object imposing a load on the pressure head will actuate the igniter when it is armed. When used in connection with improvised road barriers, the pressure is usually transmitted through a plank to the pressure head. This use probably explains the form of pin. With pin in place, a plank or other weight could force the plunger down until stopped by pin striking the body. The pin could not then be withdrawn, as the shoulder on the pin would engage the shoulder of the body recess. Inability to withdraw the pin would serve as a warning that the

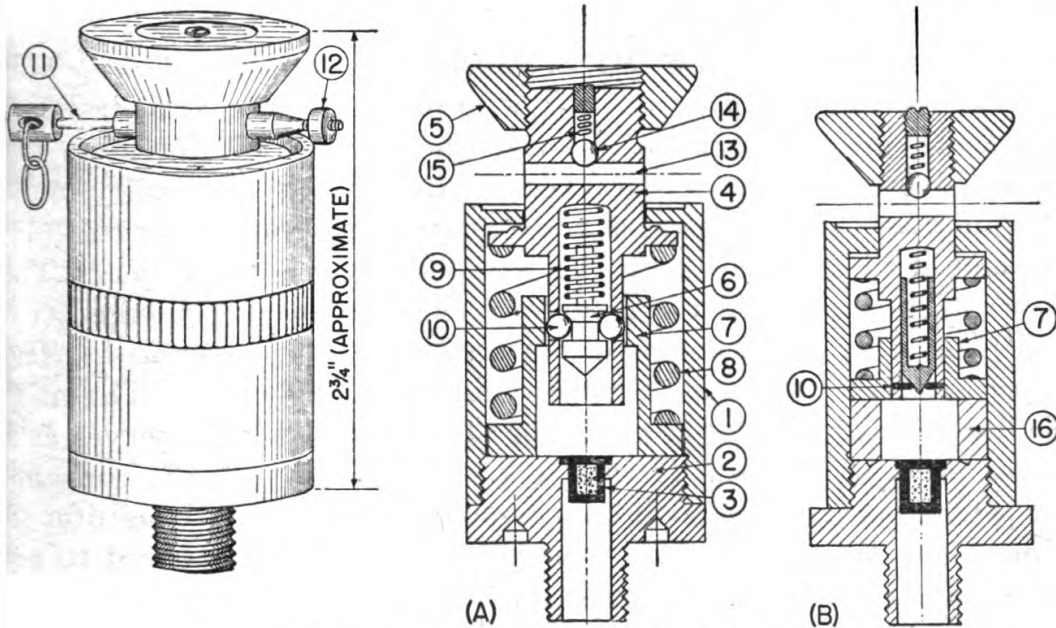

FIGURE 8.—Pressure igniter D. Z. 35.

weight on the plunger is excessive. The pressure head is adjustable by means of the screw threads, as may be noted in figure 8 by comparing the positions of the pressure heads (5) in (A) and (B) in relation to the top surface of the plunger (4). This adjustment provides a means of controlling the magnitude of load required to fire the igniter. The heavy antitank mine employs this adjustment feature in the following manner: One end of the lid of the mine is hinged and the other rests on a compression spring. The igniter is mounted alongside the compression spring under the mine lid. The pressure head of the igniter is adjusted to such an elevation that it will receive no load that may be applied on the lid of the mine until the compression spring has been compressed. By adjusting the elevation of the pressure head in respect to the underside of the mine lid,

-the degree of compression of the compression spring, and consequently the magnitude of load required to fire the igniter, can be varied. When enough pressure is applied to the pressure head to depress the plunger $\frac{1}{4}$ inch, the steel balls ((A) (10)) or pins ((B) (10)) will be freed of the guide shoulder and will be forced outward and downward, thus releasing the striker. The compressed striker spring (9) propels the striker downward, setting off the percussion cap.

e. To neutralize.—If the safety pin is in position, make sure that it cannot slip out of the hole and then unscrew the entire igniter from the mine or charge. If the safety pin has been previously removed, push a nail or a similarly shaped piece of metal through the safety pin hole and secure it by a wire or other means to prevent the plunger from being moved.

29. Pressure igniter S. Mi. Z. 35 (fig. 9).—*a. Description.*—This German pressure igniter is used with mines of the antipersonnel type which are buried in the ground; when so used the antennae (7) project above the surface. The body of the igniter is generally made of aluminum and consists of three parts: the upper housing (1), the middle or center housing (5), and the lower housing (3). The upper housing contains the pressure spring (2) and the plunger (6), which has three steel antennae (7) attached to its upper end. The upper housing also acts as an upper guide for the plunger. The middle housing acts as a lower guide for the plunger and also serves as a spacer between housings (1) and (3). The lower part (3) contains the percussion cap (4) and also is threaded for attaching the igniter to a mine assembly. The lower portion of the plunger is bored to receive the striker assembly, consisting of a striker (8), two steel balls (9), and the striker spring (10). The striker is held in position within the plunger by the steel balls (10) which seat in holes in the plunger walls and project into the groove above the pointed striker head. The upper end of the plunger is drilled (12) to receive the safety pin (11) which is fitted with a nut (15). The safety pin has a circumferential groove (not shown) to form a seat for the ball (14), which is pressed into this seat by the spring (13). Compression on the spring can be varied by means of the screw (16). The ball, seated in the groove in the safety pin, prevents the safety pin from accidentally falling out of the plunger when the nut is removed.

b. Employment.—This pressure igniter is normally used with the antipersonnel bounding mine when the latter is used as a pressure mine. The igniter is attached to the top of the mine which is buried in the ground so that the antennae of the igniter project slightly

above the surface. The antennae are then camouflaged by leaves or grass.

c. Operation.—The igniter is armed by removing the nut and withdrawing the safety pin. When pressure is applied to the antennae, which apparently are quite rigid, the plunger is forced down against the pressure of the spring. The plunger moves down until the steel balls are free of the shoulder at the upper end of the middle housing. This position of the plunger permits the steel balls to be forced out of the holes in the plunger because of the pressure exerted on

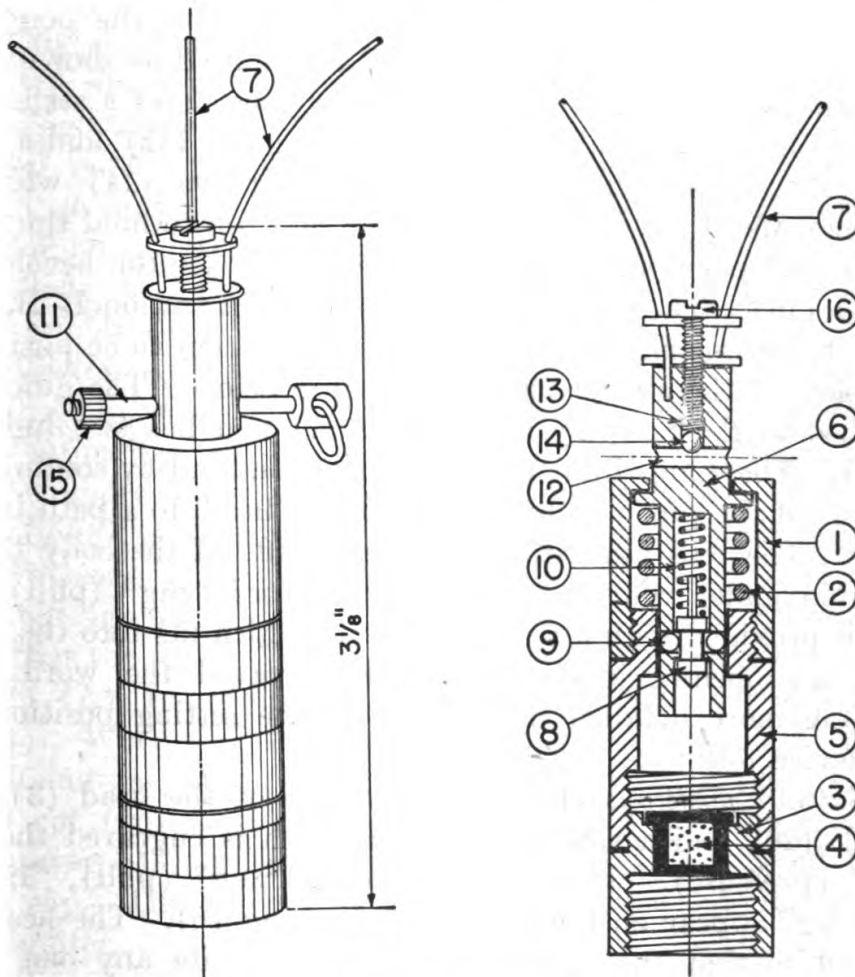

FIGURE 9.—Pressure igniter S. Mi. Z. 35.

them by the striker, which is, in turn, under pressure from the striker spring. The balls fall into the chamber below the shoulder of (5) and the striker is then released and is propelled downward by the striker spring, setting off the percussion cap.

d. To neutralize.—The igniter is neutralized by pushing a nail or similarly shaped piece of metal into the safety pin hole (12). Care should be taken in handling this igniter since an applied pressure of

about 15 pounds on the antennae or plunger may cause it to ignite. After neutralizing the igniter, it should be unscrewed from the mine.

30. Combined igniter Z. D. Z. 29 (figs. 10 and 11).—*a. Description.*—This German igniter is a firing device designed to function either as a pressure igniter or as a pull igniter. The igniter body (1) has a base plug (2) and a pressure head (3) and houses a striker assembly. The base plug is threaded for attaching the igniter to a detonator and it holds a percussion cap (4). To prevent the base plug from being unscrewed from the body, a set screw (5) is provided (see sec. A-A, fig. 10). The head has a free fit to permit its rotation in the bushing (6), which is fixed to the body by a threaded collar (7). A pin (8) is fixed to the head as shown in section B-B, figure 10. The striker assembly consists of a striker (9), two shear pins (10), a pull pin (11), a metal guide (12), and a helical spring (13). The striker has a circular groove (14) which receives the ends of the shear pins and the pull pin to hold the striker in the cocked position. Just above the groove are the beveled cuts (15) and (16). The cut is beveled as shown in section B-B, figure 10, so as to permit any pin under either beveled cut to be pushed out of the path of the striker as described in *c* below. The guide (12) is attached to the body by the screws (17) and has two lugs (18) and (19). These lugs limit the rotation of the head by confining the movement of the pin, which is a part of the head, to a path between the lugs. The pull pin extends to the outside of the body through an opening under which is engraved the word "zug" (pull). The igniter is provided with a safety key (24) which fits into the igniter through an opening under which is engraved the word "sich" (safe). A more detailed description of the setting positions and safety device follows:

(1) *Setting positions* (fig. 11).—The top of the head (3) has a cut-mark (20) and a slot (21) beside which is engraved the word "druck" (pressure). Three setting marks "zug" (pull), "125 kg," and "45 kg" appear on the top of the bushing (6). The head may be turned so that the mark (20) comes opposite any one of the three setting marks by using a coin or similar object in the slot (21). When the mark is opposite each setting mark, the pin (8) which protrudes slightly above the flange of the head fits into a small indentation (22) on the underside of the bushing. There are three of these indentations to correspond to the three setting positions. The striker (9) is engaged to the head by the pin (23) so that it will rotate with the head. As the head, together with the striker, is turned to each setting position, the pins (10) and the pull pin (11) ride in the groove (14) and take the positions shown in figure

11. In this manner one or both of the shear pins and the pull pin can be brought in position to hold the striker. If a pin is positioned in one of the beveled cuts (15) and (16), it is not effective to resist the downward movement of the striker.

(2) *Safety device.*—The safety key (24) is a strip of flexible metal which fits between the striker and the percussion cap. If the striker is accidentally released, a slot (26) in the safety key will intercept the striker. If this happens, the safety key cannot be withdrawn and the igniter will not function.

b. Employment.—This igniter is usually specified for use in the assembly of antitank, antivehicle, or antipersonnel mines. It may be used as a pressure igniter to operate at 275 pounds (125 kilograms) in antitank and antivehicle mines; it may be used as a pressure igniter to operate at 100 pounds (45 kilograms) in antipersonnel mines; or it may be used to operate as a pull igniter either in an antitank and antivehicle mine assembly or in an antipersonnel mine assembly. In one reference, it is stated that this igniter may be obsolescent. However, recent publications show many assemblies in which it is used.

c. Operation.—This igniter may be adjusted to operate under any of the three different settings described below. The igniter is armed first by adjusting the setting and then by removing the safety key from the igniter. A long wire or cord is attached to the loop on the safety key, and the safety key is pulled out from a safe distance.

(1) *Pressure igniter set to operate at 275 pounds (fig. 11 (A)).*—To set the igniter to fire at this pressure, turn the movable head (3) so that the mark (20) is opposite "125 kg." See section "C-C," figure 11 (A), for the position of the shear pins (10) and the pull pin (11). When the required load is applied, both shear pins are sheared and the pull pin is pushed outward as its end rides the beveled cut (16), thus releasing the striker (9). The compressed firing spring (13) drives the striker downward, setting off the percussion cap. The percussion cap shoots a flame out of the bottom of the igniter.

(2) *Pressure igniter set to operate at 100 pounds (fig. 11 (B)).*—To set the igniter to fire at this pressure, turn the movable head so that the mark (29) is opposite "45 kg." See section C-C, figure 11 (B), for this position of the shear pins and pull pin. Note that the setting pin (8) is now stopped by lug (18). When the required load is applied, one of the shear pins is sheared; the other shear pin and the pull pin are pushed outward as their ends ride the beveled cut (16). This releases the striker and causes the device to fire as previously described.

(3) *Pull igniter* (fig. 11 (C)).—To set igniter to fire as a pull igniter, turn movable head so that the mark (20) is opposite the word "zug." See section C-C, figure 11 (C), for this position of shear pins and pull pin, and note that the striker is now held only by the pull pin.

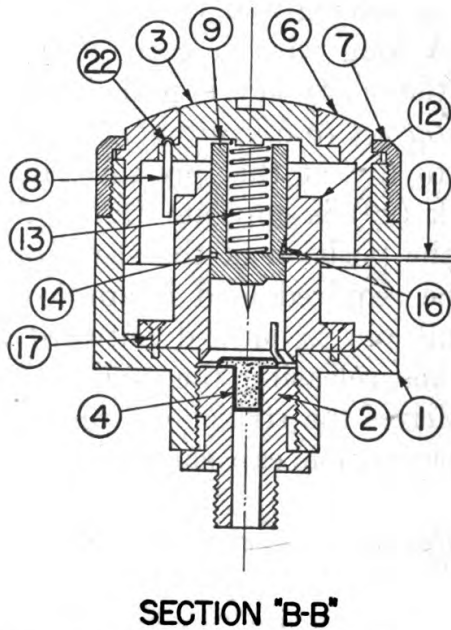
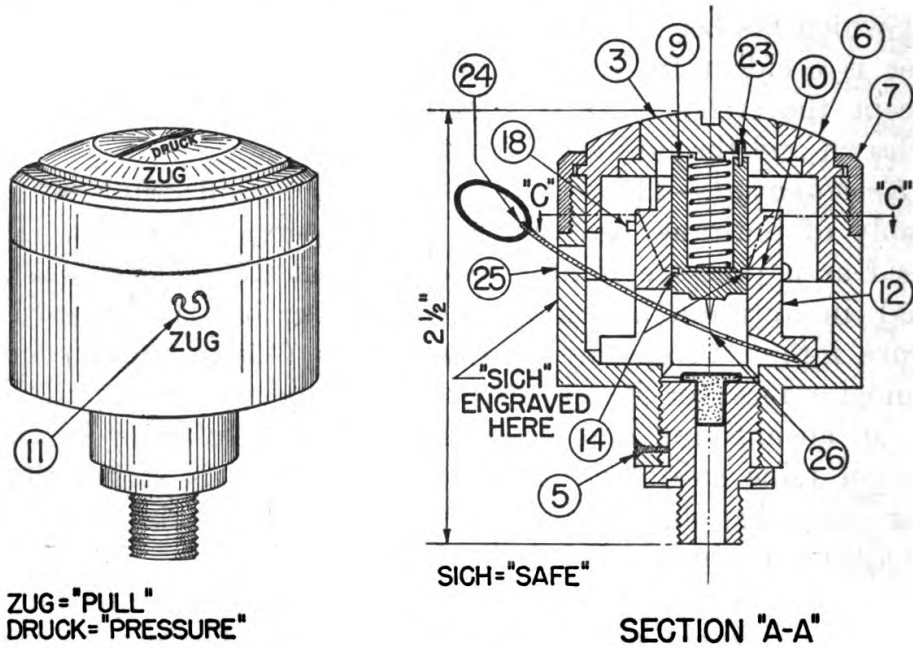

FIGURE 10.—Combined igniter Z. D. Z. 29.

Also note that setting pin is now stopped by the lug (19). When the pull pin is withdrawn by a trip wire, thus releasing the striker, the two shear pins are pushed outward as their ends ride in the beveled cuts (15) and (16); the firing is as described for the pressure igniters.

d. To neutralize.—The most effective method of neutralizing this igniter is to turn the head to the “125 kg” setting. This setting locks the striker pin with the two shear pins (see fig. 11 (A)). Then remove the detonator from the igniter, after unscrewing them as a unit from the mine. The cap (4) can be extracted by unscrewing the base plug (2) from the igniter body (1) after removing the set screw (5). When the igniter is set as a pressure igniter and the pull pin is missing, do not insert a nail in the opening marked “zug,” because it would fit into the beveled cut (16) and would not restrain the striker. Do not insert an object through slot (25) marked “SICH” to replace the key (24). It is dangerous, because an edge may come in contact with the percussion cap (3), and cause it to explode. To use a nail or pen knife for this purpose would be serious.

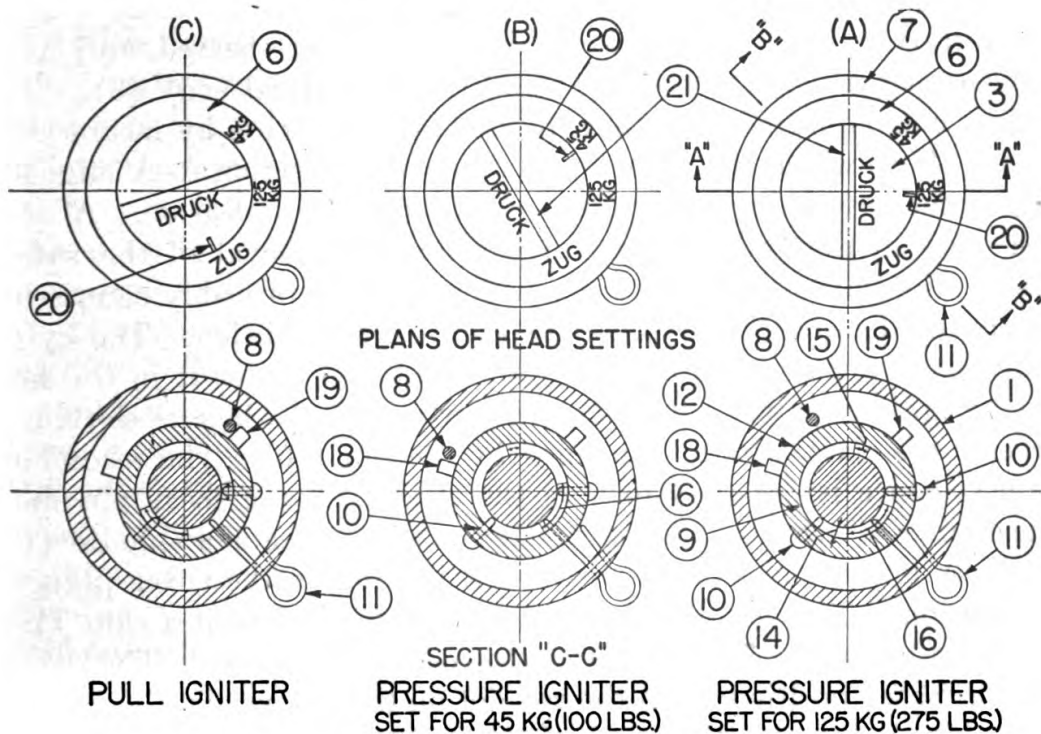

FIGURE 11.—Plans and sections of combined igniter Z. D. Z. 29.

31. Pressure igniter T. Mi. Z. 35 (figs. 12 and 13).—*a. Description.*—(1) According to available information this is the only type of main igniter used for the Tellermine, and, up to the present, it has not been found employed in other mines and booby traps. The body (1) is generally made of brass and houses a cylindrical-shaped assembly (3) which has a free fit in the igniter body. The collar (2) screws to the bottom of the body to hold the cylindrical assembly in place in the body. Clearance is provided so that the body and the internal cylindrical assembly can move vertically with respect to each other, except as prevented by the safety devices to be described later and

the shear pin (8). The internal cylindrical assembly consists of a body (3) which acts as a guide for the striker or firing pin (4) and a base plug (5), containing the percussion cap (6). When igniter safety devices are disengaged, the striker is held in a cocked position within the guide body (3) by the striker spring (7) under compression and the shear pin (8). A cover plate (9) is fastened by screws to the top of the igniter body (1) and contains a setting dial (10). The plan of the igniter (fig. 12) shows markings "SICHER" (safe), "SCHARF" (armed), and a red dot (11) on the setting dial. A white line appears under "SICHER" (safe) and a red line appears under "SCHARF" (armed). A slot is provided on the setting dial to permit turning.

(2) The igniter has two safety devices. The main safety device consists of a safety bolt (12) which passes through a slotted hole (13) in the striker and prevents full movement of the striker pin if, for instance, the shear pin should be damaged or sheared, and locks movement between the body (1) and the cylindrical body (3). The safety bolt is moved in or out of the "safe" position by means of a claw (14) to which is attached a flexible wire. Section A-A (fig. 13) shows the safety bolt in extreme "out" (unsafe) position. A stop pin (15) in the body prevents the complete removal of the safety bolt. The claw and wire are removable and will probably be missing in captured mines when found in the armed condition. The cylindrical bolt (12) is designed with a shoulder to center it in the hole in the igniter body. The enlarged portion of the bolt is slotted to receive the claw, which is engaged by the pin (16). The secondary safety device is designed to hold the striker off the shear pin until the igniter is armed. This secondary safety device is a spindle (17) with its upper end secured to the setting dial in the cover plate of the igniter. The spindle's lower end has attached to it a cam (18). The cam is equivalent to a 130° sector of a spiral ramp. The device is in a "safe" position when the red dot on the setting dial is opposite the white line under the word "SICHER" (safe). In this position the cam fits underneath a notch (19) cut into the shoulder of the striker, as shown in section B-B, figure 13. The device is armed, except the bolt (12), by turning the setting dial counterclockwise until the red spot is opposite the red line under "SCHARF" (armed). This operation rotates cam to clear the notch (19) of the striker, thus releasing the striker until it is supported only by the shear pin. In this position the full compression of the spring (7) is resisted only by the shear pin.

b. Employment.—Apparently this igniter is used as the main igniter in the Teller mine. Up to the present time no other use for this igniter is known.

c. Operation.—To arm this igniter, first turn the setting dial counterclockwise until the red spot is opposite the red line under “scharf” (armed), and then withdraw the safety bolt until it is latched by the stop pin. A coin or similar object may be used to turn the setting dial. In order to avoid excessive pressure on the head (9), a screw driver should not be used to set the dial. The slotted hole in the striker permits free movement of the bolt when it is withdrawn. In this position the igniter is ready to fire, since the cam has been cleared of the striker, and the bolt is entirely free of striker and of the internal assembly contained in the body. Pressure exerted on the lid of the mine will move the igniter body downward with respect to the internal firing assembly. When the body reaches a point where the top of the striker has made contact with the adjusting screw (20), further downward movement will force the striker downward, thus shearing the shear pin. The compressed striker spring will then propel the striker downward, setting off the percussion cap. The percussion cap, when ignited, shoots a flame through the bottom of the igniter and ignites the detonator below.

d. To neutralize.—The neutralizing procedure for this igniter depends upon the condition of the mine in which it is installed. If the mine *has not been subjected to blast* or other disturbance, the igniter and its mine may be considered as “normal.” If the mine *has been subjected to blast* or other disturbance, the igniter and its mine must be regarded as “abnormal.” All Tellermines not found in their original carrying cases (see fig. 22) should be suspected of being “abnormal.” Field reports state that blast or other disturbance is very likely to damage or partially shear the shear pin. For this reason the Germans discourage the handling of Tellermines in which the igniters may be classed as “abnormal.” The igniter is neutralized and rendered safe when either one or both safety devices described above are in their “safe” position.

(1) *Igniter in mines NOT subjected to blast.*—Proceed to neutralize the igniter as follows:

(a) Turn the setting head clockwise from the “SCHARF” (armed) to the “SICHER” (safe) position with a coin or similar object inserted in the setting dial.

(b) If the claw is at hand, fit it into the safety bolt and press the bolt home until the assembly and the striker are latched to prevent their movement relative to body. Then wind the wire attached to the claw around the head of the igniter, to prevent any outward movement of the safety bolt. If the claw is not available, improvised means should be used to seat the safety bolt in its latching or locking position.

Caution: If any resistance is felt while turning the screw head it must

not be turned any further, as this might release the striker. The igniter (and its mine) must then be considered "abnormal."

(2) *Igniter in mines subjected to blast.*—If the mines are classed as "abnormal" but not sufficiently dangerous to require their detonation in place, they are to be neutralized. The procedure is as follows:

(a) Unscrew the igniter from the mine gently so that neither the igniter nor the mine cover is subjected to a downward pressure.

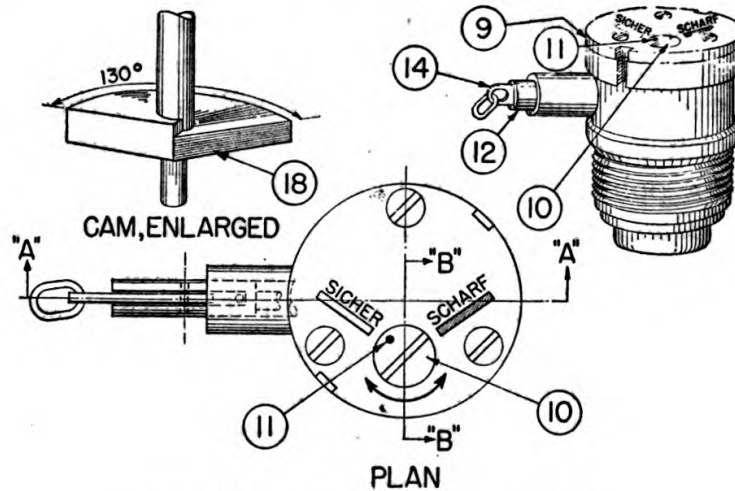

FIGURE 12.—Pressure igniter T. Mi. Z. 35.

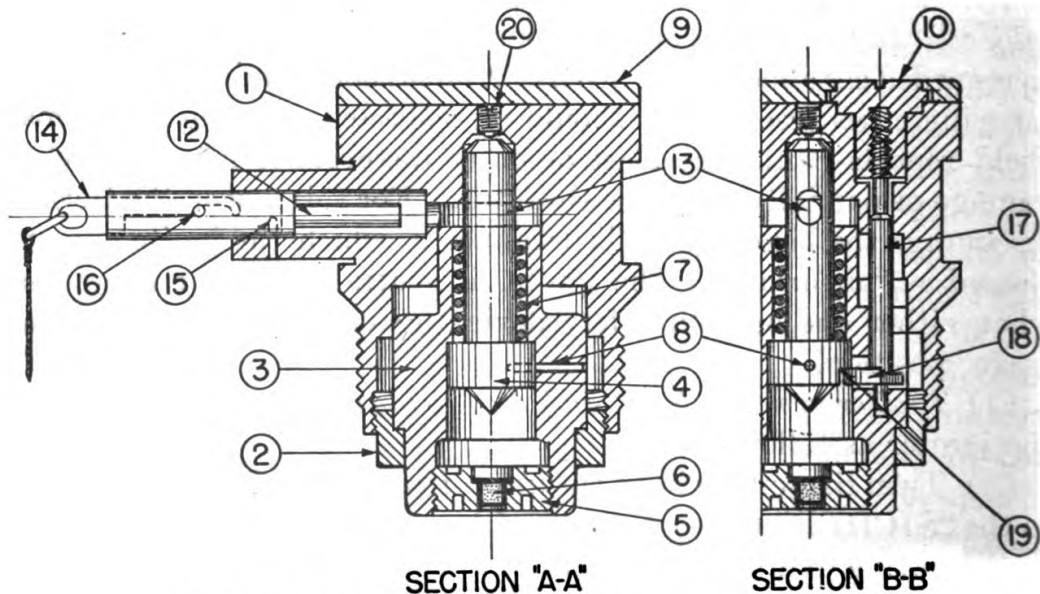

FIGURE 13.—Sections through pressure igniter T. Mi. Z. 35.

(b) Hold the igniter well clear of the mine and at a distance from the body, with the percussion cap end pointing away from the body. Turn the dial from "SCHARF" (armed) to "SICHER" (safe), if possible. If the shear pin is defective it is likely to shear and the striker will fire the percussion cap; it will then be impossible to push home the

safety bolt into the safe position. If the shear pin does not shear, press the safety bolt home as instructed for "normal" igniters. Replace the igniter in the mine to protect the detonator in the mine.

e. To rearm.—Under no circumstances should the igniter be rearmed without removing the igniter from the mine and testing the shear pin. Pull out the safety bolt and turn the dial to the armed position, holding the igniter as instructed in *d* (2) (*b*) above. If the igniter is "normal," neutralize as instructed in *d* (1) (*a*) above, and replace the igniter in the mine. This testing *must* be undertaken immediately before relaying the mine.

NOTE.—All of the instructions on neutralizing this igniter are very important and are based on British field experience and German documents.

32. Push igniter, 1942 pattern, model Reinhard (fig. 14).—This igniter is reported and described in the British "Royal Engineers Training Memorandum No. 3," issued November, 1942. In that memorandum it was stated that there was no evidence that this igniter had been adopted by the German Army, but that there was reason to suppose that it might be issued in the near future. This igniter is designed to supplant the standard pressure igniter D. Z. 35 (see par. 28), being simpler in design and construction, and with fewer parts.

a. Description.—The igniter body consists of two parts screwed together. The upper part (1) houses a plunger assembly, and the lower part (2) houses a percussion cap (3) and a No. 8 (German) detonator (4). The plunger assembly consists of a striker (5), a striker spring (6), a sleeve (7) which rides over the striker, and a plunger or pressure bolt (8). The striker is provided with a cylindrical hole (9), into which are inserted the turned-in ends of two metal arms (10). The turned-in ends of the arms pass through the slots (11) in the sleeve. The pressure bolt is held in position by a retaining cap (12), the construction of which is not definitely known. It is probable that the cap is removed when the igniter is placed in the mine.

b. Employment.—It is probable that this igniter is provided with standard (German) threading for use with all types of German mines and demolition charges.

c. Operation.—When pressure is applied to the pressure bolt, the sleeve moves downward and compresses the spring. When the shoulder of the pressure bolt reaches the turned-in ends of the arms it forces them outward and disengages them from the hole. The striker is thus released, and the compressed spring drives the striker onto the percussion cap. The percussion cap fires and ignites the detonator, which in turn fires the charge to which the igniter is attached.

d. Neutralization.—There is no known means of neutralizing the igniter prior to its removal from the mine or charge to which it is attached. Therefore, in removing the igniter, great care must be taken not to exert any pressure on the cap or the pressure bolt.

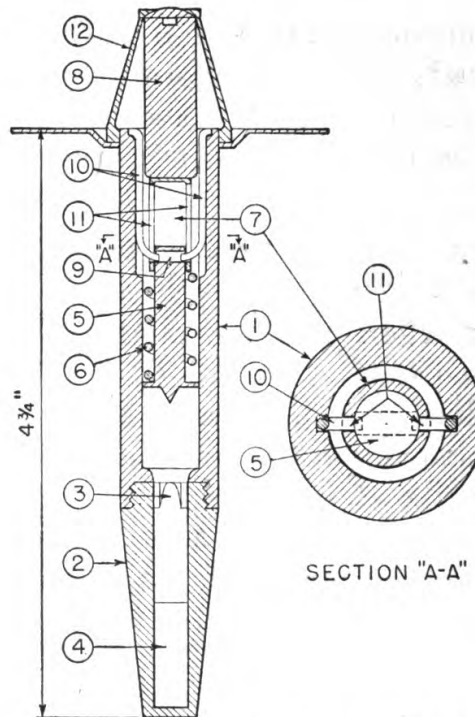

FIGURE 14.—Push igniter 1942 pattern, model Reinhard.

SECTION III

STANDARD DETONATORS

	Paragraph
General	33
Prepared nonelectric	34
Electric	35

33. General.—The Germans have developed several types of prepared detonators to be used with any of the prepared charges and with antitank mines, antipersonnel mines, booby traps, general mining, and demolition work.

34. Prepared nonelectric (fig. 15).—*a. Description.*—The detonator proper is inclosed in an aluminum tube (1) about 2½ inches long and ¼ inch in diameter. At its open end, the detonator tube is fitted into a larger tube (2). The safety fuze (3) enters the open end of the detonator tube as shown. A bakelite casing (4) encloses the junction of these parts. The bakelite casing has an aluminum-threaded fitting (5) at the lower end and at the upper end a bakelite cap (6) with a hole through which the fuze passes. The free end of the safety fuze is pressed into a short brass tube (7) which screws into the larger tube

(8). At its opposite end, the tube (8) is threaded to receive the igniter. As supplied for use, the igniter is not attached as part of the detonator mechanism, and the end of (8), designed to receive the igniter, is covered by a short brass screw cap (not shown) or by a paper cover. This detonator is used with the friction igniter Zdschn. Anz. 29 (see par. 23), which is the one usually employed to ignite safety fuzes. Detonators have been found in which the detonator tube is made of

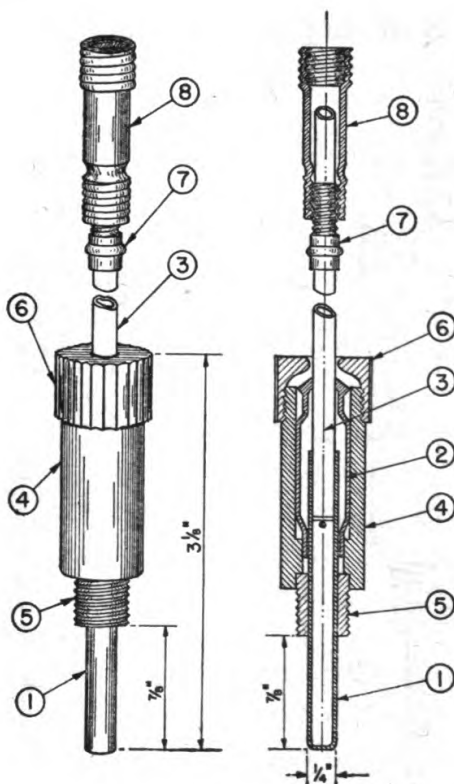

FIGURE 15.—Prepared nonelectric detonator.

copper, and bakelite casing is brass. In all other respects they resemble the type described.

b. Employment.—The threaded fitting (5) permits the detonator to be screwed into any of the prepared charges described in section IV of chapter 2. This detonator may also be screwed into the sockets of secondary firing devices found in antitank or antipersonnel mines.

35. Electric (fig. 16).—*a. Description.*—The electric detonator has much the same external appearance and is of the same general dimensions as the nonelectric detonator described above. It can readily be distinguished from the latter by the insulated wires (1) which pass through the head (2). One of these wires is 36 inches long and the other 39 inches long, and both are bared at the free ends. The wires are connected, in the detonator, to the firing bridge (3) and are insulated by the bitumastic material (4). The outer aluminum tube

(6), through which the wires pass, is sealed with a white sealing compound (5). The type recently captured has a length of approximately 3 inches over all with a 1-inch aluminum tube (7), containing the detonator, a black bakelite head (2), and wires (1) insulated with a black material.

b. Employment.—This detonator will fire with a current of approximately $\frac{3}{4}$ amperes at 3 volts. Types recently captured were fitted to German standard prepared charges. Other uses of this detonator are described in section IX of chapter 2 on "Improvised Mines."

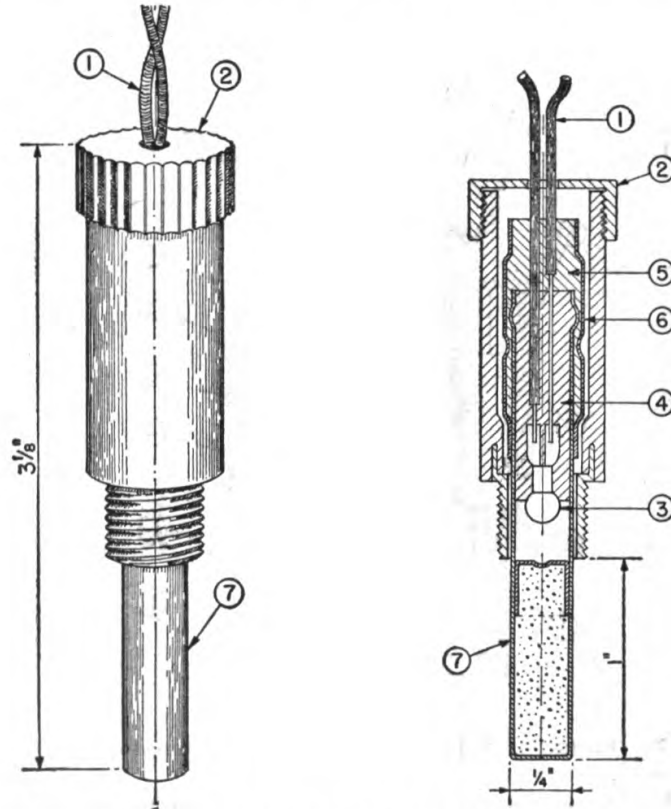

FIGURE 16.—Prepared electric detonator.

SECTION IV

PREPARED CHARGES

	Paragraph
General	36
Bore-hole charge model 28	37
Explosive charge model 28	38
Metal container HE (high explosive) charge, model 24	39
Three-kilogram HE (high explosive) charge	40
Ring charge for gun demolition	41
Demolition charges for armored structures	42

36. General.—The Germans have developed several types of prepared charges primarily for demolition work, but which are also used

in making up improvised mines and booby traps. They are all constructed with threaded metal receptacles to receive standard prepared detonators.

37. Bore-hole charge model 28 (fig. 17 (A)).—*a. Description.*—This is the smallest of the German prepared charges and is cylindrical in shape with an outer wrapping of varnished paper. It is about $1\frac{1}{4}$ inches in diameter, 4 inches long, and weighs about $\frac{1}{4}$ pound. The cylinder contains two cores of TNT, each 2 inches long. A threaded receptacle (1) to receive a detonator is located in one end.

b. Employment.—As the name implies, this charge is adaptable for use in bored or drilled holes.

38. Explosive charge model 28 (fig. 17 (B)).—*a. Description.*—This is a block-shaped charge resembling a large bar of soap. It has an outer wrapping of varnished paper and measures $1\frac{1}{2}$ by 2 by $2\frac{3}{4}$ inches, and weighs nearly $\frac{1}{2}$ pound. The explosive is either TNT or picric acid, and roughly corresponds to our $\frac{1}{2}$ -pound block of TNT. The threaded receptacle to receive the detonator is located in one of the large faces.

b. Employment.—This charge may be used singly or in multiple and in either case can be fired by a single detonator. This charge is suitable for any type of general demolition work and for use in improvised land mines.

39. Metal container HE (high explosive) charge, model 24 (fig. 17 (C)).—*a. Description.*—This German charge consists of a rectangular metal box approximately $2\frac{1}{4}$ by 3 by 8 inches, containing TNT. The total weight is about $2\frac{1}{4}$ pounds. The charge is provided with three threaded receptacles (1) to take the detonators. The shape of the charges facilitates their being grouped to form demolition charges of any desired weight.

b. Employment.—This charge is generally used for demolition work and is adaptable for use in improvised land mines.

40. Three-kilogram HE (high explosive) charge (fig. 17 (D)).—*a. Description.*—The charge consists of a rectangular metal box 3 by $6\frac{1}{4}$ by $7\frac{3}{4}$ inches. It contains TNT and weighs approximately $6\frac{1}{2}$ pounds. The charge is provided with a handle and three detonator receptacles (1), one of which is not shown in the figure.

b. Employment.—This charge is used singly or in multiple for heavy demolition work. It is also used in improvised mines.

41. Ring charge for gun demolition (fig. 18).—*a. Description.*—This German charge is shaped somewhat like a doughnut and comes in two sizes. The smaller size has an inside diameter of 4 inches and weighs about 3 pounds. The larger size has an inside diameter of $6\frac{3}{4}$ inches and weighs about 7 pounds. Both sizes contain

compressed TNT (5) encased in a sheet iron ring or body (1). The ring has a rib (2) and a detonator (3). In use, the detonator must point upward. The inside of the ring contains an air space (4) with a cross section shaped like a half circle.

b. Employment.—The small charge is used for the destruction of machine guns, mortars, etc. The larger size is used for the destruction

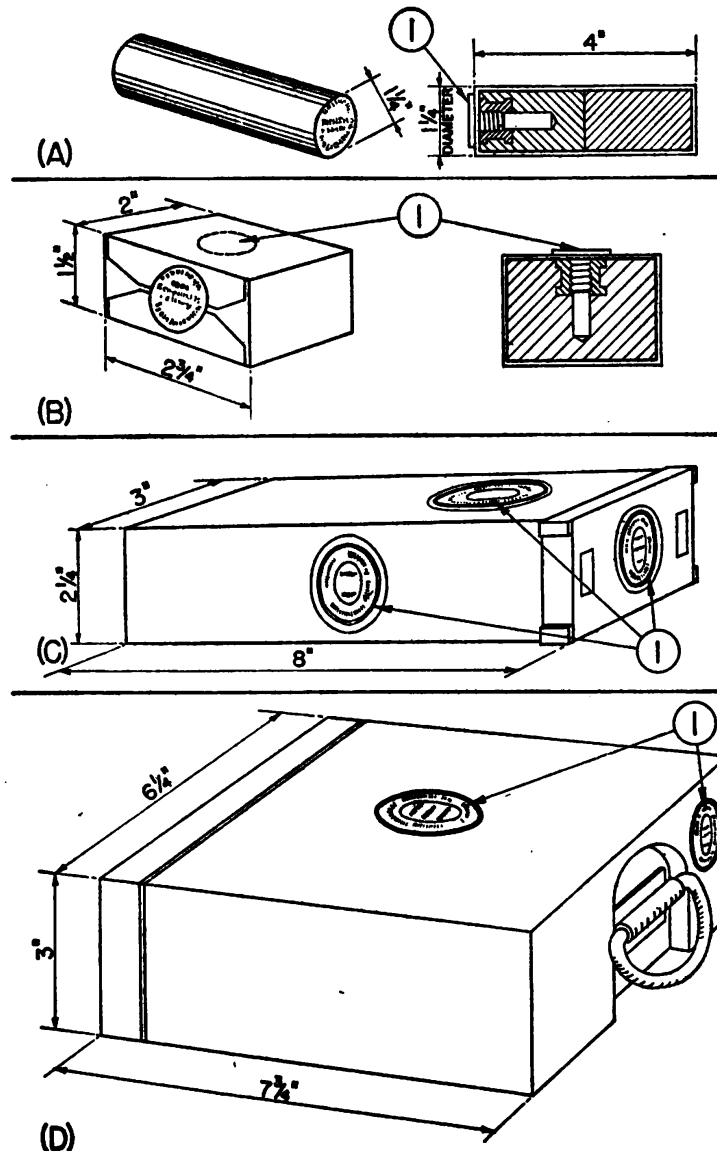

FIGURE 17.—Standard prepared explosive charges.

of larger caliber guns. The detonation of these charges renders the gun barrel incapable of use or repair.

c. Operation.—The charge is designed to slide along a gun barrel until it fits tightly. The purpose of the air space is to increase or concentrate the effect of the charge. A prepared detonator, with a length of safety fuze attached, and a friction igniter are generally

used to effect detonation. There is little fragmentation, but the blast effect on detonation is considerable. The gun barrel is compressed and distorted, and the area under the ring charge is so constricted that the barrel cannot be repaired.

42. Demolition charges for armored structures (fig. 19).—a.
Description.—There are two sizes of this type of German charge, described as follows:

(1) *Small type.*—The smaller charge (fig. 19 (A)), shaped like an old-fashioned tea kettle, is about 11 inches in diameter at the bottom, and is 8 inches high. It weighs about 27 pounds. The body (1) is made of sheet metal and contains TNT (5). A hemispherical depression (2) 5¼ inches in diameter is formed in the bottom to concentrate the explosion. The body is fitted with a handle (3) for carrying, and is provided with a detonator receptacle (4) in the top.

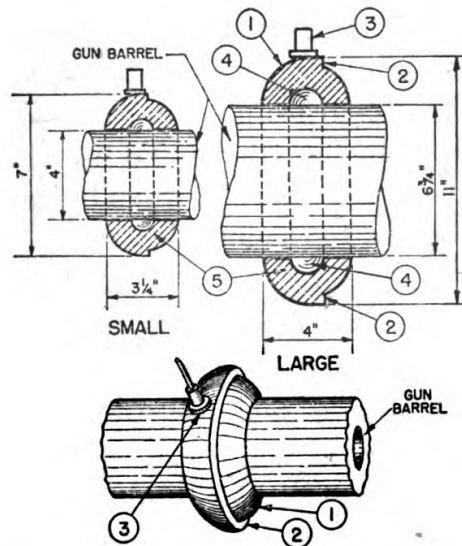

FIGURE 18.—Ring charge for gun demolition.

(2) *Large type.*—The larger size (fig. 19 (B)) has a flatter shape than the smaller type and consists of two sections to facilitate carrying and handling. Each part is dome shaped and is made of sheet iron (see (1) and (2)). Both bodies contain TNT and a complete charge of two sections weighs 110 pounds. The lower section or body (1) has a flat bottom with a diameter of about 20 inches. It is provided with a handle (3). A hemispherical depression (4) 8 inches in diameter is formed in the bottom to concentrate the explosion. A hole with a screw plug (5) is provided in body for filling the lower section with TNT. The upper section or body (2) has a concave bottom made to fit over the lower body. It is provided with a handle (6) and a detonator receptacle (7) in the top. The two sections are usually used together. Detonation is effected by the use of the pre-

pared detonator, which consists of an ordinary detonator with a length of safety fuze attached, and a friction igniter.

b. Employment.—These charges are designed to be placed on an armored tank, concrete fortification, or armored fortification, dome, or steel embrasure plate, and for other demolition work.

c. Operation.—The explosion punches a hole in the armor under the hemispherical cavity. The holes so created can then be used for the introduction of other offensive weapons. The resulting hole is usually about 4 inches in diameter on the side of the surface next to the charge, and up to 24 inches on the other side, depending on the thickness of the structure and the scabbing effects of the explosive. The material blown out is projected inside the structure with great force. The smaller charge (fig. 19 (A)) alone will penetrate steel armor up to $4\frac{2}{3}$ inches thick. The larger charge (fig. 19 (B)) will penetrate steel armor up to 10 inches thick. For greater penetration, two charges in succession laid on the same spot are required. The larger charge followed by the smaller charge will pierce steel armor up to 12 inches thick. Two large charges used in succession will penetrate armored surfaces up to 20 inches thick. To use them on vertical or inclined surfaces is difficult, but may be done by suspending the charges by means of ropes attached to the handles.

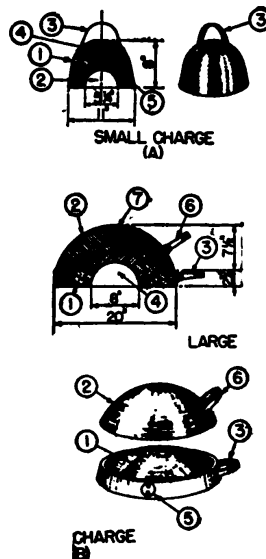

FIGURE 19.—Demolition charges for armored structures.

SECTION V

LIGHT ANTITANK MINES

	Paragraph
General	43
Tellermine or "T" mine.....	44
L. P. Z. antitank mine.....	45

43. General.—Up to the present, only two types of German light antitank mines have been encountered—the Tellermine or "T" mine and the L. P. Z. antitank mine. While there is much information available concerning the employment of the Tellermine in mine fields and road blocks, there is no information to date on the employment of the L. P. Z. antitank mine.

44. Tellermine or "T" mine (figs. 20 to 24, incl.).—*a. Description.*—(1) *General.*—The German Tellermine is the standard German antitank mine (1942). It is circular in plan with a diameter of $12\frac{3}{4}$ inches. It has a convex top, a flat bottom, and a maximum height of $3\frac{1}{4}$ inches. The total weight of the mine is $19\frac{1}{4}$ pounds. In a fully armed condition the mine is equipped with a main pressure igniter in the center of the top cover and one or two standard pull igniters in its base as secondary firing devices. The standard main igniter for the Tellermine is the pressure igniter T. Mi. Z. 35, described in paragraph 31. A sectional view of the mine is shown in figure 21. The body of the mine is a circular metal box (1) with a dome-shaped top surface containing 11 pounds of high-grade pressed TNT. A "floating" cover (2) is held down by a heavy metal ring (3) attached to the body and is supported in the center by a heavy spring (4). The spring fits into and bears on a metal fitting (5) which fits into the top of the body. The fitting also acts as a receiver for the detonator (6). Directly above the detonator are the two metal collars (7) and (8), which screw into a recess in the fitting, a compressible rubber ring (9), and the igniter (10). The lower collar (7) is a retaining collar for the detonator; the upper collar (8) is an adjusting or positioning collar for the igniter. The compressible rubber ring serves as a cushioned seat for the bottom of the igniter. The upper collar is screwed into the proper position in the fitting by means of a special tool. The small headless set screw (11) holds the collar (8) in position. The igniter is screwed into the mine cover (2) until it bears firmly on the rubber washer (12) and the rubber ring. The body of the mine has two receptacles (13) and (14), threaded to receive secondary firing devices. It also has a metal carrying handle (15). Receptacle (13) is usually located in the side of the body opposite the handle, and receptacle (14) is usually located in the bottom between

the handle and the center of the mine. Either pull friction igniter Z. Z. 35 (see par. 26) or Zdschn. Anz. 29 (see par. 23) with a detonator is used for secondary firing. A rubber strip (16) seals the junction between the cover and the body of the mine against the entry of water and dirt. The washer seals the joint between the igniter and the cover.

(2) *Carrying case* (fig. 22).—The mines are normally carried in a metal carrying case holding two mines complete with the igniters in place. The metal case is generally made of an aluminum alloy and has a weight of 13 pounds empty. A carrying case with two mines

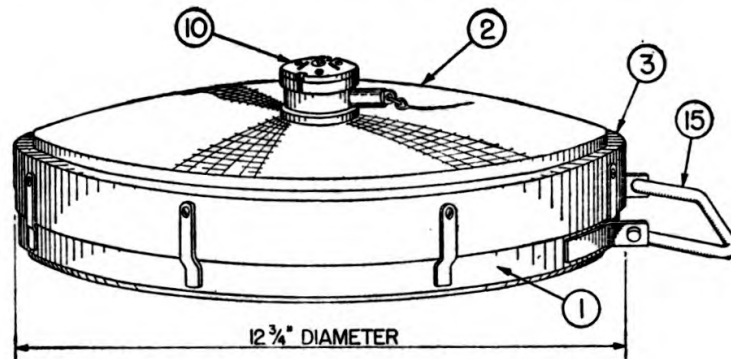

FIGURE 20.—Tellermine or "T" mine.

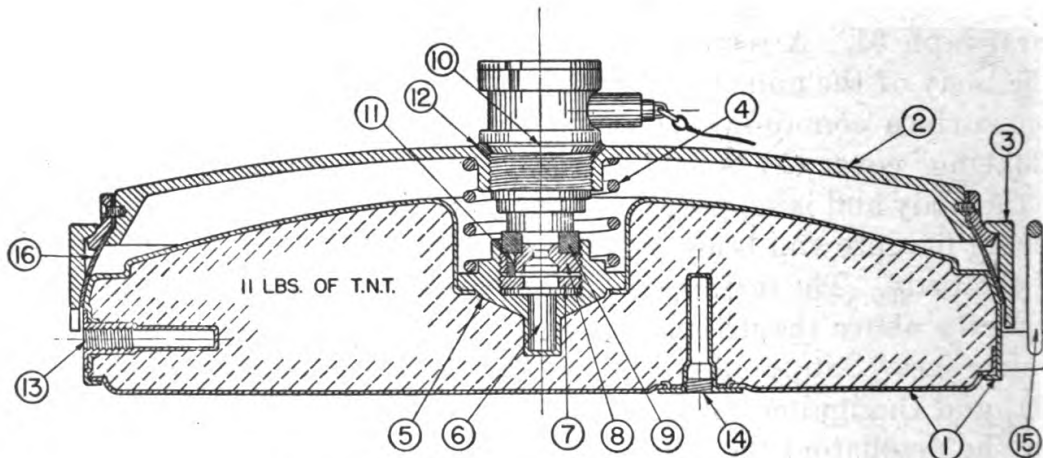

FIGURE 21.—Tellermine—sectional view.

weighs approximately 51 pounds. The case has a handle in its top. The side faces are hinged at the bottom to permit removal of the mines.

b. Employment.—(1) *General.*—Tellermines are normally used to form antitank mine fields. They may also be used in road blocks either in conjunction with artificial barriers or alone. Secondary firing devices may be inserted in the receptacles (13) and (14) and are intended to act as antilifting devices to explode the mine when lifted or moved from its buried position. Reports indicate that the British

have found at least one mine field in Libya in which every mine was equipped with secondary firing devices. In another report, many mines had pull igniters in the receptacle (14) only. In track blocks (see fig. 60), Tellermines were found laid one above the other, a foot or two apart, and inter-connected by a pull igniter. Tellermines also have been found laid upside down, thus making access to the igniter more difficult.

(2) *Road blocks.*—In road blocks, Tellermines have been found in both paved and unpaved roads. When used as road blocks, the in-

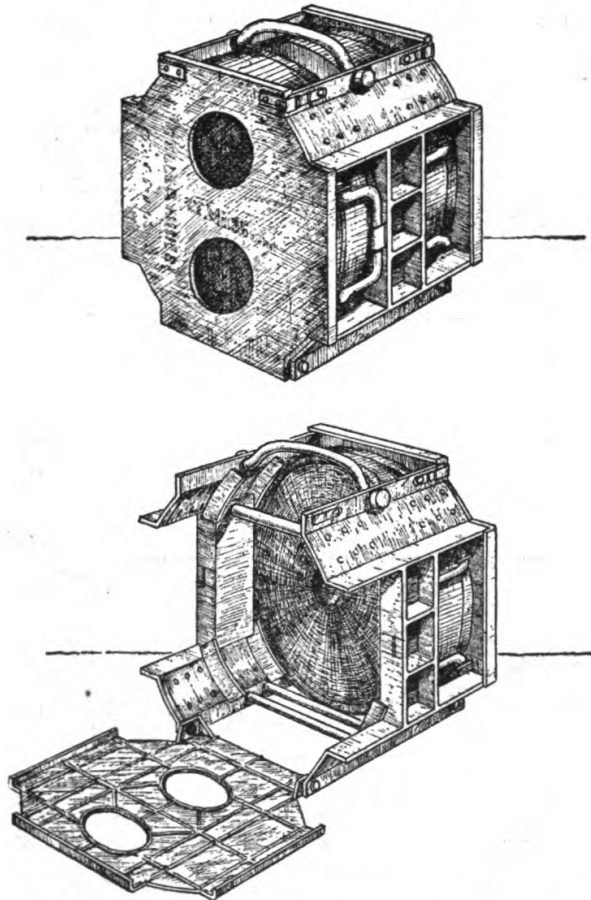

FIGURE 22.—Metal carrying case for Tellermines.

terval between mines normal to the road axis is about one pace and slightly less than this between rows. To make certain that the wheels of the vehicle will not pass between the mines without causing them to detonate, the mines are often interconnected by means of boards or bars laid over the firing devices of the mines. The Germans have developed a standard metal pressure bar for this purpose (fig. 24). The bar (17) is placed between two mines and has a circular collar (18) on each end. The collars are each split into two halves, which fit around the firing devices (10) and bear on the lid or cover of the

Tellermine. When the collar is placed on a mine, the detachable half of the collar is bolted to the fixed half. A chain (19) is attached to the loose half of the collar to prevent its getting lost. The number of mines connected by the bars may vary from two to six, according to the length of the barrier required.

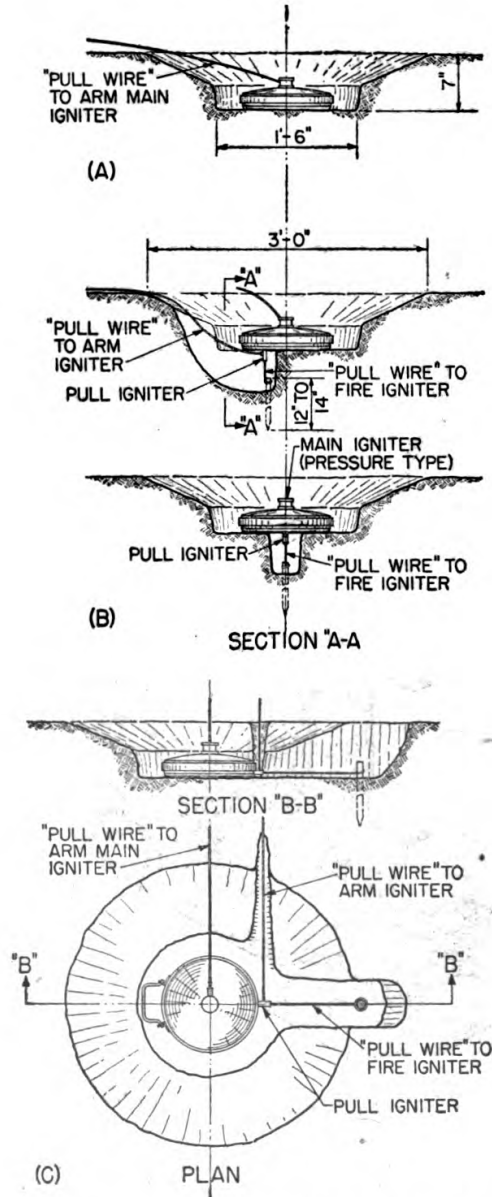

FIGURE 23.—Tellermine in place—sectional views showing antilifting devices.

(3) *Mine field installations.*—When laying the mine the excavation is tapered to prevent bridging action over the cover, which is generally placed between 3 and 4 inches below the ground or road surface. If the mine cover is less than 3 inches below the ground surface, sympathetic detonation may occur; and if more than 4 inches, the mines may not detonate under the calibrated pressure.

The spacing between mines is apparently quite important; German mine fields have been found with the mines spaced as close as 9 feet apart. With such spacing, sympathetic detonation invariably occurs, which, while not a vitiating factor in a road block, serves to render an extensive antitank mine field innocuous at the cost of only one tank to the attacking enemy. The usual spacing is from 15 to 30 feet. Where captured Tellermines are to be reused, the British recommend that they be spaced not closer than 20 feet.

c. Operation.—A total pressure of 250 to 300 pounds on the cover will detonate the mine by means of the main igniter (10). When a vehicle passes over the mine and applies pressure to the cover, the cover moves down against the compression of spring. Since the body of the main igniter is fixed to the cover, it will move downward, compressing

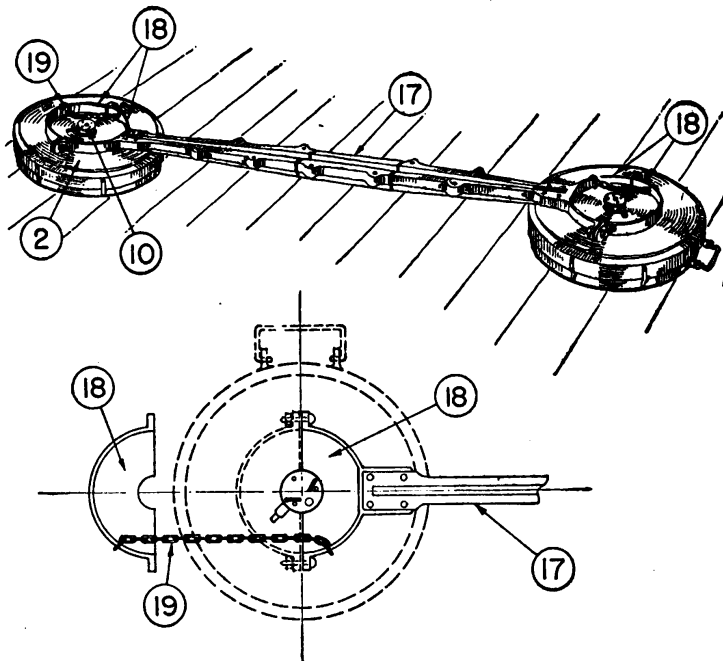

FIGURE 24.—Standard pressure bar for Tellermine.

the rubber washer (9). Continued downward movement of the cover forces the main igniter body downward with respect to the internal igniter assembly (see par. 31) until the igniter fires. The flame from the igniter sets off the detonator, which produces a small concussion. This small concussion, in turn, sets off the main charge of TNT in the base or body of the mine. The operation of the mine is effected by the position of the collar (8) in the body (5). If the collar is screwed beyond its correct position, a greater pressure on the mine cover is required to compress the spring sufficiently to cause the igniter to fire. Conversely, if the collar is screwed in short of its correct position, less pressure is required on the mine cover and the mine is relatively more sensitive.

d. To disarm.—Recent information from the field of operations emphasizes cautionary measures in the handling of Tellermines. Where mines are in areas that have been fought over, or have been subjected to blast, the shear pin (8) of the igniter (see fig. 13) is likely to be weakened. Therefore, in disarming a Tellermine, the steps to be taken are influenced by the conditions under which the mine is found or to which it has been subjected. Two main steps in disarming the mine are as follows:

(1) *Neutralize main igniter.*—After noting the condition to which the mine has been subjected, neutralize the main igniter or destroy the mine in accordance with the procedures below:

(a) *If mine is in "good condition" and has NOT been subjected to blast.*—Neutralize the main igniter, the T. Mi. Z. 35 igniter, as described in paragraph 31. Do not otherwise disturb the mine during this operation.

(b) *If mine HAS been subjected to blast, been fought over, or been out of our possession.*—Owing to the danger of a weakened shear pin which might break while neutralizing the igniter in the normal manner, the igniter must be removed from the Tellermine before being neutralized. If the shear pin is considered dangerously weak, destroy the mine. When the igniter has been made safe, it should be replaced in the mine to protect the exposed detonator, the adjusting collar (8), and the ring (9). Do not otherwise disturb the mine or any parts during this operation.

(2) *Neutralize and remove secondary igniters.*—After the main igniter has been neutralized, dig down beside the mine on the side opposite the handle to ascertain if there is an igniter in the receptacle (13) (see fig. 21). Then dig under the mine between the handle and the center of the mine to ascertain if there is an igniter in the receptacle (14). To facilitate this examination, the British use a small mirror 2 inches square fastened to a handle 9 inches long, which is both a life and time saver. If any secondary igniters are found, they should be neutralized before the mine is disturbed or lifted. Then secure a wire around the safety bolt of the igniter to prevent its coming loose, and remove the mine. Unscrew and remove the secondary igniters and their detonators from the mine. The mine is now disarmed except for the main igniter, which is neutralized, and the detonator. This constitutes disarming in the case of a Tellermine. The above instructions are based on British field experience, on captured German documents, and on observations of prisoners handling the mines.

NOTE.—The main igniter must not be removed from the mines except for the purpose of disarming as described in preceding paragraphs, or for the purpose

of testing the igniter as described under paragraph 31. The rubber ring, the collars, and the detonator should not be disturbed in the field because their installation is delicate. A special tool is required to install the collar. Improper installation will cause defective operation as described in *c* above.

e. Transportation or disposal of mines.—Disarmed mines in “good condition” should have the safety bolt of igniter secured in place by wire and should be packed in containers, preferably German containers (see fig. 22), to protect vulnerable parts from damage. Mines too dangerous to disarm and which are not destroyed in place, should have their secondary firing devices neutralized and should be blown up in dumps, removed from the minefield.

f. To arm.—Proceed in the following order:

(1) *Preliminary.*—Normally, the main igniter should be tested (see par. 31) before rearming for use against the enemy or for the purpose of inspection prior to re-issue of the captured mines.

(2) *Preparing main igniter.*—After the main igniter has been tested, the igniter should be neutralized in the manner prescribed in paragraph 31. After being neutralized, the igniter should be screwed into the mine, making sure that the rubber ring in the detonator assembly has not been withdrawn, and that the rubber washer under the shoulder of the igniter has not been displaced.

(3) *Laying mine.*—When it is contemplated to re-use a Teller mine against the enemy, the mine, with the main igniter and any secondary igniters attached and their safety devices engaged, should be placed in position in a hole with tapered sides. Figure 23 (A) shows the mine in place with only a main igniter. One method, that of placing the mine with a secondary firing device in the bottom of the mine, is shown in the two views of Figure 23 (B). For this condition, the hole is deepened and widened at one side to form a trench, and a stake is driven into the bottom of the hole. A short pull wire is then tied to the stake and to the igniter release pin. For placing a mine with a firing device in the side, the hole is trenched on the side opposite the handle and a stake is driven into the bottom of the excavation. A short pull wire is then tied to both the stake and the igniter release pin. (Other methods of placing these igniters may be devised). The wires from the safety pins of the secondary firing devices and the main igniter are led out to the side of the excavation. At this point, the main igniter may be armed by turning the setting head on the main igniter from “SICHER” to the “SCHARF” position. The pressure bars, if to be used, should then be set, and the mine covered and camouflaged as required. The safety device of the main igniter should then be removed by means of the wire attached to it. The safety devices of the secondary firing devices should then

be removed by means of the wires attached to them. The mine is now fully armed.

45. **L. P. Z. antitank mine** (figs. 25 and 26).—The British suggest that L. P. Z. may stand for “lange patrone zunder,” meaning “long cartridge fuze.” A wooden box containing five L. P. Z. antitank mines was captured from German parachute troops in the Suda Area of Crete in May 1941. To date, no other information has become available on these mines. It is probable that they were especially designed for use by parachute troops.

a. Description.—The L. P. Z. mine is a light antitank mine. It resembles a thick, large circular disc with flat top and bottom surfaces, and rounded sides. The mine measures 1 foot in diameter and is 5 inches thick. The housing of the mine is of sheet metal. It weighs 8 pounds and contains 5 pounds of TNT explosive. A more detailed description is as follows:

(1) *Main assembly* (fig. 25).—The body consists of two saucer-shaped pressed steel top and bottom covers (1) and (2). It contains the explosive body (3), a detonator assembly, and five igniter assemblies. The covers are held together by three bolts (4). The joint between the top and bottom covers is sealed with adhesive tape to make the mine waterproof. The explosive body is shaped and cored to take the detonator and igniter assemblies. The detonator (5) seats in a metal collar (6) which fits a molded recess in the top of the explosive body. A metal chamber (7) screws into the collar and receives a safety screw (8). The igniters are spaced radially (72° apart) around the mine. Each of the igniters is connected to the chamber by means of a horizontal brass flame tube (10) about $4\frac{1}{2}$ inches long. The British report that since the flame tube is unusually long, it is probable that a long cartridge fuze is contained in each flame tube.

(2) *Igniter* (fig. 26).—The igniters are of a push or pressure type and resemble the pressure igniter D. Z. 35 (see par. 28) in an inverted position. Each consists of the igniter tube or body (9), the plunger (13), and the striker mechanism contained within the plunger. The igniter body consists of three separate sections fitted together and fastened to the top cover by means of the bolt (11). A small internal collar containing the percussion cap (12) fits into the upper section of the body just below the flame tube. The middle section of the body serves as an upper guide for the plunger. The lower section of the body contains the compression spring (15) which acts as a spacer to restrain free movement between the plunger and the middle section of the body; it also acts as a lower guide for the plunger. The plunger is a single unit, the upper half of

which is hollow and houses the striker assembly. The middle section of the plunger is machined to serve as a shoulder for the compression spring. The lower section is threaded and is attached to the lower cover (2). The striker assembly consists of the striker (14), the striker spring (16), and two steel balls (17). The striker is in two parts and consists of a striker head and a cylinder into which the striker head is screwed. The striker cylinder contains the striker spring. The striker is held in a cocked position by means of the balls, which are retained in recesses in the upper section of the plunger and are partially seated in the head of the striker. The seat provided for the balls in the head of the striker is so formed that the balls receive lateral pressure from the striker, which is, in turn, under pressure from the striker spring.

(3) *Safety device* (fig. 25).—The L. P. Z. mine has only one safety device. It is the safety screw with an enlarged milled head which

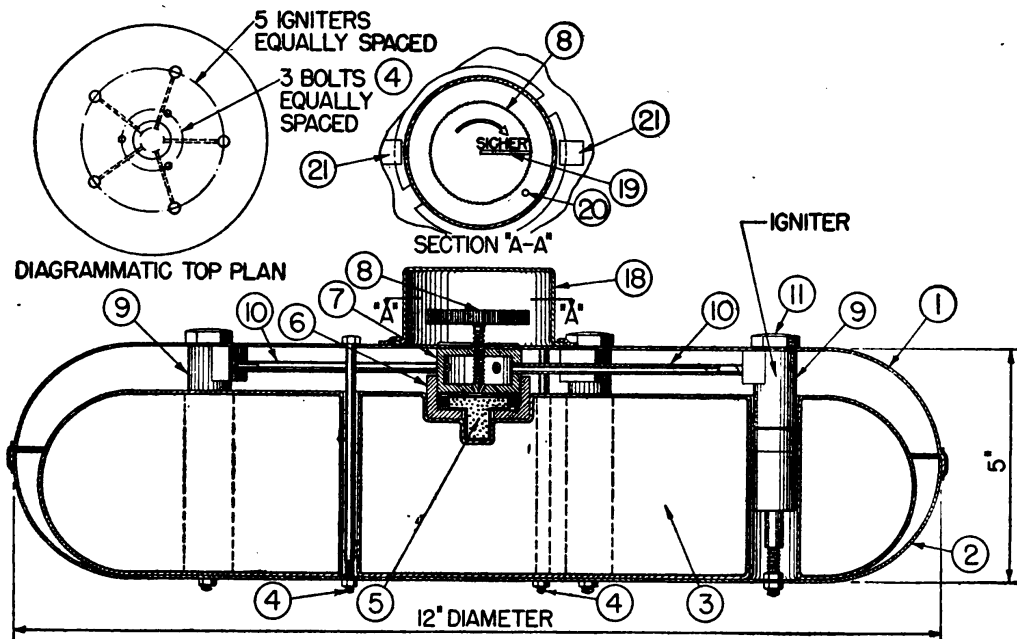

FIGURE 25.—L. P. Z. mine—sectional view.

is threaded in the top of the chamber. The screw is protected by a metal cap (18) which is fastened to the mine by two bayonet catches (21). The head of the screw has the word "SICHER" (safe) marked on it with an arrow pointing in a clockwise direction. A white radial line (19) also appears on the top of the screw head; a white spot (20) appears on the top of the mine under the cap. When the screw head is tightened in a clockwise direction until the white line on the head coincides with the white dot on the mine, the beveled lower end of the screw will have closed the beveled entrance to the detonator. With the screw in this position, the flame

from the igniters cannot reach the detonator, and the mine is safe. The screw is removed when the mine is laid and armed.

b. Operation.—(1) *Igniter.*—The operation of the igniter (see fig. 26) is explained as follows: When pressure is applied to the top of the mine by a passing tank or other vehicle, an outer portion of the flexible mine top cover (1) and the igniter body move downward together. Since the plunger is fixed to the bottom cover (2) of the mine, the downward movement of the igniter body serves to compress the spring. When the enlarged recess of the upper section of the body is opposite the steel balls, the balls are free to escape out-

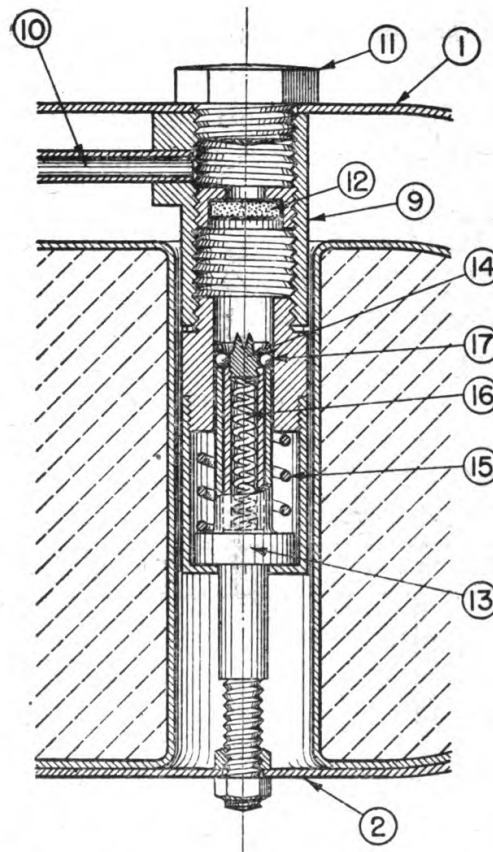

FIGURE 26.—Details of push-type igniter in L. P. Z. mine.

ward and thus release the striker, which is then propelled upward by pressure from the compressed striker spring, setting off the percussion cap. The flame from the percussion cap travels along the horizontal flame tube to the chamber, or ignites a fuze in the tube (see *a* above). With the safety screw out, the flame passes down to the detonator and causes the mine to explode.

(2) *Mine proper.*—When a load presses on the cover, the cover is depressed with the chamber as a fulcrum, and one or more of the igniters will fire. It is stated in one report that all five igniters will

be fired, but the construction of the mine does not indicate that this would normally occur.

c. To disarm.—There is no apparent receptacle built into this mine to receive a secondary firing device. The British report that because of the construction of the mine, it is unlikely that any of the push-firing devices could be replaced by a pull-type firing device with trip wires. However, because improvised methods or a supplemental charge can be placed under the mine and connected to a release-type igniter, it is important that the area in the vicinity of mines of this type be carefully examined before neutralization is undertaken. The mine may be neutralized by turning down the safety screw marked "SICHER" (safe) clockwise so that the white radial line coincides with the white dot on the mine. If the safety screw is missing, some substitute should be used to close the lower opening of the chamber above the detonator. In the absence of a suitable device to close the opening in the chamber, the mine should be destroyed by explosives. After closing the opening (7), the mine should be lifted carefully, the nuts (4) on the bottom body cover unscrewed, and the top cover removed. Apparently the detonator assembly and igniter assemblies, all of which are still secured to the top cover, will come free of the body and lower cover of the mine when the top cover is raised. Finally, the detonator may be removed by unscrewing the collar. The five igniters may be removed by unscrewing the nuts (11).

d. To arm.—The mine apparently comes fully assembled with the detonator and the igniters in place. In this case, it is only necessary to remove the safety screw cap (18) and the milled safety screw marked "SICHER" (safe). The safety screw can be removed by turning it counterclockwise. Replace the cover to prevent dirt and debris from entering the chamber.

SECTION VI

HEAVY ANTITANK MINE

Heavy antitank mine.....	Paragraph 46
--------------------------	-----------------

46. Heavy antitank mine (figs. 27 to 35 incl.)—German heavy antitank mines are primarily designed for road blocks, and normally are embedded in concrete in a roadbed. They are so camouflaged that the roadbed appears to be undisturbed. Inasmuch as the laying of heavy antitank mines takes considerable time, they are not likely to be found in territory which has been in enemy hands for a short period of time. Owing to the difficulty of hiding the evi-

dence of disturbance in placing the mine and in matching the color and texture of the existing road surface, their presence can usually be detected from any slow-moving vehicle. However, if the mines have been installed for any length of time, it may be difficult to detect them, particularly if there has been considerable road patching in the vicinity. The charge of an individual mine is sufficient to damage seriously the heaviest tank, and has been known to overturn a 20-ton tank. A dummy mine of similar construction is frequently used and great care must be exercised to determine whether the installation is a dummy or a live mine.

a. Description.—This mine is rectangular in shape, and its case and many of its component parts are made of cast iron. It is 17 inches long by $15\frac{3}{4}$ inches wide by $10\frac{1}{2}$ inches high. The total weight of the mine is approximately 300 pounds. It consists of a box, a cover plate, a removable plug, and one or more firing mechanisms. A detailed description of each part follows:

(1) *Box* (figs. 27, 28, and 29).—The box is made of cast iron and its dimensions are the same as those given in the description of the mine. Within the box (1) is placed the main charge (4) (see fig. 29) consisting of 84 blocks of TNT. The charge weighs 37 pounds and is contained in a zinc or galvanized iron box the lid of which is held in place by either a wire or a webbed strap. Three posts (5), which are drilled and tapped at the top, project vertically from the floor of the box (fig. 29), and support a base plate (6) (fig. 29) which in turn supports the main firing mechanism. The base plate is screwed to the supports by studs (11) (fig. 28). Holes (7) (fig. 29) are provided in the floor of the box for anchoring it in place by either bolts or stirrups. A centrally located hole (8) is also provided, to take the standard (German) pull igniter Z. Z. 35 (see par. 26) for the purpose of connecting an additional explosive charge in the form of a booby trap. Adjacent to the top corners of the box and away from the firing mechanism end, journals (9) are provided (fig. 27) in which trunnions (10) formed in the cover plate (2) have bearing (fig. 31). The journals and the trunnions form hinges for the cover plate. The supporting plate (6) is fastened by studs to the posts. A stud (12) is screwed into the plate and supports a helical spring (13) in a vertical position (fig. 30). The spring is formed from square section spring steel approximately $\frac{1}{8}$ inch square.

(2) *Cover plate and pedal* (figs. 27, 29, 31, and 32).—The cover plate fits into and covers the top of the box. When the cover plate is in position, the trunnions are fitted into the journals and a lug (14) formed under the free (swinging) end of the cover plate rests on

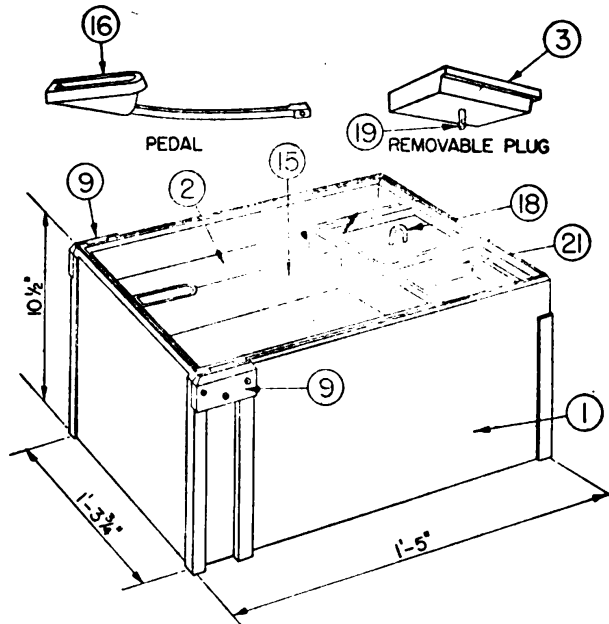

PERSPECTIVE OF BOX AND COVER PLATE

FIGURE 27.—Heavy antitank mine.

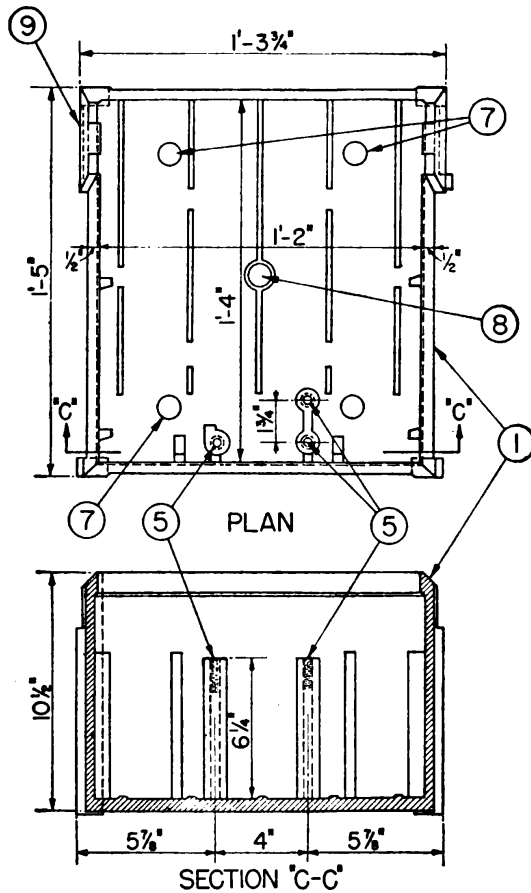

FIGURE 28.—Heavy antitank mine—plan and section of box.

the helical spring which holds the cover plate level with the top edges of the box. One corner of the cover plate has a rectangular recess into which is fitted the removable plug (3). The cover plate is provided with top recesses into which road material may be inserted to match the surrounding road surface. The undersurface of the cover plate is deeply grooved or scored to form a grid (fig. 31) so that the cover will form shrapnel when the mine explodes. The cover plate is also provided with a pedal housing (15) (figs. 27 and 29) into which a pedal (16) (fig. 32) is inserted. The pedal is found with several short strings or wires (17) attached to its end (fig. 29). The exact purpose of the pedal is not clear, but it is

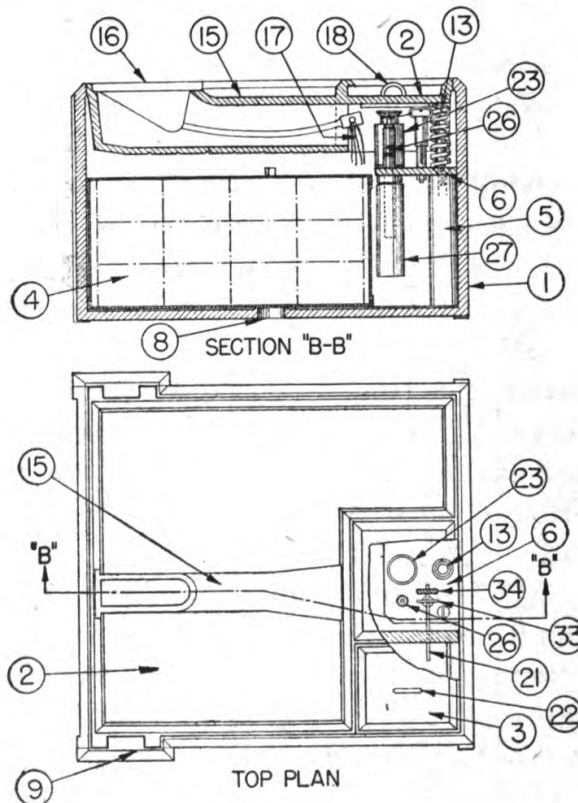

FIGURE 29.—Heavy antitank mine—plan and section.

assumed that it is used to extract the safety pins of the firing mechanism by means of the strings or wires. It is stated in the latest information available that a pressure of 100 pounds on the pedal may fire the mine. However, the exact construction is not clear. The pedal may also be fastened to a booby trap, and therefore great care must be taken in removing it from the cover plate. A U-bolt (18) is provided on the top surface of the cover plate for lifting the plate.

(3) *Removable plug* (figs. 27, 29, and 31).—The removable plug is rectangular in shape and fits into the corner recess of the cover.

To its underside is attached an eyed rod (19) which projects through the hole (20) of the cover plate floor when the plug is in place. On the top side of the plug is attached a U-bolt (22) which is used to lift the plug. The plug provides access to a locking pin (21).

(4) *Firing mechanism* (figs. 29 and 30).—The firing mechanism consists of the following:

(a) *Main push igniter*.—A standard push igniter (23), type D. Z. 35 (see par. 28), is mounted on the base plate by being screwed into the hole provided for it in this plate. A detonator and booster charge (24) is mounted beneath the plate (fig. 30). The booster charge is 4 inches long, and $1\frac{3}{4}$ inches in diameter. When pressure is applied to the cover plate the head (25) of the igniter is depressed downward, and the igniter fires the detonator and booster charge and the main charge.

(b) *Pull igniter*.—A standard pull igniter, type Z. Z. 35 (26) (see par. 26), is used as a booby trap device for the mine. The igniter (26) is mounted on the base plate and is provided with a second detonator and booster charge (27) mounted below the supporting plate (fig. 29 B-B). The projecting head of the pull pin (28) is connected by a wire or cord (29) to an auxiliary firing assembly (32). A dowel pin (30) is mounted on the base plate (fig. 30). A small helical spring (31) rests on the head of the dowel pin and is held in place by a sleeve (32) which rides over the dowel pin. The closed head of the sleeve is provided with a loop (33) to which the wire (29) is fastened. When the cover plate is in place, the lug presses on the eye loop (33), thus compressing the spring. To keep the sleeve from rotating, it is provided with a lug which rides in a groove formed in the dowel pin. The locking pin passes through the loop and is locked to the cover plate by a bracket (34) (fig. 31). If the cover plate is lifted, the sleeve is pulled upward, and at the same time the wire pulls and fires the igniter (26). The igniter fires the detonator and booster, which in turn explodes the main charge. Even if the locking pin is removed, care must be exercised not to lift the cover quickly, as the spring, which is in compression, will force the sleeve upward with sufficient strength to fire the igniter. This firing mechanism constitutes a booby trap.

(c) *Additional booby trap devices*.—Pull igniters (not shown in the drawings) may be installed to provide booby traps while the mine is disarmed. A wire may be attached to the eye of the rod (19), shown in figure 27, of the removable plug and to pull igniter below the cover plate, which will be fired if the removable plug is extracted. It is also stated that pull igniters may also be inserted within the blocks of the charge. It is the practice of the Germans to insert, in each standard block of explosive, a threaded metal sleeve to accommodate

a standard pull igniter. Thus any two blocks may be interconnected by an igniter which will fire upon being separated. This also is of the nature of a booby trap. An additional firing device and charge may be connected to the hole (8), shown in Figure 28, in the base of

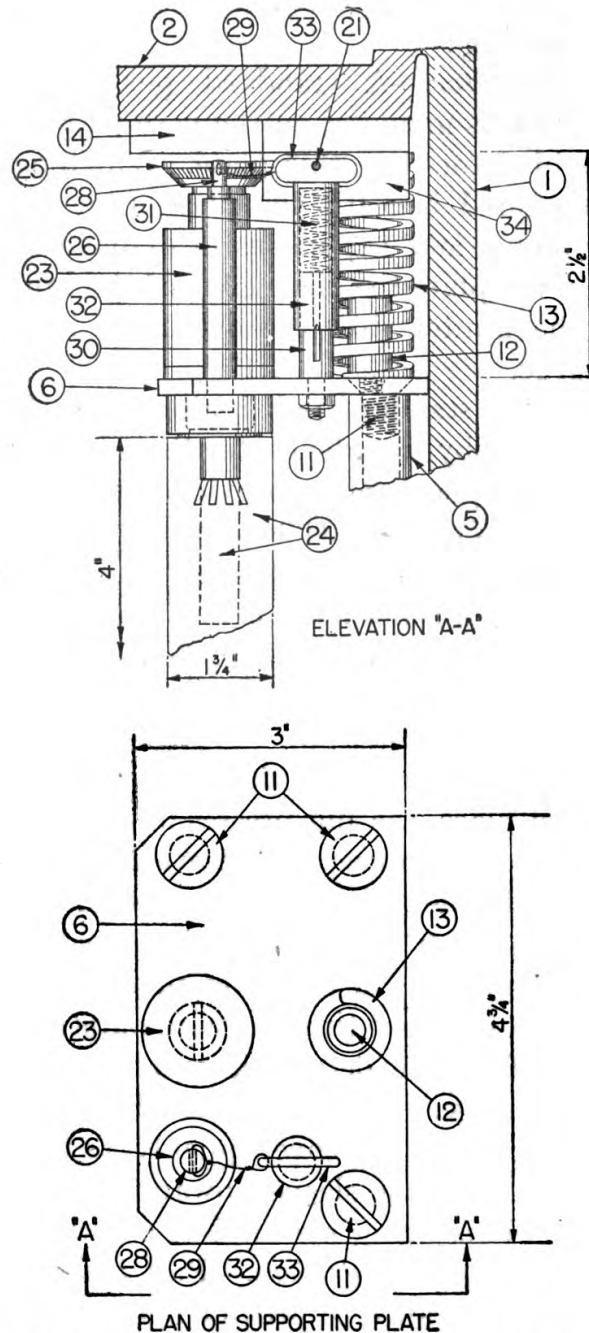

FIGURE 30.—Heavy antitank mine—details of firing mechanisms.

the box, which will fire if the box is lifted. This also is considered a booby trap.

b. Employment.—This mine is used for road blocks where action has been static for a period of time. The length of time required to

lay the mines prevents their effective use in fast moving warfare. The patterns used in laying these mines are described in section XI, chapter 2. Great care must be taken in searching for detours around these mine blocks. Possible detours are often filled with other types of antitank mines and booby traps. Unless a simple passageway through the block can be found by locating the dummy mines, investigation by personnel thoroughly trained in locating and disposing of enemy mines is essential. No attempt should be made to remove branches, loose wire, or general debris until such investigation has been made. The British require these heavy antitank mines to be handled only by trained personnel of the Royal Engineers.

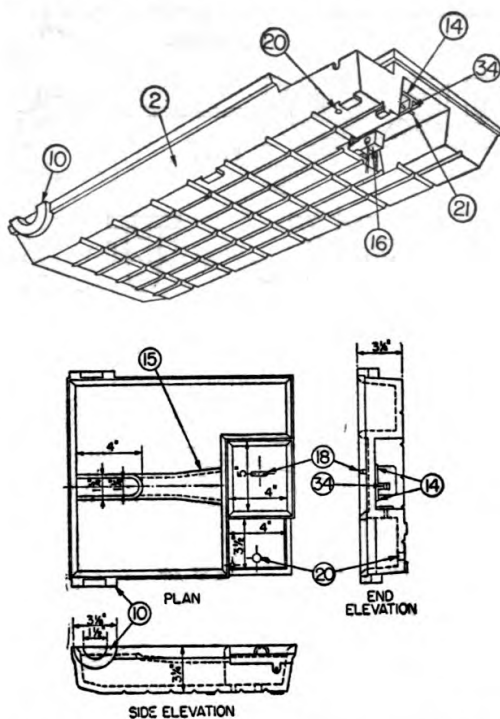

FIGURE 31.—Heavy antitank mine—cover plate.

c. Operation.—The mine is fired by a downward pressure exerted on the cover plate, which pivots on the trunnions. This pressure compresses the main pressure igniter, which fires the charge. The height of the pressure igniter head may be adjusted so that varying degrees of compression of the helical spring, holding up the cover plate, will fire the mine. Thus, the mine may be set to fire under the weight of a man or reconnaissance vehicles, or it may be set so that it will explode only under heavy tanks. Also, when the mine is provided with booby traps it may be actuated in a number of different ways. The main booby trap is the pull igniter. The mine may also be fired by lifting the removable plug when dismantling the charge, when removing the pedal, or when removing the box from its hole in the road.

d. To disarm.—Owing to the construction of this mine and the various combinations of firing devices which may be installed therein, great care must be exercised during every step of the disarming procedure. The weight of some of the parts, and the care required in handling them, necessitates mechanical assistance. A trestle (fig. 33) with a pulley is therefore necessary. The one illustrated has been devised by the British for this work. However, a similar improvised trestle can also be made in the field. The trestle is placed over the

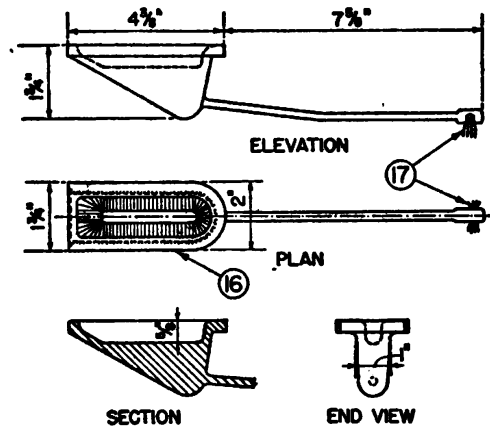

FIGURE 32.—Heavy antitank mine—details of pedal.

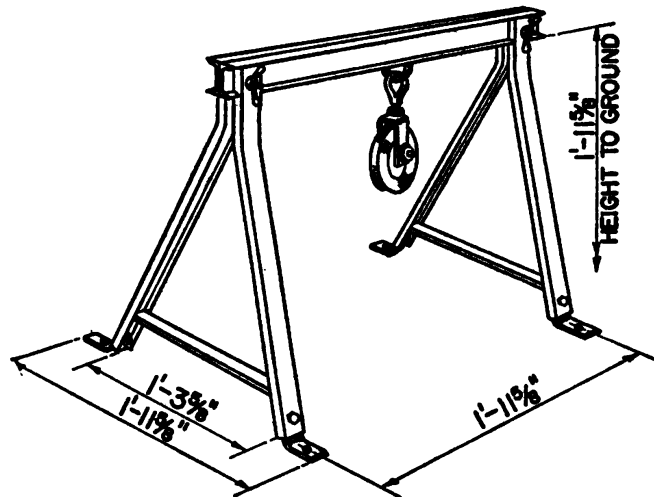

FIGURE 33.—Trestle gantry for lifting mines.

mine, and a rope, passed over the pulley, is attached to the part it is desired to lift. All personnel moves away a distance, and the part is slowly raised. At any time, the rope may be made fast while further close investigations are made. If during the process of disarming there is any feeling of tension in lifting or removing any part, no further movement should be made without careful investigation. Following is a detailed description of the disarming process. Investigate the removable plug, which is generally found on the enemy

side of the mine. Lift the plug very carefully until it is just possible to see into the recess in the cover plate. If the rod (19) has no strings or wires attached, the plug can be lifted clear. Otherwise, the strings or wires must be cut. Pull out the locking pin. Very carefully and slowly, lift the free edge of the cover plate until it is possible to see the inner end of the pedal arm (16) (see fig. 31). If there are cords attached to the pedal arm, examine them carefully and cut them with scissors if no tautness exists. At this point, the pull igniter cord (29) should also be cut. Lower the cover plate and withdraw the pedal. This must be done with great care, as an additional igniter may be attached to it. If there is any feeling of tension, further withdrawal of the pedal must cease, and an examination made to determine the cause of the tension. Raise the cover plate slowly and carefully, and let it rest on its hinges. Neutralize the main pressure igniter and the pull igniter by inserting safety pins or pieces of wire in the holes provided. If there is an igniter which was attached to the rod of the movable plug, neutralize this igniter also. Examine the mine or web belt around the main charge box, and if there is no tension it may be cut. Remove the lid of the main charge box carefully. Any feeling of tension requires careful examination. Remove the charge, *one piece at a time*. This is essential, as several blocks may be joined together with concealed igniters. With the same care, remove the empty box which contained the charge. Unscrew the detonators carefully, with the booster charges (24) and (27), and remove them from the box. Then remove the detonators from the booster charges at a safe distance from other mines. If the detonators are not inserted in the booster charges, then the latter should be removed first before the detonators are unscrewed. Remove the supporting plate with the firing mechanism by unscrewing the studs. Examine the holes (7) and (8) in the bottom of the box to see if there are any strings, etc., attached, in case there is a Teller mine or other booby trap below the mine. Replace the cover plate and the removable plug, so that the road can be used by vehicles.

e. To destroy.—Destroying the mine in place results in considerable damage to the road, and the tactical situation may require that the mine be removed. However, since the mine is difficult and hazardous to disarm, and the time required for disarming is considerable, it may in the end be more expedient to destroy it in place. In that event, proceed as follows: Remove carefully, from the concave top of the cover plate, sufficient of the road filling material to uncover the U-bolt (18) used for lifting the cover plate, and attach a long, stout cord to the U-bolt. Build an improvised A-frame over the mine, and pass the cord over the frame. By this means, vertical lift will be attained. Take the end

of the cord to a safe distance and pull on the cord. This should lift the cover plate, thus firing the mine. If the mine does not fire when the cover plate is raised, examine the mine to see whether it is a live mine. If it is, place a block of explosive on the lid of the main charge box and detonate it. There may be a condition where the road filling material has so solidified that it is impossible to uncover the U-bolt without the risk of exerting undue pressure on the cover plate. In such an

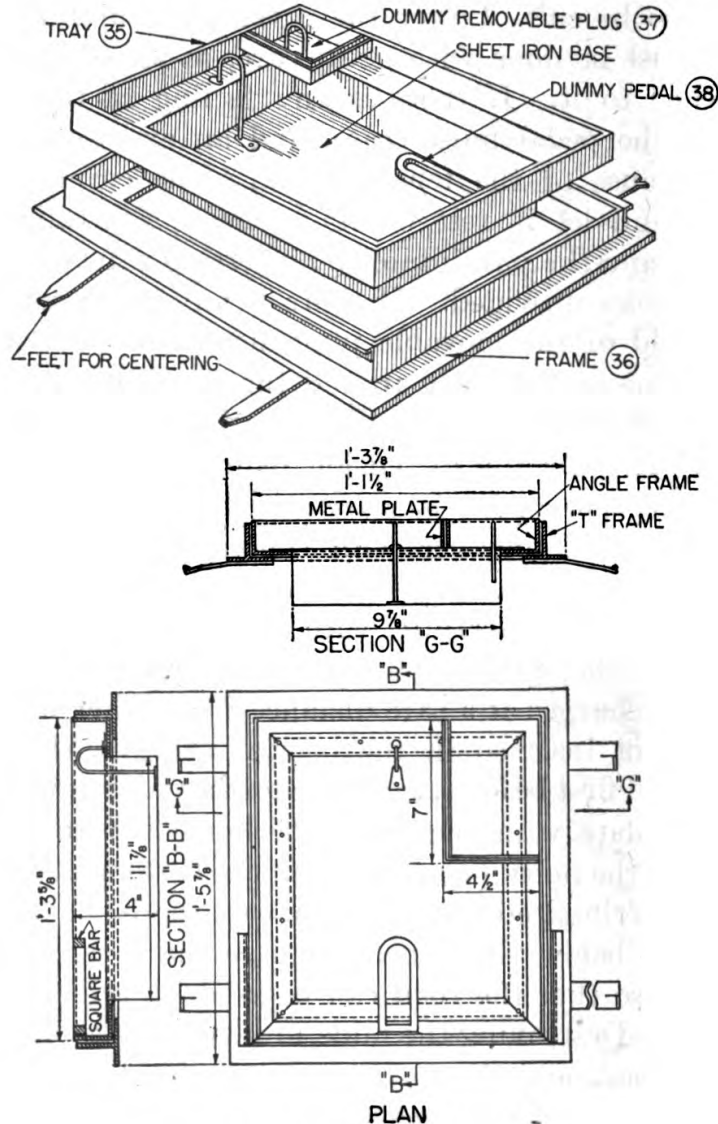

FIGURE 34.—Dummy mine.

event, the best method of destroying the mine will be to detonate a number of blocks of explosive on the surface of the mine where the main firing mechanism is located.

f. To rearm.—If it is desired to rearm the mine, in the event of a counterattack, proceed as follows: dig a hole in the road about 2 feet 6 inches square, by 1 foot 6 inches deep. Level off the bottom so that

the upper edge of the box will lie flush with the road surface. Place the box in the hole and fill around with concrete, or other road material, to match the existing surface. Install and connect the various parts of the firing mechanism, including the detonators and booster charges. Do not remove the safety pins. Place the main charge in the box. Remove the safety pins. Replace the cover plate and gently lower onto the helical spring. Slip the locking pin through the hole in the cover plate, through the loop (33), and into the bracket (34). Place the removable plug in the position. Fill in the cover plate with road material to match the surrounding road surface. The mine is thus armed and, if desired, booby traps may be added.

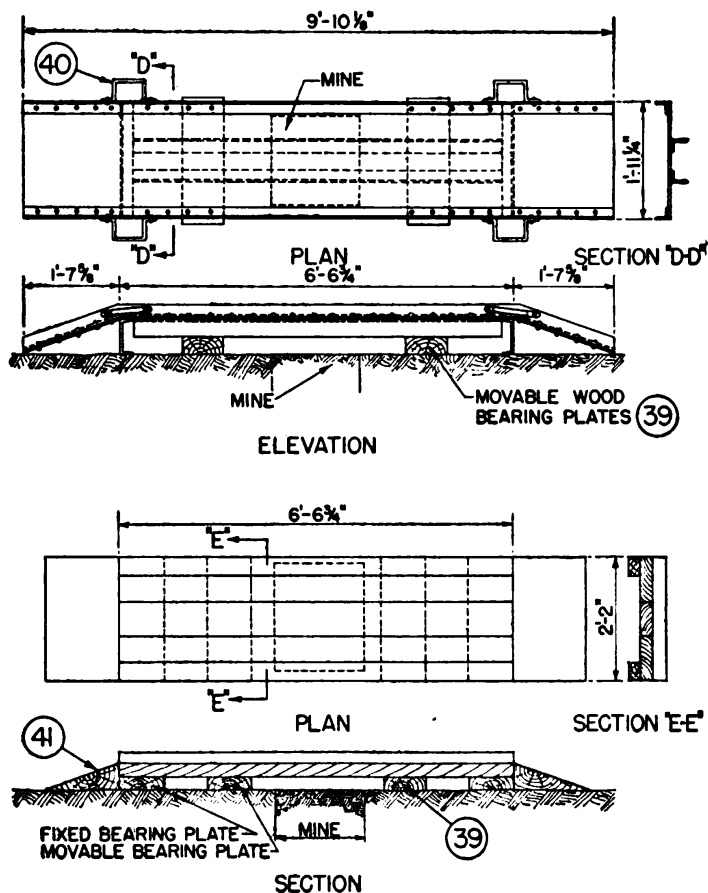

FIGURE 35.—Portable bridges for crossing mine fields for tanks or other vehicles.

g. Dummy mine.—The dummy mine (fig. 34) consists of a tray (35) with a sheet iron base resting in a framework (36) embedded in a concrete block. It has also a dummy removable plug (37) and dummy pedal (38). These mines are located in a road block in known positions to permit the safe passage of German vehicles, or are clumsily concealed in order to induce vehicles of an opposing force to bypass the dummy mines and pass over live mines more cleverly concealed.

h. Portable bridges for crossing mine fields (fig. 35).—The disposal of these mines by disarming is a long and slow process. If the mines are exploded, the road is damaged and traffic seriously impeded. Therefore, the British have developed light bridges, made of either steel or wood, which permit leading units of an attacking force to pass over a mine and thus maintain close contact with the enemy. The dimensions of these bridges are shown in figure 35. Each type has movable wooden bearing plates (39) which are placed on either side of the mine. The bearing plates should be spread as far as practicable, considering the load carried, in order to obviate possible pressure on the mine through the soil. The bridges must be pinned to the roadbed to prevent creeping. The steel bridges are pinned through the handles (40) and the wooden ones are pinned through the wood ramps (41). Two methods of carrying these bridges have been tried: tanks of leading units in an assault carrying a set, and small trailers attached to armored vehicles carrying several sets.

SECTION VII

RAILWAY MINE

	Paragraph
Railway (electrically operated) mine-----	47

47. Railway (electrically operated) mine (fig. 36).—This mine is electrically operated and is designed for the disruption of railway communications.

a. Description.—The railway mine is housed in a wooden box and its total weight is approximately 13 pounds, of which 8½ pounds is the explosive charge of TNT in blocks. In addition to the charge, the mine is provided with a time switch assembly (1), a combined switch (2), a secondary electric detonator (3), and a battery (4). Following is a detailed description of the principal parts:

(1) *Box.*—The box (5) is made of wood and is 9 inches square by 4¼ inches high. The lid (6) of the box is held down by screws and has two openings. One opening (7) forms a socket and provides a sliding contact with the circuit for the secondary electric detonator and the other permits the pressure head (8) of the combined switch to project above the box. The opening around the head is sealed by a rubber diaphragm (9). On one side of the box is a sliding plate (10) covering a hole (11) which forms a socket and provides a sliding contact with the circuit for the time switch assembly. Just around the corner are located two small sockets (12) which are used for testing the delay circuit. An additional hole (13) is located on the same side and may be used for an auxiliary detonator or igniter.

(2) *Time switch assembly.*—The time switch assembly is made up of a clock, a setting disk, a switch, and the main electric detonator (14). The setting disk is located at the head of the clock and is graduated from 1 to 21, indicating a delay time in days. By means of this disk the clock can be set to close the switch at any desired time within 21 days and fire the mine. The time switch assembly is wired to the combined switch, and together they form the main circuit. The current for operating the circuit is supplied by the battery, which is made up of three flashlight battery cells and gives a voltage of approximately $4\frac{1}{2}$ volts.

(3) *Combined switch.*—The combined switch is a combination pressure and release switch. Its principal parts are the pressure head (8), the release plunger (15), the release spring (16), the connecting rod (17), the safety pin hole (18), the contact plate (19), and the contact rod (20). When operated as a compression switch, it forms a circuit with the time switch assembly. When operated as a release switch, it forms a circuit with the secondary electric detonator.

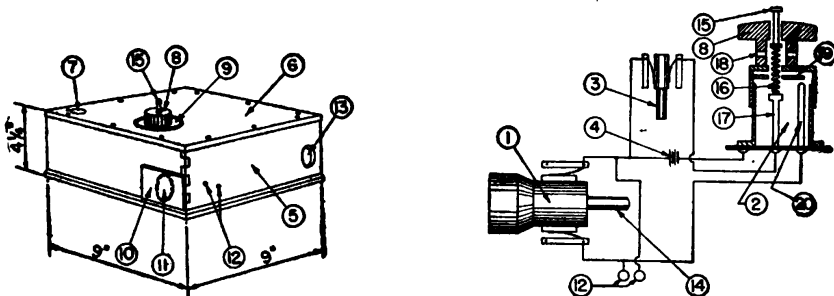

FIGURE 36.—Electrically operated railway mine.

b. Employment.—This mine is designed to be used under a railroad tie or sleeper so that it will explode when a train passes over it, or it may explode after a set period of time has elapsed. The various methods of detonation possible with this mine indicate that it may have a great number of uses. However, available information does not mention any other uses.

c. Operation.—The mine is laid under a railroad tie so that the tops of the compression head (8) and the plunger (15) just touch the underside of the tie. In this position of the combined switch the mine may be fired in one of the following two ways:

(1) The clock mechanism in the time switch assembly is set for a specified delay by adjusting the graduated disk. The pressure head is screwed down, thus closing the switch between the plate (19) and the rod (20). At the expiration of the time delay, the switch in the assembly closes and completes the main firing circuit. The main detonator is fired and the charge is exploded.

(2) The clock mechanism in the assembly is set as described above. At the expiration of the time delay, the switch in the assembly closes. Afterwards, upon the passage of a train along the tracks, the pressure head is depressed and the plate makes contact with the rod, thus completing the main firing circuit which fires the detonator and the charge. The mine may also be exploded by the secondary electric detonator, which is in circuit with the release mechanism of the combined switch. This circuit constitutes a booby trap and operates as follows: If an attempt is made to move the mine from under the tie, the plunger is forced upward by the compressed spring (16), and its bottom flange comes in contact with the pressure head. This contact closes the secondary circuit, thus firing the detonator and exploding the mine.

d. To disarm.—When this mine is discovered in place, care must be taken not to move it. Disarm as follows: Remove any material which may be concealing the mine. Search for pull or release firing devices which may have been inserted in the opening (13). If any is present, neutralize it by placing a nail or safety pin in the safety pinhole and then cut the trip wire. Locate the sliding door (10) covering the time switch assembly. Slide it open and pry out the time switch assembly with the detonator (14). A screw driver may be used for this purpose if necessary. Locate the secondary electric detonator (3) in the top of the mine at (7) and pry it out. If the detonator is not accessible, it may be necessary to hold the release plunger down and turn the mine until the secondary detonator is exposed. The mine is now disarmed and can be moved. During the process of disarming, the following precautions should be observed: Do not move the mine until all detonators have been removed. *Do not insert a metal pin or nail in the safety pin hole* while the secondary detonator is still in the mine. Do not allow the release plunger to rise while the secondary detonator is still in the mine. Do not exert any pressure on the pressure head while carrying out any of the above operations.

e. To arm.—When it is desired to use the mine against the enemy, it may be armed as follows: After making sure that the time switch assembly and the electric detonator have been removed from the mine, depress the release plunger and hold it in place by inserting a pin in the safety pin hole. Place the mine under a railroad tie or sleeper in such a way that the pressure head bears on the underside of the tie but is not depressed by it. Remove the safety pin from the safety pin hole. Set the clock to close the switch in the time switch assembly at the desired time and insert the assembly with the detonator (14) in the hole (11). Finally, insert the electric detonator

(3) in the plug (7) and cover and camouflage the mine. A secondary pull igniter may also be inserted in hole (13) to act as a booby trap, and its safety pin should not be removed until the trip wires are laid.

f. Test.—The test for battery voltage may be made by inserting leads of a voltmeter in the test sockets (12) and pressing down on the pressure head of the combined switch. When this test is made, the time switch assembly and the secondary electric detonator must be removed from the mine.

g. Caution.—A metallic pin must not be inserted into the safety pin hole unless the secondary electric detonator has been removed.

SECTION VIII

ANTIPERSONNEL MINE

	Paragraph
Antipersonnel bounding mine (silent soldier)-----	48

48. Antipersonnel bounding mine (silent soldier) (figs. 37 and 38).—This mine is the standard German antipersonnel mine. It is designed for firing by either a standard push- or pull-type igniter or an electrical detonator. For transporting, the mines are packed three in a wooden box which, when filled, weighs about 33 pounds.

a. Description.—The mine is cylindrical in shape and is 5 inches high and 4 inches in diameter. It weighs approximately 9 pounds of which 1 pound is the tolite (TNT) charge. It has an outer cylindrical metal canister (1), into which an assembly is inserted consisting of an outer steel cylinder (2) and an inner steel cylinder (3) closed at both ends by a base plate (4) and a cover plate (5). The annular space between the cylinders (2) and (3) is slightly less than $\frac{1}{2}$ inch wide and is filled with about three hundred and fifty steel balls (6). The steel cylinders (2) and (3) are approximately $\frac{1}{16}$ inch thick. A tube (7) passes through the center of the cover plate into the base plate along the axis of the mine. Three brass detonator tubes (8) spaced radially around the tube (7), 120° apart, are located in the mine with access through the cover (5). The detonator tubes are closed by screw plugs (9) and washers (10) in the cover and are screwed on short-time delay brass tubes (11) in the base plate. When the mine is unarmed, the tube (7) is held locked in position by the screw collars (13) and (14) and is closed at its upper end by the screw cap (12). A $4\frac{1}{2}$ -second delay powder tube (18) is screwed to the collar (14). The base plate has a recess which contains about 1 ounce of powder charge (19), which is covered and held in place by a soft metal plate (15) which

is fastened to the base plate by a large annular washer and bolts. The tube and the screw collar (14) seem to be locked into the opening provided in the base plate, by a setscrew (16). An opening, closed by a screw plug and washer (20), is provided in the cover for inserting the tolite (TNT) charge (17) which fills the free space in the cylinder (3). The entire assembly is closed by a flange ring (21) which is soldered or brazed to the top edge of the canister.

b. Employment.—This mine is most frequently used in antitank minefields (see sec. XI, ch. 2). It is particularly adaptable for use in woods, where the mine is easily camouflaged. When used as a pressure-operated mine it is laid in a conical hole approximately

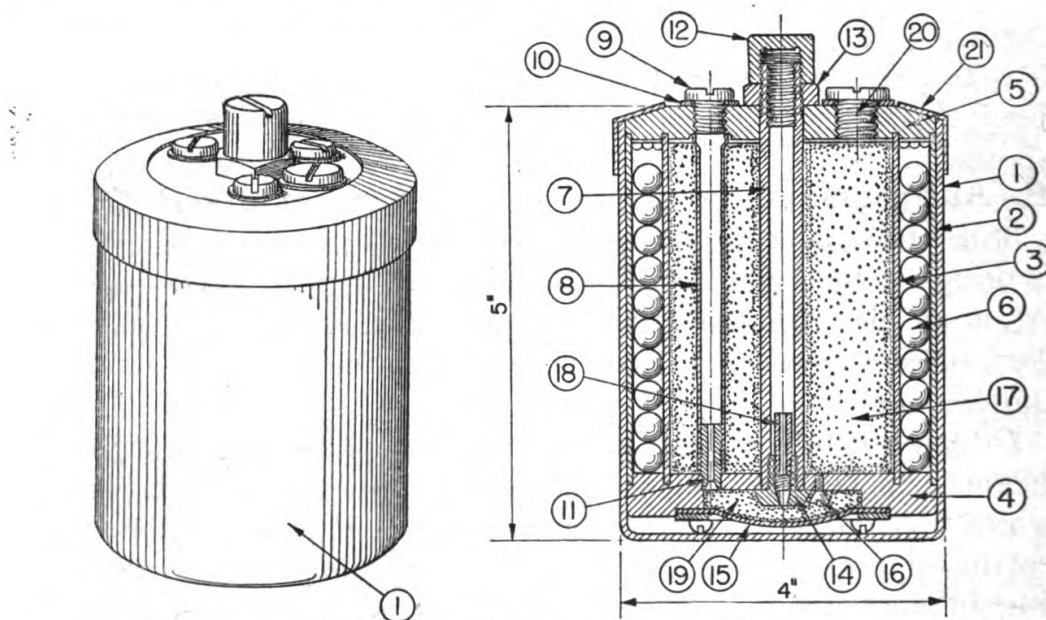

FIGURE 37.—Section and perspective view of antipersonnel bounding mine (silent soldier).

8 $\frac{3}{4}$ inches in depth (see fig. 38). The antennae (24) of the igniter project above the general surface of the ground and are camouflaged by a thin layer of earth, leaves, or grass. When used as a pull-operated mine it is laid in a cylindrical hole approximately 8 $\frac{3}{4}$ inches deep and is held in place by four stakes (25). Trip wires (26) are attached to the igniters (23) and are stretched out in opposite directions. The wires are run 4 inches above the ground and pass through eye screws fixed to the top of wooden stakes (27). The recommended length for the trip wires is 21 yards with the supporting stakes (27) at 7-yard intervals.

c. Operation.—The mine may be operated by pressure or by pull. If it is to be operated by pressure, a standard pressure igniter (24), type S. Mi. Z. 35 (see par. 29), is screwed into the top of the tube (7) (see fig. 38). If the mine is to be operated by a pull, a Y-connection (22) is screwed into the top of tube and two standard igniters of the

type Z. Z. 35 (see par. 26) or Z. U. Z. Z. 35 (see par. 27) are screwed into the branches of the Y. In either case, when an igniter is fired, the flame produced ignites the $4\frac{1}{2}$ -second delay powder of the tube (18), which in turn ignites the powder charge (19). The powder charge then explodes, blowing out the soft metal plate and forcing the mine proper out of the canister and into the air. At the same time the explosion of the powder charge ignites the delay powder tubes. The delay in these tubes is long enough to permit the mine to rise 3 to 5 feet into the air before the detonators in the tubes (8)

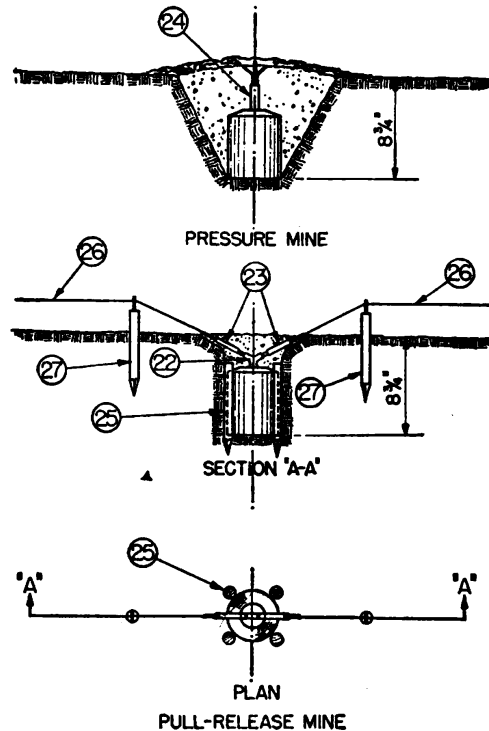

FIGURE 38.—Method of placing the antipersonnel bounding mine (silent soldier).

are ignited. The detonators then explode the charge (17), and the steel balls are dispersed in all directions. The effective range of these balls is between 150 to 200 yards.

d. To disarm.—Before disarming the mine it is necessary to neutralize the igniters by inserting a safety pin or nail in the safety pin hole as described for the particular igniter. If the igniter is the pull type, cut the trip wires attached to it. Unscrew the igniter from the tube (7) and remove from the mine. Unscrew the plugs (9) and remove the detonators from the three detonator tubes. Remove the detonators by turning the mine over gently and tapping the bottom. Replace the plugs in the cover and, if available, replace the cap. These antipersonnel bounding mines must never be stacked unless they have been disarmed.

e. To arm.—Unscrew the plugs and insert three standard non-electric detonators, open end downwards, in the detonator tubes. Replace and screw in the plugs. Remove the screw cap and screw the selected igniter on the tube (7), making sure that the safety pins are in place. Finally, after the mine is laid, remove the safety pins.

SECTION IX

IMPROVISED MINES

	Paragraph
General	49
Improvised high-explosive shell antitank mine.....	50
Druckbohlenmine (pressure plank mine).....	51
Kammeiermine (Kammeier's mine).....	52
Rampenmine (ramp mine).....	53
Burhenn-Minen (Burhenn's mines).....	54
Schlusselfmine (key mine).....	55
Hangemine (hanging mine).....	56
Schleudermine (sliding mine).....	57
Elektrischminen (electric mines).....	58
Stick grenade mine.....	59
Stick grenade cluster mine.....	60
Stolpendrahtmine (stick or block wire mine).....	61
Fussschlingenmine (foot snare mine).....	62
Tretmine (tread mine).....	63
Brettstuckminen (board mines).....	64
Druckbrettmine (pressure board mine).....	65

49. General.—The German instructions pertaining to improvised mines contemplate that such mines be used for antitank, antivehicle, and antipersonnel purposes. In the preparation of improvised mines the Germans generally utilize standard igniters in conjunction with standard detonators, standard charges, standard mines, grenades, or high-explosive shells, and firing is accomplished by pressure, pull-release, or tension-release firing devices. Electrical firing is sometimes resorted to, as is delay action firing.

50. Improvised high-explosive shell antitank mine.—*a. Description.*—This mine is a high-explosive shell with its fuze replaced with a standard pressure-type igniter. Standard igniters are described in section II.

b. Employment.—The mine is buried in a road or trail. A plank may be placed over the pressure head of the igniter.

c. Operation.—The passage of a vehicle over the mine will fire the igniter and explode the mine.

d. To disarm.—Neutralize the igniter as described in section II.

51. Druckbohlenmine (pressure plank mine) (fig. 39).—*a. Description.*—The Druckbohlenmine (pressure plank mine) is an im-

provided antitank mine consisting of two or more explosive charges (1) equipped with push-type igniters (2) of the Z. D. Z. 29 type for pressure firing. The charges are placed in frames (6) between two planks (3), which are held in place by wires (4) and by spacer blocks (5), the latter being removed when the mine is laid. The bottom plank forms the base of the mine and the top plank, which rests on the pressure igniters, forms the cover. The minimum length of the boards should be equal to the distance between the wheels or tracks of the vehicle against which the mine is to operate and the maximum length should be 15 feet.

b. Employment.—The mine is particularly adaptable for use as a road block. The mine is buried in a trench across the road sufficiently deep to permit the top plank of the mine to be covered with road surface material similar to the remaining road surface.

c. Operation.—When a vehicle passes over the mine, the top plank is depressed, thus actuating the pressure igniters which set off the

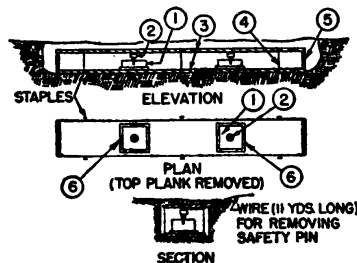

FIGURE 39.—Druckbohle mine (pressure plank mine).

detonators and in turn the main explosive charge. The heads of the igniters are generally set to operate under a pressure of 275 pounds.

d. To disarm.—**Caution:** Do not lift or remove the top plank until the igniters have been neutralized. Remove the road surface material or other means of concealing the mine. Investigate the mine for secondary firing devices and, if any are discovered, neutralize them. Place blocking between planks and then neutralize the igniters. It may be found desirable to remove the mine from the trench after placing the blocking between planks before attempting to neutralize the igniters. Next remove the igniters and the detonators from the charges.

e. To arm.—Set the igniters for the desired firing pressure and assemble the mine. Place the mine in a trench as described in *b* above. Remove the spacer blocks. Attach long wires to the key-like safety pins of the igniters to facilitate the removal of the pins from a distance. Cover and camouflage the mine. Remove the igniter safety pins by pulling on the wires from a safe distance.

52. Kammeiermine (Kammeier's mine) (fig. 40).—*a. Description.*—The improved Kammeiermine (Kammeier's mine) is prepared in the rear area and is transported to the place of use. The mine has two mines (1), which are mounted on two base pieces (1a) approximately 5 feet long. Each mine is generally fitted with three or more Z. D. Z. 29 (push- or pull-type) igniters; two of these igniters (2) are usually prepared for direct pressure firing. The third igniter (3) may be fired by direct pull on trip wires (4) attached between pairs of igniters (3).

b. Employment.—These mines are generally used to prepare rapid road blocks. It is probable that mines are laid in shallow excavations; however, they may be placed on the road surface, probably at points around a bend in the road where they cannot be seen from a distance.

c. Operation.—The mine is fired either by direct pressure on the igniters (2) and (3) or by the wheels or treads of a vehicle pulling on the trip wires.

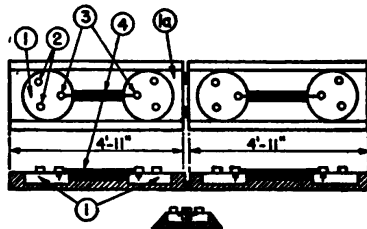

FIGURE 40.—Kammeiermine (Kammeier's mine).

d. To disarm.—Neutralize the igniters and then disassemble the mine.

e. To arm.—Fix the detonators and igniters (2) and (3) to the mine. Fasten the trip wires to the igniters (3). Remove the safety pins. German instructions for the use of this type of mine state that push igniters must be armed before the pull igniters.

53. Rampenmine (ramp mine) (fig. 41).—*a. Description.*—The Rampenmine (ramp mine) is an improvised mine intended for use where the road surfacing does not permit the rapid burying and camouflaging of mines. A ramping crushing plank (1) is mounted on a bevelled edge of a sill plank (2) by hinges or straps (3). Two wedge-shaped wooden blocks (4) mounted on the sill plank support the charges (5), which are provided with the pressure igniters (6) (push and pull standard igniter Z. D. Z. 29; see par. 30). The pressure heads of the igniters are held in contact with the crushing plank by wires (7) fastened to the open edges of the planks (1) and (2). The pressure heads of the igniters are generally set to fire at a pressure of 275 pounds.

b. Employment.—The mine is laid along the edge of the road, hinged edge toward the road. The hinged corner of the mine toward the enemy is wired to a stake (8). The mine is camouflaged. A pull wire or cable is fastened to the other hinged corner, carried across the road, around a tree trunk (or stake), then parallel to the road in the direction of the enemy and around a second tree trunk or stake. The wire is then strung back across the road and anchored to another tree trunk or stake.

c. Operation.—An approaching enemy vehicle strikes the pull wire which swings the mine across the road, hinged edge toward the approaching vehicle. The wheels or track of the vehicle force the crushing plank down on the igniters, thus firing the charges.

d. To disarm.—Neutralize the igniters as described for the combined igniter Z. D. Z. 29 (see par. 30). Remove the igniters and detonators from the mine.

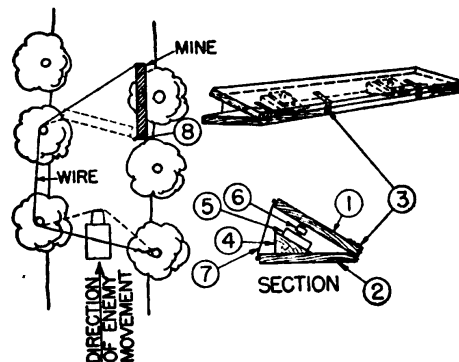

FIGURE 41.—Rampenmine (ramp mine).

e. To arm.—Fix the detonators and igniters to the charge. Then remove the safety pins from the igniters.

54. Burhenn-Minen (Burhenn's mines) (fig. 42).—*a. Description.*—Burhenn-Minen (Burhenn's mines) are antivehicle charges laid as a road block. Each installation consists of a number of explosive charges (1) which are laid in a more or less definite pattern and are connected by an instantaneous fuze or by a detonating cord (2) to a firing assembly at the side of the road. If instantaneous fuze is used, each charge must be fitted with a detonator. The charges are buried at a depth varying from 2 feet 8 inches to 3 feet 4 inches. There is no information available on the details of the charge. The instantaneous fuze has a main lead from the firing assembly, and it is connected to each charge by a branch detonating cord. The firing assembly is generally mounted in a horizontal groove cut in the trunk of a tree. It consists of a pull igniter (3) (type B. Z. 24, described in par. 25) which is fastened to the tree by the staples (4), a detonator (5), and a pull wire (6). The pull

wire is fastened to the igniter and is carried across the road, where it is fastened to a convenient stake or another tree trunk. The pull wire is placed above the surface of the road at a sufficient height to be operated by an approaching vehicle.

b. Employment.—The road block is designed to destroy or incapacitate at one time as many vehicles as possible. Therefore, as conditions dictate, the pull wire may be located (as shown) at the beginning of the block, at the middle, or beyond the block.

c. Operation.—When an approaching vehicle strikes the pull wire, the igniter is fired and the instantaneous fuze is ignited, thus firing all the charges simultaneously.

d. To disarm.—First neutralize the mine by placing a safety pin or wire in the safety pin hole in the igniter. Cut the pull wire. Disconnect and remove the firing assembly.

e. To arm.—Connect the instantaneous fuze detonating cord to the detonator and the igniter. Then connect the igniter to the pull wire stretched across the road.

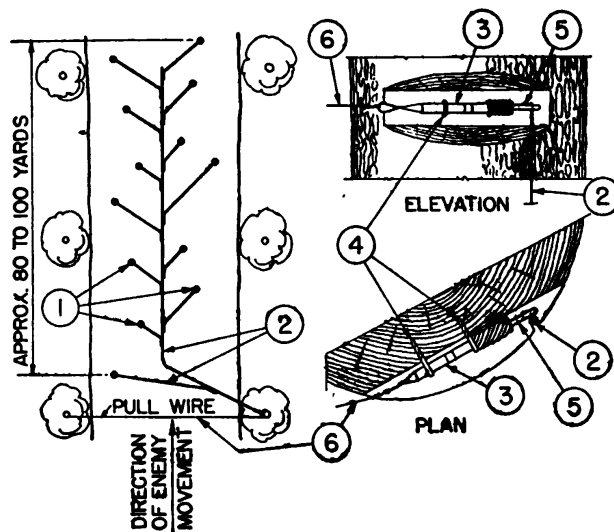

FIGURE 42.—Burhenn-Minen (Burhenn's mines).

55. Schlusselfmine (key mine) (fig. 43).—*a. Description.*—The Schlusselfmine (key mine) is an antivehicle charge laid as a road block. Each installation consists of two or more rather large charges (1) which are buried in the road surface and are connected by a detonating cord (2) to a firing assembly at the side of the road. The detonating cord has a main lead from the firing assembly and it is connected to each charge by a branch detonating cord. The firing assembly is mounted on a "key" or similar support (3), which is in turn supported on two stakes (4) adjacent to the base of a tree trunk, and consists of a push and pull igniter (5). (combined igniter Z. D. Z. 29, described in par. 80), a detonator (6), and a pull wire (7). The pull wire is

stretched across the road and is fastened to a tree or other convenient object on the opposite side of the firing assembly. By means of staples (8) in the tree trunk, the pull wire is brought down and connected to the pull release (9) of the igniter. The igniter is provided with a flexible safety key (10).

b. Employment.—This mine is used as a road block. The charges are so placed in the roadway that they will explode under the passing vehicle.

c. Operation.—When the pull wire is struck by a vehicle, the igniter and detonator are fired, and by means of the detonating cord (2) the charges are exploded.

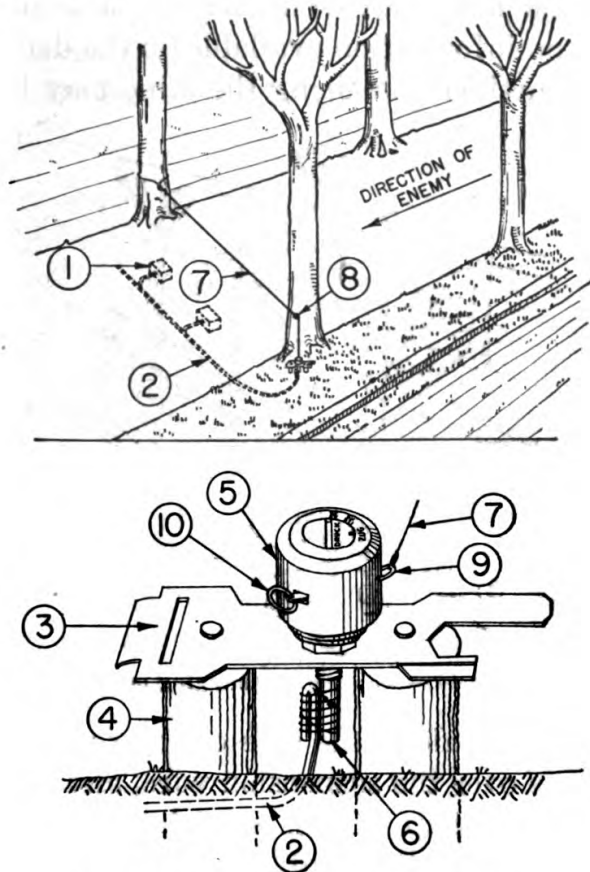

FIGURE 43.—Schlusselform (key mine).

d. To disarm.—Locate the igniter and neutralize as instructed in paragraph 30 for the Z. D. Z. 29 igniter. Cut the pull wire. Finally, cut the detonating cord and remove the detonator.

e. To arm.—Bury the charge and camouflage it in the road after connecting it to the detonating cord. Connect the detonating cord to the detonator. Connect the detonator to the igniter. Anchor the pull wire across the road and connect to the pull release. Finally, arm the igniter as a pull igniter and remove the safety key. **Caution:**

Be sure that tension is not applied to the pull wire when the mine is being set.

56. Hangemine (hanging mine) (fig. 44).—*a. Description.*—The Hangemine (hanging mine) is an improvised delay-action mine of the nature of a vehicular booby trap. The mine (1) is suspended from a wire (2) above the normal vehicular height. A coiled wire (3) connects the suspension wire (2) to a pull igniter (4), which may be type Z. D. Z. 29 or type Z. Z. 35. The mine is a prepared charge or plate mine and is camouflaged by placing a notice (not shown) on the enemy side of the mine. This notice may be, for example, "Tankstekke" (tank stakes), "Rollbahn" (track), "Bahnübergang" (railway crossing), etc.; or the mine may be hidden in the branches and leaves of trees. There is no information available on the details of the mine. Either one of two methods for firing the mine may be used. In the

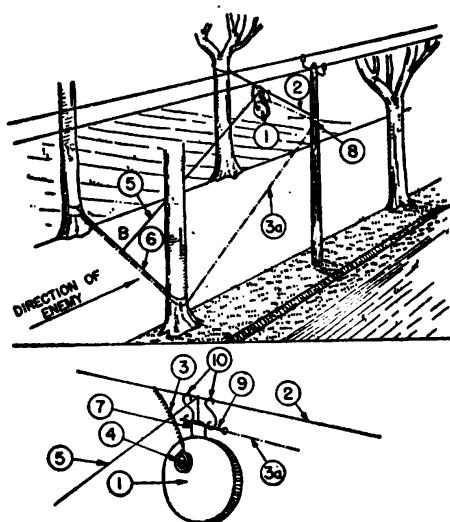

FIGURE 44.—Hangemine (hanging mine).

first method, a wire (5) along the axis of the road is connected to a trip wire (6), passes over the suspension wire, and connects to a loop (7) on the mine. The trip wire is stretched between two trees or stakes above the surface of the road. In the other method, indicated by a dot-dash line, a trip wire (3a) extends across the road and diagonally upwards by the side of the road through a staple (8) to the nail (9). The nail passes through the two "S" hangers (10) and the loop to support the mine.

b. Employment.—The Hangemine is used as a road block.

c. Operation.—The operation of the mine by each of the two methods follows: In the first method the enemy vehicle rides against the trip wire, releases the wire (5), and causes the mine to drop on the approaching vehicle. As soon as the coiled slack wire is fully extended, it operates the pull igniter, and the mine is exploded. In

the other method, the enemy vehicle rides against the trip wire, which pulls the nail out of the loop. The mine drops and explodes as described above. The coiled wire is of sufficient length that when it is extended the mine will explode against the top of the vehicle.

d. To disarm.—If a wire (5) is used, cut the slack wire and lower the mine to the ground. If a trip wire is used, cut the trip wire and the slack wire and lower the mine to the ground. Neutralize the igniter by placing a pin in the safety pin hole. Remove the igniter and its detonator from the mine.

e. To arm.—Connect the igniter and detonator to the mine. Fasten a long string or wire to the safety pin of the igniter. Suspend the mine by either method and complete the installation as described. Finally, pull the safety pin from the igniter.

57. Schleudermine (sliding mine) (fig. 45).—*a. Description.*—The Schleudermine (sliding mine) is an improvised delay-action

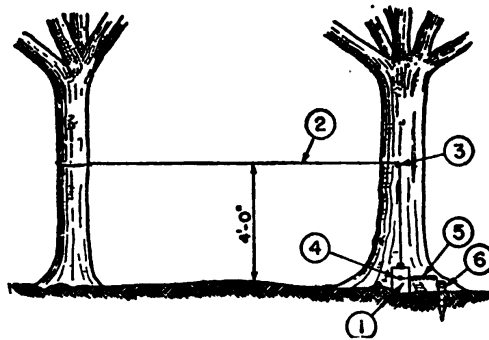

FIGURE 45.—Schleudermine (sliding mine).

mine and is similar to an antivehicular booby trap. The charge of mine (1) is placed at the side of the road at the foot of a tree or post and is suitably camouflaged. A trip wire (2) from the mine passes over a headless nail (3) and is stretched across the road, generally at a height of about 4 feet. The mine is provided with a pull igniter (4), either type Z. Z. 35 or type Z. D. Z. 29 (see pars. 26 and 30). One end of a length of slack wire (5) is connected to the pull pin of the igniter and the other end is fastened to a stake (6).

b. Employment.—The Schleudermine is used as a road block on roads used exclusively by enemy vehicles.

c. Operation.—When a vehicle runs into the trip wire, the trip wire will slide off the headless nail and drag the mine against the side of the vehicle. At the same time the slack wire will become fully extended, thus firing the pull igniter and exploding the mine.

d. To disarm.—Locate the mine and neutralize the igniter by placing a safety pin in the safety pin hole of the igniter. Cut the trip wire and the slack wire. Then remove the igniter and the detonator from the mine.

e. To arm.—Insert the detonator and screw the igniter in place in the mine. Connect the trip wire and the slack wire as described above. Camouflage the mine and remove the safety pin from the igniter.

58. Elektrischminen (electric mines) (figs 46, 47, and 48).—Elektrischminen (electric mines) are fired by closing an electric circuit, either through the action of an enemy vehicle or by a hidden observer. When the mines are actuated by a hidden observer, they are known as Beobachtungsminen (observation mines). There are three types which are fired through the action of enemy vehicles. In all three types the mines (1) are provided with electric detonators and are buried in a roadway so that each mine is located approximately under the wheel or track of an enemy vehicle when the mines are exploded. The minimum weight of the charge in these mines is about 6½ pounds. They are described in more detail as follows:

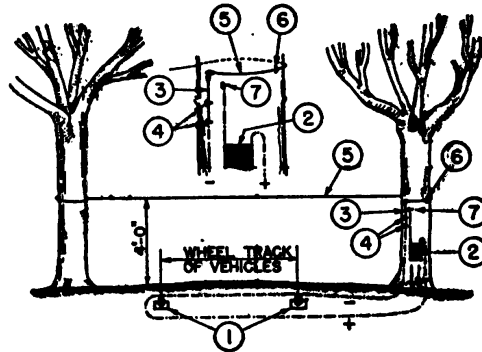

FIGURE 46.—Elektrischmine (electrically operated mine, type A).

a. Type A (fig. 46).—(1) *Description.*—In figure 46, a battery (2) is mounted to a tree trunk. The positive lead of the battery is connected in series to the electric detonators inserted in the mines (1). The negative lead (3) from the mines is brought up the tree trunk, and the end is supported in a vertical position by the two nails (4). The free end of this negative lead is loosely fastened to a pull wire (5), which passes through a staple (6) and is stretched across the road, generally at a height of about 4 feet. A negative lead from the battery is brought up vertically to a nail (7). The tension of the wire (5) must not bend the end of the negative lead. With the exception of that portion of the negative wire above the nails, all the conducting wires are insulated.

(2) *Employment.*—See *d* below.

(3) *Operation.*—When an approaching vehicle strikes the pull wire, the uninsulated end of the negative lead is pulled into contact with the nail, thus closing the circuit and firing the mines.

(4) *To disarm.*—See *e* below.

(5) *To arm.*—See *f* below.

b. Type B (fig. 47).—(1) *Description.*—A battery (2) is mounted on a tree trunk. The positive lead from the electric detonators, mounted in the mines (1), is connected to the battery. The negative lead from the battery is connected to a wire (3) which is stretched across the road and fastened to a tree on the opposite side. The negative lead from the mines is brought up the trunk of this tree and is connected to a second wire (4), which is similarly stretched across the road adjacent to and parallel to wire (3). Wires (3) and (4) are spaced so they do not touch.

(2) *Employment.*—See *d* below.

(3) *Operation.*—When an approaching vehicle strikes the wires (3) and (4) the circuit is closed by direct contact of the bare wires (3) and (4) with the metal parts of the vehicle, thus exploding the mines.

(4) *To disarm.*—See *e* below.

(5) *To arm.*—See *f* below.

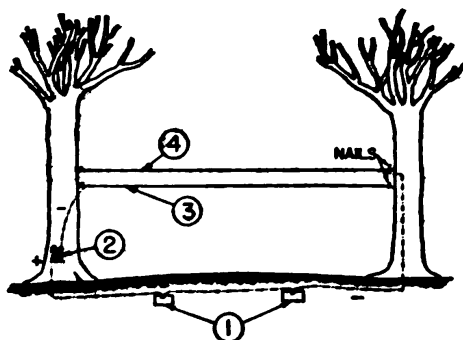

FIGURE 47.—Elektrischemine (electrically operated mine, type B).

c. Type C (fig. 48).—(1) *Description.*—This installation is the same as that of figure 47 except that the wires (3) and (4) are separated horizontally by the thickness of the trees.

(2) *Employment.*—See *d* below.

(3) *Operation.*—When an approaching vehicle strikes the wires (3) and (4), they are forced together. The contact completes the circuit and explodes the mine.

(4) *To disarm.*—See *e* below.

(5) *To arm.*—See *f* below.

d. Employment (types A, B, and C).—All these installations of electrically fired mines are of the nature of antivehicular booby traps and are used on roads exclusively used by the enemy.

e. To disarm (types A, B, and C).—These installations may be disarmed by locating the battery (2) and disconnecting the electrical leads. Then cut the trip wires stretched across the road. Locate the mines (1) and remove the electric detonators.

f. To arm (types A, B, and C).—Place the electric detonators in the mines and bury them. Connect the electric detonators in series

and lay the leads under the road surface to the side of the road. Place the trip wires and connect the wiring to the battery, using care to keep the circuit open.

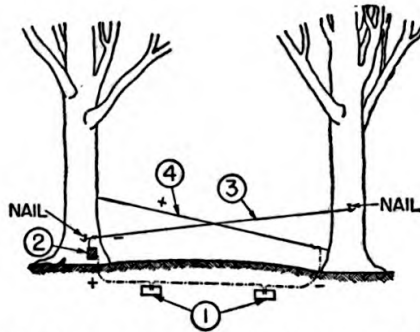

FIGURE 48.—Elektrischemine (electrically operated mine, type C).

59. Stick grenade mine (fig. 49 (A)).—*a. Description.*—The stick grenade mine is an improvised antipersonnel mine consisting of a stick grenade (1) fitted with pressure igniter D. Z. 35 as described in paragraph 28. The igniter (2) is screwed into the head of the grenade, which has a detonator.

b. Employment.—This mine is generally concealed under a board so that it will explode when pressure is applied to the board.

c. Operation.—Pressure on the igniter head causes it to fire the detonator and in turn explode the grenade.

d. To disarm the mine.—Insert a nail or split pin in the safety pin hole of the igniter. Remove the igniter and the detonator from the grenade.

e. To arm the mine.—With the detonator in place in the grenade, screw the igniter to the head of the grenade. Then place the mine in position and remove the safety pin from the igniter.

60. Stick grenade cluster mine (fig. 49 (B)).—This mine is a variation of the stick grenade mine (antipersonnel) described in para-

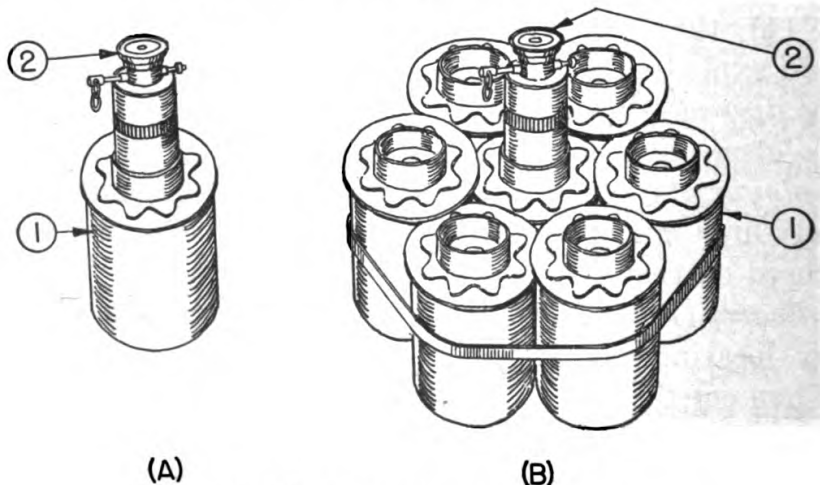

FIGURE 49.—Stick grenade antipersonnel mines.

graph 59. It consists of several stick grenades (1) bound together in a cluster and fitted with pressure igniter D. Z. 35. The igniter (2) is screwed into the head of the center grenade, which has a detonator. The employment, operation, disarming, and arming of this mine are identical to that of the stick grenade mine (par. 59).

61. Stolpendrahtmine (stick or block wire mine) (fig. 50).—*a. Description.*—The Stolpendrahtmine (stick or block wire mine) is an improvised antipersonnel mine of the nature of a booby trap. A stick grenade (1), armed with a wire pull friction igniter of type B. Z. 24 (2) (see par. 25), is buried at an angle and secured by crossed sticks (3). The mine points toward the enemy. A trip cord or wire (4) is fastened to the igniter and is laid under the surface in line with the axis of the mine to a buried stake (5) where it is threaded through a staple. The free end of the cord is provided with a slip noose that is laid on the surface of the ground and probably camouflaged. The cord, as laid, is like a rabbit noose.

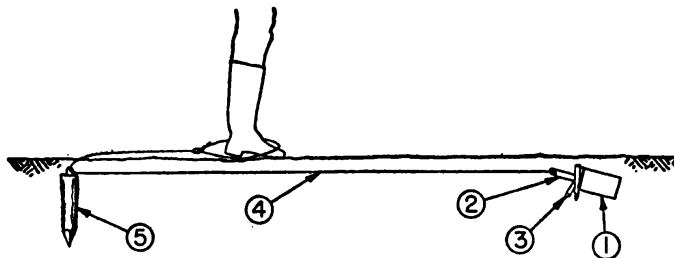

FIGURE 50.—Stolpendrahtmine (stick or block wire mine).

b. Employment.—No stated employment is described. It is assumed that the mine is laid in rough country, in woods, or on trails.

c. Operation.—When a man's foot catches in the noose, the friction igniter is fired and the grenade explodes.

d. To disarm.—Locate the mine and neutralize the igniter according to instructions given in paragraph 25*d*. Remove the mine and unscrew the igniter from the grenade.

e. To arm.—Screw the igniter in the grenade and lay the mine as described and illustrated. Remove the safety pin from the igniter.

62. Fuszschlingenmine (foot snare mine).—The Fuszschlingenmine (foot snare mine) is similar to the Stolpendrahtmine described in paragraph 61. It is a small prepared charge fitted with a pull igniter Z. Z. 35 (see par. 26) and is attached to a stake buried in the ground. Several wire loops or nooses are attached to the igniter and are laid on the ground surface above the mine. When a man's foot catches in one of the loops, the mine is fired. The mine is disarmed by neutralizing the igniter according to instructions given in paragraph 26*d*. Other installations similar to both the

Stolpendrahtmine (see par. 61) and the Fuszschlingenmine may be encountered.

63. Tretmine (tread mine) (fig. 51).—a. Description.—The Tretmine (tread mine) is an improvised antipersonnel mine. It is similar in construction to the Druckbohlenmine described in paragraph 51. A small prepared charge (1) with an igniter (2) of the type Z. D. Z. 29 (see par. 30) is placed between a sill board (3) and a pressure board (4). The boards are about 1 foot square and are held together by wires attached to staples. The igniter is generally set for a pressure of 100 pounds.

b. Employment.—The mine is buried in a square hole below the surface of the ground. After the mine is laid, the sod is carefully replaced over the mine. The mines are located in zones covered by fire, in front of obstacles, etc.

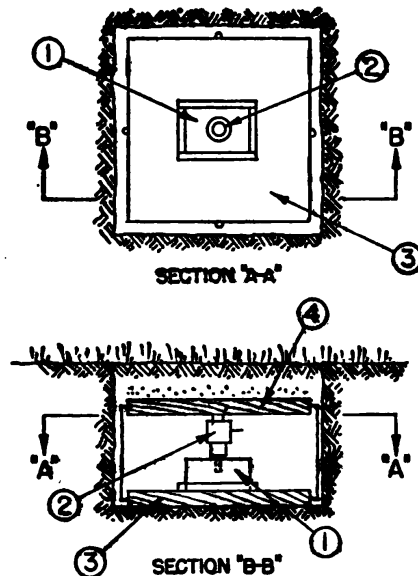

FIGURE 51.—Tretmine (tread mine).

c. Operation.—The mine is fired when sufficient pressure, applied by the passage of personnel, is transmitted to the top of the mine.

d. To disarm.—Locate the mine and neutralize the igniter. **Caution:** Care must be taken not to separate the planks (3) and (4) before the igniter is neutralized, since the igniter may also be attached as a pull igniter. Remove the igniter and the detonator from the charge.

e. To arm.—Set the igniter at the desired pressure. Install the detonator and igniter in the charge. Lead a long wire attached to the safety pin of the igniter to the outside. Fasten the pressure plank (4) to the sill plank (3) and lay the mine. Camouflage the mine by replacing the sod. From a distance, pull the safety pin out by means of the attached wire.

64. Brettstuckminen (board mines) (figs. 52 and 53).—The Brettstuckminen (board mines) are improvised antipersonnel mines. They are operated by pressure and may be equipped with antilifting devices. Two types of installation which are very similar are used when laying this mine.

a. Description.—The mine (fig. 52) consists of a charge (1) with a D. Z. 35 pressure igniter (2) (see par. 28) placed between two boards

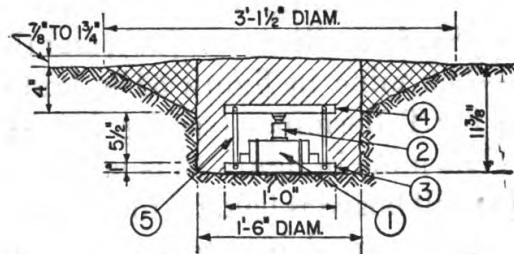

FIGURE 52.—Brettstuckmine (board mine)—installation 1.

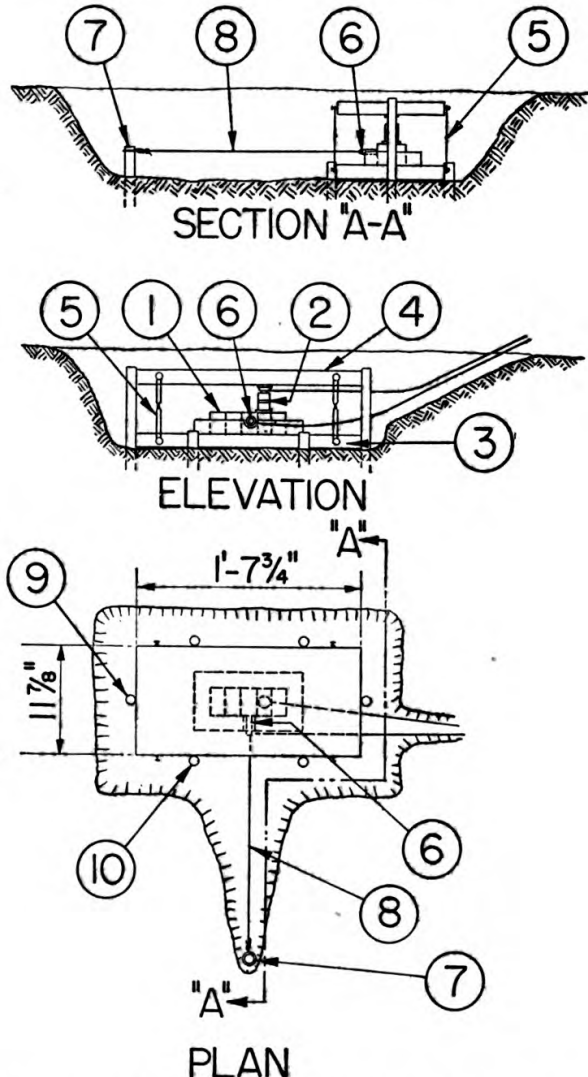

FIGURE 53.—Brettstuckmine (board mine)—installation 2.

(3) and (4) which are held in place by the wires (5). The charge may be a single charge of $2\frac{1}{4}$ pounds, a single charge of $6\frac{1}{2}$ pounds, or five prepared charges of 7 ounces each. When five prepared charges are used they are held in place by a frame mounted on the sill board (3). The pressure board (4) is spaced above the sill board by wood blocks which are removed when the mine is laid. A variation in the installation of this mine is shown in figure 53. It is the same as the above except for the addition of a pull igniter (6) connected to the stake (7) by means of the wire (8), four sill stakes (10), and the guide stakes (9).

b. Employment.—The mine in figure 52 is laid in a circular hole similar to that used for Tellermines (see fig. 22) except that the hole is 4 inches deeper. The mine in figure 53 is laid in a shallower trench, shaped as shown. The sill board is held by four stakes (10). At the end of the mine, two stakes (9) are driven to act as guides. A pull igniter may be employed as shown in figure 53.

c. Operation.—Pressure on the top board (4) forces the head of the pressure igniter down, setting off the detonator and exploding the charge. When the mine is equipped with the pull igniter (fig. 53), any attempt to lift the assembled mine or charge will operate the pull igniter by means of the pull wire (8) and explode the mine.

d. To disarm.—Carefully search for any pull igniters that may be installed. Neutralize any pull igniters and the main igniter and cut the wires attached to the igniters. Then cut the wires (5), and carefully remove the top board. Finally, remove the igniters and the detonators from the charge.

e. To arm.—Assemble the mine with the igniters and charge between the two boards (3) and (4), as shown in figures 52 and 53. With the spacer blocks holding the two boards apart, place the mine in the prepared excavation and connect any pull igniter to the stake. Lead the wires attached to the safety pins to the outside, remove the spacer blocks, and carefully cover the mine. Finally, withdraw the safety pins.

65. Druckbrettmine (pressure board mine) (fig. 54).—The Druckbrettmine (pressure board mine) is similar to the Brettstuckmine. The mine is operated by pressure and, as a variation, is also equipped with an antilifting device.

a. Description.—This mine consists of the two charges (1) with the pressure igniters (2) laid in a shallow trench with a cover board (3) resting across the heads of the igniters. Each of the charges is a $6\frac{1}{2}$ -pound prepared charge. However, if these are not available, each charge may be made up of three prepared charges of $2\frac{1}{4}$ pounds each or an assembly of fifteen prepared charges of 7 ounces each. When the charge is made up of several prepared charges, a

base board is required under them. The two charges may be connected by a detonating cord (not shown) to permit a simultaneous explosion in case only one igniter fires. The igniters fit into the top of each charge and are pressure operated, of the D. Z. 35 type (see par. 28). The wires (4) are connected to each igniter for the purpose of extracting the safety pin. The cover board is 4½ feet long and is held in place by the wires (5) which pass around the

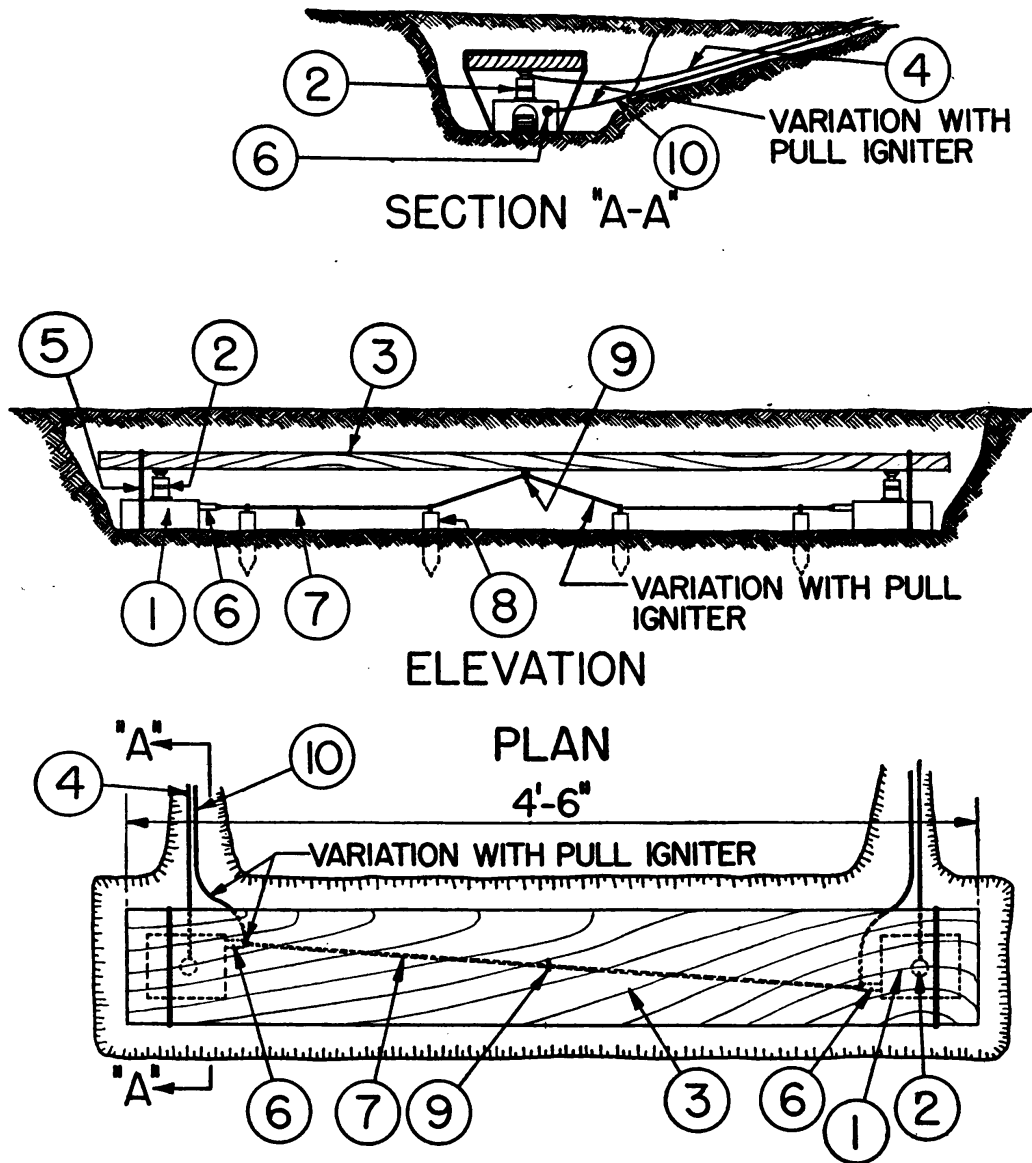

FIGURE 54.—Druckbrettmine (pressure board mine).

charge. The variation of this mine has a pull igniter (6) of the type Z. Z. 35 (see par. 26) installed in a side of each charge as shown and noted in fig. 54. These pull igniters function as an antilifting firing device. A pull wire (7), interconnected to the igniters, is threaded through the staples fixed in the heads of the stakes (8)

and is fastened to the underside of the pressure board (3) at (9). A wire (10) is connected to each igniter for the purpose of extracting each safety pin.

b. Employment.—The mine is used as an antivehicle mine. It is laid in a shallow trench about 4½ feet long and camouflaged.

c. Operation.—Pressure on the board (3) forces the heads of the igniters down, setting off their detonators and exploding the charges. When the mine is equipped with pull igniters, any attempt to lift the mine will cause the pull igniters to fire and explode the charges.

d. To disarm.—Remove the earth from over and around the mine, being careful to detect any pull igniters. Neutralize any pull igniters and cut the pull wire at each igniter. Then neutralize the pressure igniters. Cut the wires holding the cover board, and carefully remove the cover board. Finally, remove the igniters and detonators from the charges.

e. To arm.—Place the charges in a shallow ditch and attach the detonators and igniters, making certain that the safety pins are in place in the igniters. Place the cover board over the heads of the igniters and fasten it to the main charges by means of wires. If pull igniters are also used, connect the pull wire to the underside of the board as shown in figure 54. Now cover and camouflage the mine, making certain that the wires (4) and (10), attached to the safety pins of the igniters, lead out of the ditch. Remove the safety pins by means of the wires and from a safe distance.

SECTION X

BOOBY TRAPS

	Paragraph
General.....	66
Description.....	67
German employment of booby traps.....	68
Marking.....	69

66. General.—United States Army practice and British practice should be referred to in connection with variations of the use of booby traps. Generally, German booby traps may be antipersonnel or antivehicle. They consist of a prepared charge operated by a standard pressure (push) or tension (pull) igniter. The charge may be a standard prepared charge as described in section IV, chapter 2, a standard land mine assembly, or a specially prepared (improvised) charge. German troops are instructed as follows: "It should not be safe for him (the enemy of the Germans), when in an occupied community, to press a door latch, to move a wagon, to close a window,

to clear away debris, to disturb a wire, to cross a street, etc., without causing the explosion of a mine."

67. Description.—Booby trap charges are usually of tolite or TNT, a German explosive, and often consist of from two to eight tolite blocks, each measuring $2\frac{3}{4}$ by 2 by $1\frac{1}{2}$ inches, each weighing $3\frac{1}{4}$ ounces; cylindrical tolite cartridges, weighing $3\frac{1}{2}$ ounces are also used. Most of the igniters described in chapter 2, section II, have been used in conjunction with an explosive charge, to produce a booby trap. Booby traps may consist of an igniter screwed into an explosive block (petard), a shrapnel mine, or a Tellermine to form the charge. Antipersonnel mines such as the antipersonnel bounding mine (see par. 48) are well suited for employment as booby traps. Booby traps are frequently employed with Tellermines in the form of antilifting devices. The friction igniter Zdschn. Anz. 29 is then usually used to fire the trap as described in paragraph 23. The pull igniter Z. Z. 35, described in paragraph 26, is also used to fire Tellermines when set as a trap. The heavy antitank mine also employs the pull igniter Z. Z. 35 as a booby trap against lifting the lid (see par. 46).

68. German employment of booby traps.—*a. Employment of pull igniters as booby traps in buildings.*—In buildings, pull igniters inserted in prepared charges, or in egg grenades, explosive heads of stick grenades, or in Tellermines, and provided with trip wires, are commonly used as traps. The friction igniter Zdschn. Anz. 29, attached to prepared detonators, is also used with a short length of pull cord. The trip or pull wires may be laid across entrances and doorways, across stairways, or attached to doors of rooms or cupboards, or to windows. It is emphasized that careful search should be made before moving doors or windows of any building recently occupied by the enemy. Where any such wires or cords are found, they should be traced and the igniter neutralized as described in section II, chapter 2. Both ends of wires and cords must be investigated for traps; this is especially important where wires in tension are used to actuate the mines. The wire must *not* be cut until the method of firing the trap has been thoroughly investigated and the procedure for disarming established beyond all question of doubt. Booby traps employing pull igniters may also be attached to movable objects such as chairs, tables, etc., none of which should be moved until the search for traps has been made.

b. Employment of pressure igniters in buildings.—In buildings, pressure igniters are commonly found under loose boards placed in the path of entry. All loose boards are to be suspected and careful search made for pressure igniters. When found, the igniters should be neutralized and the charges removed. The D. Z. 35 (smaller ty

with light spring) and the Z. D. Z. 29 (set for light pressure) are the igniters usually employed for pressure firing of traps.

c. Traps encountered in the field.—Traps employing pull igniters are generally set along roads and in the field to catch the unwary or the inquisitive. The pull wires are often attached to a movable part of an abandoned vehicle or to the material forming part of a road barrier. In the latter case, the presence of the wires may easily be overlooked. Odd articles such as motor tires, gasoline tins, etc., lying scattered on the ground; sometimes conceal booby traps and should, therefore, not be moved until the trap has been found and neutralized. Wire fences and their pickets and notice boards also may have igniters and charges attached. Certain types of ammunition lend themselves readily to conversion into booby traps. The egg and the stick grenades, for example, can be rendered dangerous to use by the substitution of a short delay igniter in place of the usual type. British mines have been found to which the Germans have added antilifting devices.

69. Marking.—Booby traps are often marked with distinguishing signs, such as a swastika in colored chalk, left unintentionally by the Germans due to a rapid evacuation.

SECTION XI

MINE FIELDS

	Paragraph
General	70
Mine field lay-outs.....	71
German method of clearing mine field by use of exploding nets.....	72
Summary of German mine field practice.....	73

70. General.—The principles which guide the Germans in selecting a mine field location are essentially the same as our own. Maximum use is made of natural and artificial barriers to insure that approaching vehicles will be forced to cross the mine field. Roadways are usually mined at points where vehicles cannot detour, thus requiring extensive repair work before traffic can be resumed after vehicles have been demolished and the road cratered. Mines are used wherever it is desired to augment the difficulties of passage of natural or artificial obstacles. Extensive use is made of mines in preparing a hasty defense against counterattack. Under such conditions, because of lack of time for proper burial and concealment, the mines are generally laid on the ground surface until opportunity for burial and concealment presents itself. When the ground is covered with snow, land mines may not be buried until the melting of the snow makes conceal-

ment necessary. Although standard patterns for mine fields may be established in training pamphlets, there is considerable variation in the lay-out of German mine fields. The Germans leave gaps in mine fields for their own use, but normally they will place a small field about 50 paces behind the gap to act as a stopper. By the use of dummy mines, the Germans leave paths for the passage of their own vehicles. The Tellermine is normally used to form antitank mine fields. The heavy antitank mine is used for road blocks.

71. Mine field lay-outs.—*a. Spacing of contact mines in a defile.*—The mines are laid out in regular rows from a base line selected to tie into outstanding existing features which lie on the forward edge of the mine field. The interval between rows varies between 2 feet 4 inches and 5 feet. The number of rows is not fixed, but the mine field is designed to give a density of at least one mine to 14 inches of front. The mines are carefully concealed. An accurate record is kept of the extent of the mine field and of any gaps which may have been left for the Germans' own use.

b. Tellermine mine field patterns.—The measurements which establish the location of individual mines in a field are ordinarily made by pacing. Consequently, considerable variation from the intended pattern may be encountered. The spacing varies from 3 to 5 yards for "close spacing"; none are less than 2 yards apart. Spaced at 3-yard centers, the detonation of one mine will invariably detonate the one next to it. Tellermines are laid 10 yards apart for "open spacing." According to a captured German document, the distance between Tellermines, center to center, should be 5 paces (13 feet) when laid in the ground, or 10 paces (26 feet) when laid at the surface. In North Africa, mine fields of six rows have been found in which German Tellermines and Italian B-2 mines have been laid in alternate rows; individual mines were laid from 5 to 8 yards apart. These mines also have been found installed together in a haphazard manner throughout an entire mine field. In Cyrenaica, mine fields were found where Tellermines were laid on 9-foot centers. In one instance, the firing of one mine set off a row 980 yards long. An unsigned and undated German pamphlet on mine laying found in the Sudi Omar area, about November 24, 1941, gives the following patterns:

(1) *Hasty mine field.*—A lay-out for a hasty mine field is shown in figure 55. It has panels 30 paces across the front by 30 paces in depth, or approximately 80 by 80 feet. Each panel contains 12 mines. The resulting density is one mine for each 6½ feet of front, and thus would be classified as "open spacing." The panels are repeated side by side to cover the desired length of front.

(2) *Deliberate mine field.*—Lay-out for a somewhat more deliberate type of mine field is shown in figure 56. This is also "open spacing." The panel is 30 paces across the front by 40 paces in depth, or approximately 80 by 105 feet. It contains 24 mines, giving a density of one mine per meter ($3\frac{1}{4}$ feet of front). These panels are combined to form staggered patterns of three panels each. Each panel is offset 20 paces ($52\frac{1}{2}$ feet) from the adjacent panels, as shown in figure 57. These patterns of three panels each may be further combined to form a more extensive mine field lay-out. (See fig. 59.)

(3) *Variation of deliberate mine field.*—The variation of this more deliberate mine field is a panel, having "close spacing," 15 paces across the front by 40 paces in depth, or approximately 40 by 105 feet. It contains 24 mines, giving a density of two mines per meter ($3\frac{1}{4}$ feet) of front. These panels are normally combined in groups of three in echelon arrowhead forward, or arrowhead reverse formation as shown in figure 58. These groups of three panels each are further combined to form large mine fields or a part of an extensive lay-out as shown in figure 59.

(4) *Extensive mine field.*—An extensive mine field lay-out (fig. 59) may combine groups of open-spaced and close-spaced panels. A minimum distance of 50 paces (131 feet) between fields is maintained.

NOTE.—There is a disagreement between the captured text and its illustrations. In preparing this manual it has been assumed that the illustrations, rather than the captured text, are correct.

(5) *Road blocks.*—Tellermines may be used in road blocks alone or in conjunction with artificial barriers. The interval between mines is about 1 pace ($2\frac{1}{2}$ feet) and slightly less than this between rows. Thus four rows, as shown in figure 60 (mined road), give a density of one mine to each $7\frac{1}{2}$ inches width of roadway. When the Germans mine a road, yet continue to use it for their own needs, one-half of the road width is left unmined. Detours which the Germans have used to bypass their own road blocks may be heavily mined when the area is given up to the advance of the Germans' enemy. If the nature of the road surface permits, mines are buried. Mines are sometimes laid indiscriminately on the shoulders of the roads. In North Africa, tracks leading out of towns have been mined as shown in figure 60 (track block and mine field). Other road blocks have been found where mines were laid in a few "chuck" holes in the roads, the remainder of the holes being empty. Of course, all had to be carefully examined. For 10 kilometers south of Agedabia, road blocks were laid at each kilometer stone which was used as a marker.

(6) *Mine field records.*—Mine fields are mapped on a scale of 1:2,500 and the complete scheme transferred to a 1:10,000 map.

(7) *Marking.*—Mine fields laid in advance of an enemy approach are marked by holes, sticks, branches, or wires as warning to the Germans' own troops. A report of a mine field at Ben Temrad states that mines are laid at very irregular spacing, but always in or near a vehicular track. The mines laid across the vehicular tracks are generally marked with small stone cairns at the corners of the fields. Mines are also laid along tracks, and these seem to be marked by cairns at either end of the mined sections.

c. Heavy antitank mine fields.—The German heavy antitank mine discussed in paragraph 46 is normally used to form antitank road blocks on main lines of communication. The road blocks formed by these mines usually contain between 15 and 20 mines laid in one of two patterns as follows:

(1) In a line diagonally across the road, 20 mines occupying about 100 yards of the road.

(2) In a checkerboard pattern with the mines placed $6\frac{1}{2}$ to 8 feet apart and each row of mines covering the gaps of the preceding row. The depth of the mine field may be 15 to 20 yards or more. In some cases Tellermines have been found mixed with heavy mines.

d. Antipersonnel mine fields.—The antipersonnel mines are placed in fields and are on occasion very precisely located by means of standard lay-out equipment. This equipment consists of an equilateral triangle made up of ten rings, each $15\frac{3}{4}$ inches (40 cm.) in internal diameter, and 18 cords, each 14.43 feet (4.4 meters) long (see fig. 61). Each side of the triangle formed by the joining of the cords and rings is, therefore, 43.3 feet long and is made up of three cord lengths and four rings. The triangle is laid out on the ground with one edge along a base line, and an antipersonnel mine is planted in each ring. The triangle is then turned through 60° about the corner of the triangle farthest from the base line, and more mines are laid at each ring (see fig. 62). This procedure is repeated to form some such continuous field as shown in figure 61. The field as shown is located by extending the base line for 328 feet (100 meters) away from the enemy and marked with pickets at 65.6-foot (20-meter) intervals (points P1, P2, P3, P4, P5, and P6), except that for safety the point P6 is set back 6.6 feet (2 meters) from the corner mine, making the interval from P5 to P6 only 18 meters. The point P1 is tied into two reference points HP₁ and HP₂, and the azimuth of the extended base line P1 to P6 is recorded.

72. German method of clearing mine field by use of exploding nets.—The exploding net is a grid made of detonating fuzes (detonating cord or primacord in our Army) in square mesh 5.9 inches (15 cm) on a side. The standard size of the net is 33 feet (10 m) long

and 8 feet (2.5 meters) broad, although nets of larger size can be made by supporting them on frames of laths. Where the detonating fuze lengths cross, they are tied securely with thin steel wire. The fuze must not be kinked. When rolled, the standard net has a diameter of about 8 inches (20 cm) and weighs about 19.8 pounds (9 kg). Although one man can carry two of these nets, two men are required for unrolling and laying. Where more than one net is used, a lap of 3.9 inches (10 cm) between adjacent nets is provided, and they are tied together. These nets are said to be sensitive to artillery fire, bombing, and shrapnel. German instructions state that, in open country, nets must be laid down under cover of darkness or mist, and the time between laying and exploding must be reduced to a minimum to prevent premature demolition by fire and preserve the element of surprise. There are many practical difficulties in the use of the exploding net in the field, since the ground must be sufficiently clear of obstructions to permit the placing of the nets. Shrubs, stones, and other objects easily kink and break the detonating fuze and prevent its being laid in close contact with the ground. Since action of the detonating fuze depends on the efficiency of the blast pressure wave it is necessary, if it is to detonate all mines underneath it, that it be as close as possible to the mines. There can be no guarantee that all mines will detonate.

73. Summary of German mine field practice.—The following conclusions are drawn from German experiences with mine fields:

a. Mine field lay-out plans.—Accurate mine field plans are extremely important, since the unit employed in laying the land mines may not be the one to take up the mines.

b. Mine field reports.—Prompt reports accompanied by lay-out plans of all mine fields should be submitted to designated higher authority, to facilitate the publication of adequate warning in order to prevent losses of men and vehicles in their own mine fields.

c. Temporary nature of mine fields.—Mine fields should always be viewed as temporary, to be taken up again as our own troops advance. For this reason it is desirable to continue the troops engaged in land mining in the area where they perform such duty so that they may be employed in the removal of the mines they themselves set out.

d. Mine fields behind water obstacles.—In planting a mine field behind a water obstacle the mines should be laid close to the edge of the water. If mines are located several yards back, it is possible for the enemy to land personnel skilled in the neutralization of land mines.

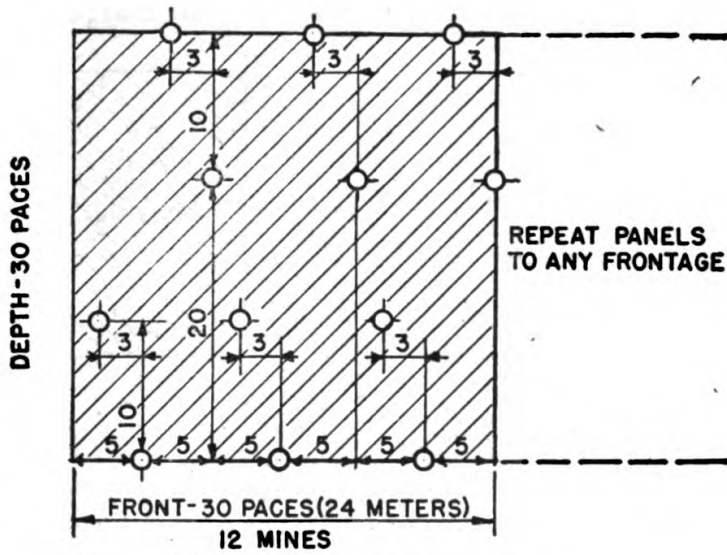

NOTE: 10 PACES = 26 FEET = 8 METERS

FIGURE 55.—German hasty mine field pattern (open spacing).

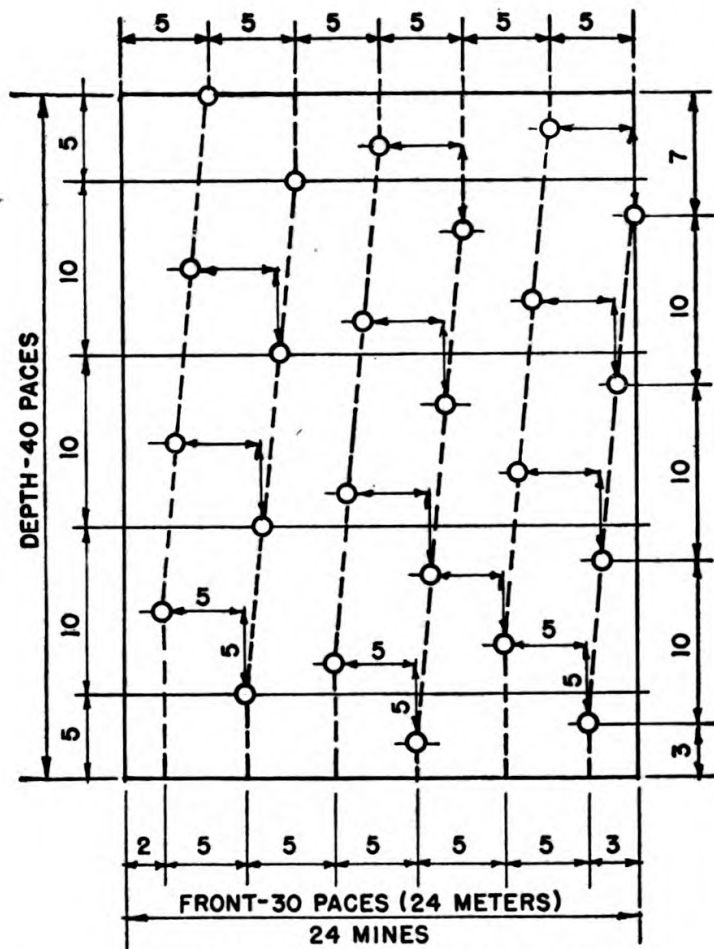

NOTE: 10 PACES = 26 FEET = 8 METERS

FIGURE 56.—German deliberate mine field pattern (open spacing).

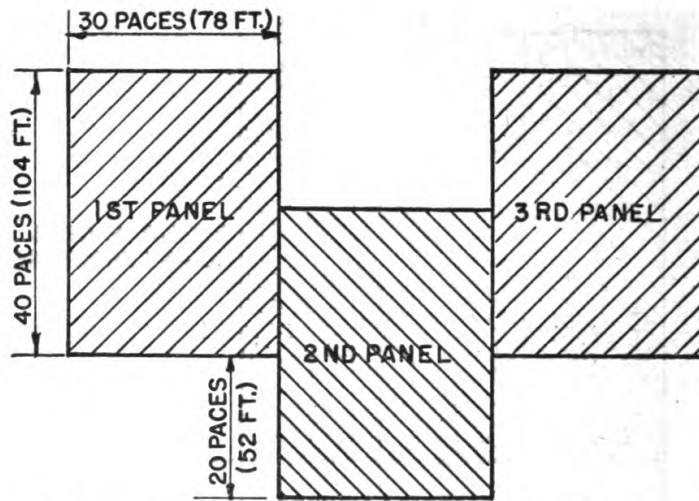

FIGURE 57.—Panel arrangement of German deliberate mine field.

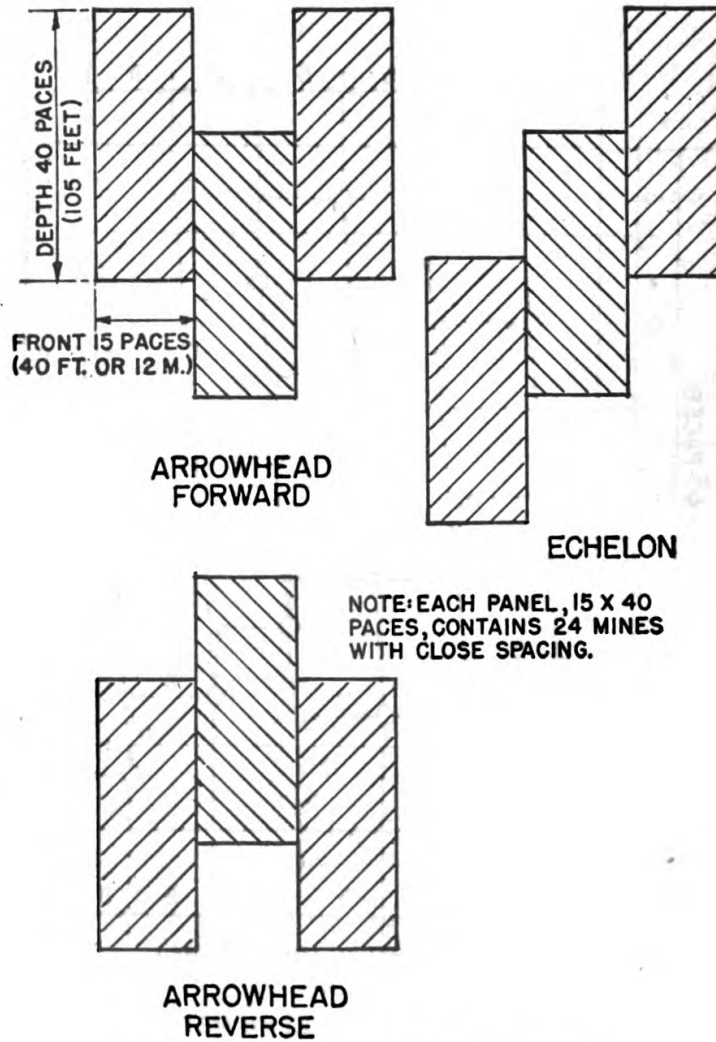

FIGURE 58.—German panel mine fields.

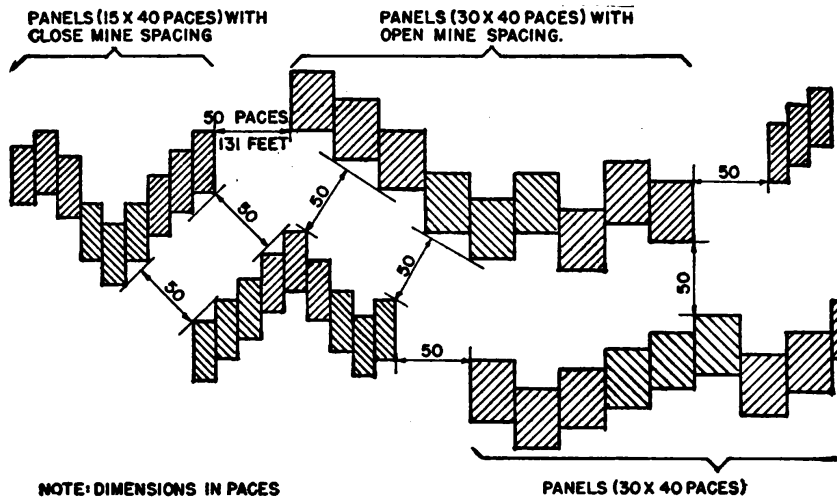
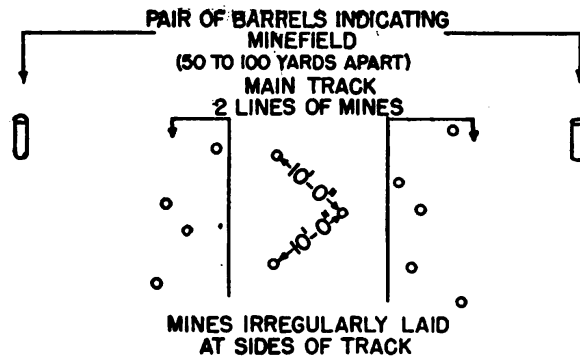

FIGURE 59.—Lay-out of German mine fields.



TRACK BLOCK AND MINEFIELD

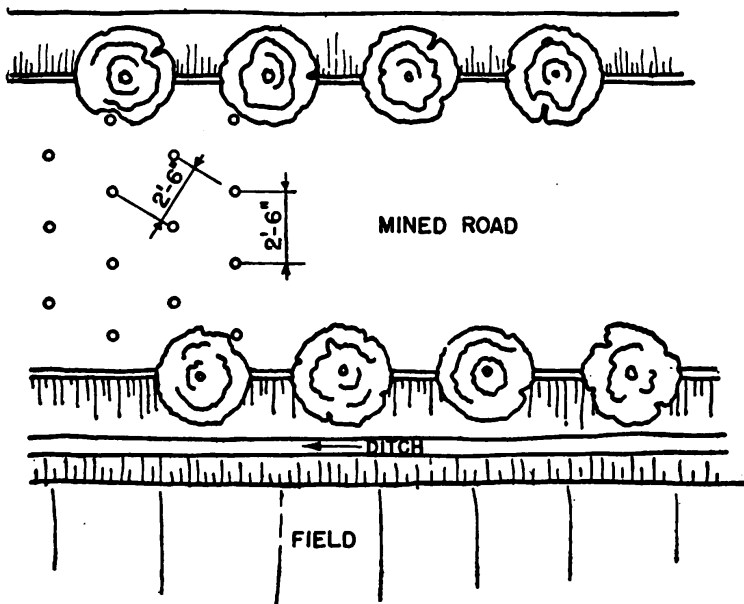

FIGURE 60.—Tellermine road and track blocks.

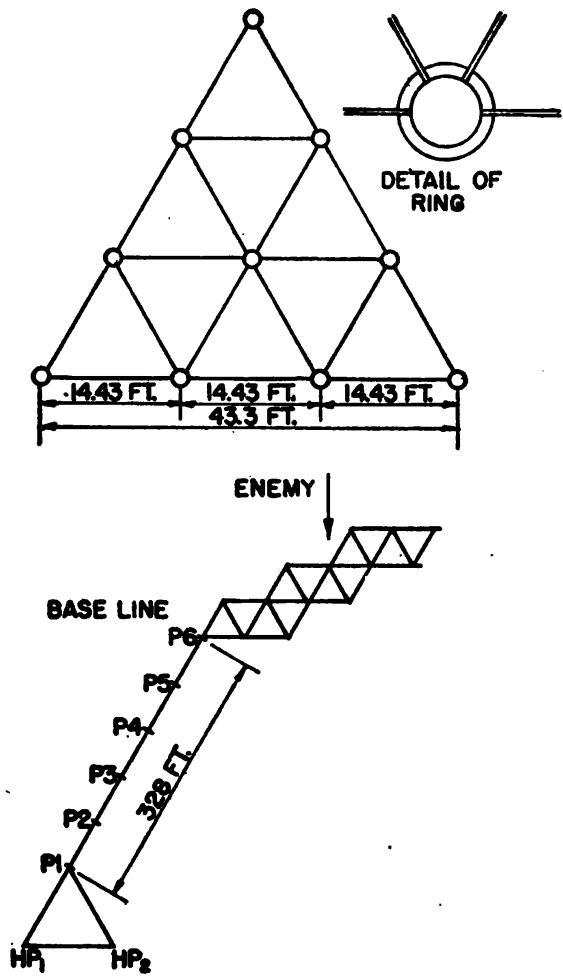

FIGURE 61.—Equilateral triangle method for laying out antipersonnel mine fields.

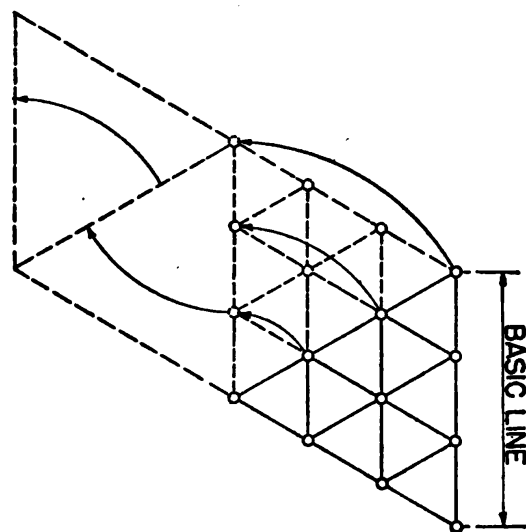

FIGURE 62.—Method of rotating equilateral triangles for antipersonnel mine fields.

CHAPTER 3

ITALIAN LAND MINES

	Paragraphs
SECTION I. General	74-75
II. Antitank mines.....	76-87
III. Railway mine.....	88
IV. Antipersonnel mines	89-93
V. Dual purpose mine.....	94
VI. Booby traps	95

SECTION I

GENERAL

	Paragraph
General.....	74
Types of mines.....	75

74. General.—In general, the Italian land mines are very different from the German land mines. The Italian mines with few exceptions are characterized by their long, narrow, box-like appearance, and their assemblies are all quite similar. The antitank mine, type D and the land mine, railway type have some resemblance to the German Tellermines. The Italians also make use of electrically fired mines. The principal characteristics of the Italian mines may be summarized as follows:

a. Unlike the German practice of using standard igniters, each Italian mine has a special igniter to fit the individual mine.

b. No recesses for secondary firing devices, like those common to the German Tellermine, are provided. However, supplementary booby traps may be attached in other ways, especially on the lid of the mine.

c. The detonators are not standardized to the extent of the German mines. Some of the detonators, particularly in antitank mines, are improvised from cartridges.

d. Instead of standardizing their mines, the Italians are disposed toward improvised mines, and they often employ standard munitions in their assemblies.

75. Types of mines.—Up to the present, Italian mines encountered may be grouped as follows:

- a. Antitank mines.
- b. Railway mines.
- c. Antipersonnel mines.
- d. Dual-purpose (antitank and antipersonnel) mines.

SECTION II

ANTITANK MINES

	Paragraph
Type N-5.....	76
Type B-2.....	77
Type B-2 S. C. G. model.....	78
Type B-2 (hinged lid).....	79
Type 9, pressure operated.....	80
Type N, improvised.....	81
Type D.....	82
Electric mine, type 2.....	83
Improvised mine employing HE (high explosive) shells.....	84
Land mine, metal tube.....	85
Pressure mine with grenade exploder.....	86
Circular variable pressure mine.....	87

76. Type N-5 (figs. 63 and 64).—This mine appears to be an improvement over the Italian antitank mine, type B-2, described in paragraph 77. It is normally employed as an antitank mine, but it may also be used as an antipersonnel mine by adjusting the operating pressure to a minimum of 22 pounds. The sensitivity of this mine to blasts is uncertain, but one report indicates that it probably is quite insensitive in this respect.

a. *Description.*—The mine is rectangular in shape and is made of mild sheet steel. When assembled, the mine measures 2½ inches in width, 2¾ inches in height, and 45 inches in length, and weighs 17 pounds. The body of the mine is a metal box (1) which contains the explosive, detonators, and igniter assembly. It has a metal cover (2) which is supported by and houses the upper part of two pressure-operated releases. There are two identical igniters, one in each closed chamber (3) at each end of the box. The space (4) between the igniter end chambers contains the explosive. A more detailed description follows:

(1) *Explosive.*—The explosive consists of 13 blocks of a high explosive (HE) having a total weight of approximately 5 pounds. Each block is hard and red in color, resembling common carbohc soap. It measures approximately 1½ by 2 by 2½ inches, and is 50 percent TNT and 50 percent penthrite. This charge is more sensitive than

pure TNT, and when placed on a steel plate it can be made to detonate by a sharp blow from a hammer. Upon complete detonation it has a great shattering effect with very little smoke. It is easily ignited by a flame or red hot iron and burns brightly, giving off some black smoke, but much less than TNT. Each end block (5) (primer or primer charge) of the explosive has a prepared hole, approximately $\frac{1}{4}$ inch in diameter and $1\frac{1}{4}$ inches deep, to receive the closed end of the detonator (6). The projecting open end of the detonator enters the bored hole (7) in the end of the striker body (8).

(2) *Igniter*.—Since the two igniters are identical, the description of one will satisfy for both. The igniter assembly is contained in a metal striker body (8), and consists of a percussion cap (9) in a metal holder (10), and a striker mechanism. The striker mechanism is made up of a striker (11), a striker spring (12), a striker retaining nut (13), and a striker cocking grip (14). The metal igniter body (8) is irregularly shaped and is bored and machined to receive a pressure-operated assembly as well as an igniter assembly. The igniter body is placed in the end chamber so that the detonator projects through the chamber partition into the explosive space (4), and the opposite end of the igniter body (1) projects through the end of the mine box. Near its outer end, the body is enlarged to rest on the bottom of the chamber and is secured to the bottom of the igniter body with the screw (15). The cap holder fits through a recess in the side of the mine box into a recess (16) in the striker body so as to position the head of the percussion cap toward the striker. The spring clip (17) engages the holder (10) in the V-groove (18), so as to position and hold it in place. The grip is used to cock the striker by pulling it outward against the compression of the spring until the striker release pin (19) fits in front of the flanged striker head (20) near the striker point. The striker release pin is held in position by a retaining spring (21), which is secured to the body by the screw (22). During the cocking operation, the face (23) of the grip bears on the striker flange (24). After cocking the striker, the grip is pushed in so that face is in contact with the retaining nut. With the grip in this position, a hole (25) which receives a safety pin (26) will be visible in the end of the striker. When the safety pin is inserted in the hole, the striker is prevented from moving forward. When the safety pin is removed, the striker is held only by the striker release pin.

(3) *Pressure-operated releases*.—Each release consists of a plunger mechanism which transmits pressure to an actuating pin (27) which, in turn, depresses the U-shaped spring clip (28) attached to the striker holding pin (19). By this means, downward pressure on the mine cover moves the striker holding pin down against the upward pressure

of the retaining spring, and releases the striker. The parts of the assembly are shown in detail in section A-A, figure 63. The plunger mechanism has a bolt-shaped plunger (29), which has a sliding fit through the two-piece collar (30), attached to the top of the mine box. A helical spring (31) fits over the plunger and is held in position by a conical nut (32). The mine cover fits over the nut and is secured to the plunger by a second conical nut (33). The actuating pin fits through a hole in the side of the mine, and its lower arm bears against the splayed end of the U-shaped spring clip. This spring fits around

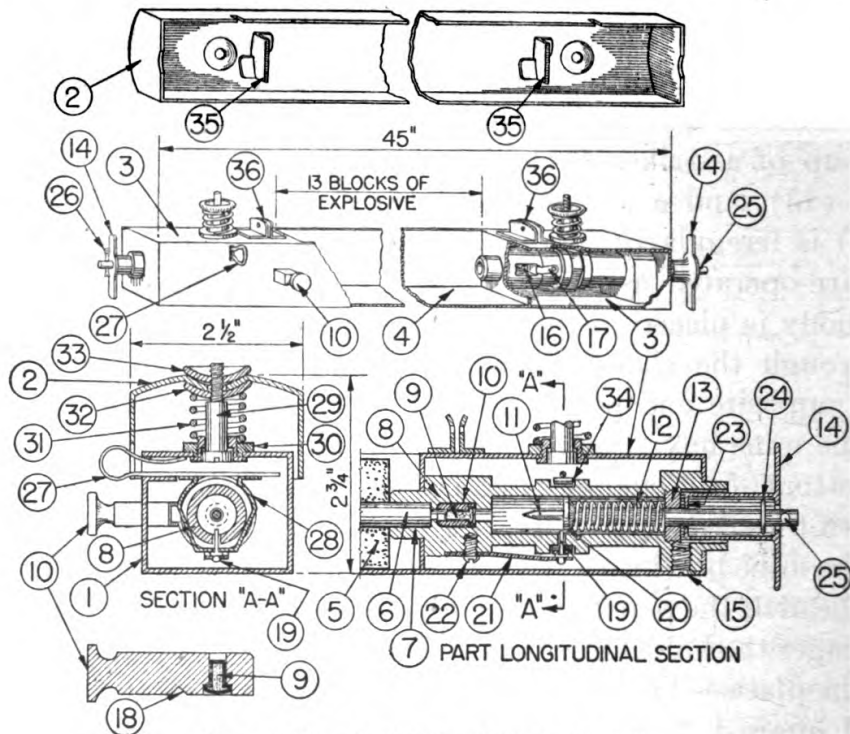

FIGURE 63.—Antitank mine, type N-5.

the igniter body in the groove (34), and its lower end bears on the flanged part of the striker holding pin.

(4) *Pressure control shear pin device.*—This device consists of two small steel knives (35) welded to the underside of the cover, and two guides (36) made of light sections of steel angles welded to the top of the mine box directly below the knives. A copper shear wire is inserted in the holes of the guides. This wire is a No. 14 gage, or $\frac{1}{16}$ inch in diameter. When pressure on the mine cover moves the cover down, the knives ride in the guide and shear the wire. The purpose of the device is to add to the resistance to the downward movement of the cover so that the mine will fire only under such heavy loads as that of tanks.

b. Employment.—Usually, the mines are laid in two rows, and no case has been encountered where more than three rows have been

employed. The large distributed earth pattern of the rectangular excavation for the mine makes the mine relatively easy to detect. A lay-out of an Italian mine field which uses this mine, set to operate as an antitank mine in conjunction with B-4 antipersonnel mines, is shown in figure 64. Reports point out that booby traps are sometimes used in connection with this mine.

c. Operation.—When used as an antitank mine, the weight of the tank forces the cover downward, shearing the wire in the guides. At the same time, the downward pressure of the cover compresses the helical spring, and the plunger moves down. When the plunger reaches the actuating pin, the downward movement is transmitted to the U-shaped spring clip. In turn, the spring clip forces the striker holding pin outward against the action of the retaining spring, and frees the

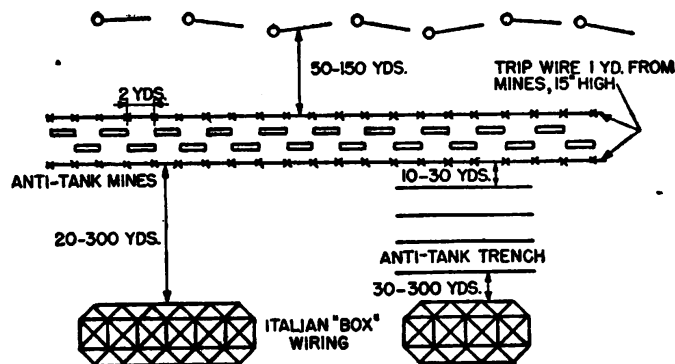

FIGURE 64.—Italian mine field at Tobruk.

striker. The striker, under the pressure of the striker spring, is propelled forward against the percussion cap, which fires the detonator and explodes the mine. When used as an antipersonnel mine, the shear wires in the guides are left out.

d. To disarm.—Using care to avoid pressure on the top of the mine cover, first neutralize the mine as follows: Insert a nail or piece of stout wire in the safety pin hole in the end of each striker. It may be necessary to manipulate the grips before these holes become visible. Next, withdraw both actuating pins from the side of the mine and remove both cap holders from the striker body, easing the pressure from the spring (17) if necessary. The cap holders may be a little difficult to remove if the springs are strong. If the mine is not to be reused, remove the percussion caps from the cap holders. To disarm the mine completely, continue in the following order: Unscrew the nuts (33) and remove the cover. Finally, remove the detonators from each explosive block (primer) (5). If the mine is not to be reused, reassemble the mine without the percussion caps or detonators.

e. To arm.—To arm the mine, proceed in the following order: Withdraw the actuating pins and the cap holders, and then remove the mine

cover. If the mine is to be used as an antitank mine, insert the copper shear wires in the guides. Adjust the compression in the helical spring to suit the pressure requirement for antitank or antipersonnel use by screwing the nut (32) up or down. If the nut is screwed down, the compression in the spring is increased and a higher pressure is required on the mine cover to discharge the mine. Conversely, if the nut is screwed upward, the compression in the spring is decreased and less pressure is required to discharge the mine. Consider the weight of the earth cover to be placed over the mine when adjusting the compression in the spring. After this adjustment, cock both strikers and insert safety pins in the holes. Then remove the two end explosive blocks (primers), insert detonators with closed end inwards in the prepared hole, and replace each block in position in the mine. Insert the open end of the detonator into the opening in the igniter body. Next, replace the mine cover, screwing down the nuts finger tight, and insert the actuating pin as shown in section A-A, figure 63. Then place the percussion cap in the cap holder and insert the cap holder in the opening (16) so that the spring engages the V-groove. Camouflage the mine as necessary, and withdraw the safety pins from a distance by means of attached wires. If the mine is laid as an antipersonnel mine, the copper shear wires should not be used, and the weight of the camouflage layer should be considered in adjusting the compression in the spring.

77. Type B-2 (figs. 65 and 66).—Available information on this Italian antitank mine indicates it is inadequately sealed against moisture, and therefore is unsuitable for use in damp soils or after prolonged exposure to the elements. Immersion in water renders the mine completely ineffective. The mine is too heavy and bulky for the amount of explosive it contains and the damage that it can produce. Available information is in conflict as to the pressure required to fire this mine, being either 300 or 440 pounds. The British are undertaking trials to ascertain the required firing pressure for this type of mine. It is stated in a report dated March 2, 1942, that up until that time, no booby traps had been found installed in this mine. Variations in construction of this mine have been found.

a. Description.—This mine is a welded sheet steel rectangular box (1) with a detachable cover (2). The cover is supported by the springs (4) and is held in place by small chains (3) at each end. When assembled, the mine measures 5 inches in width, 5 inches in height, and 42 inches in length, and weighs approximately 33 pounds. The box contains two springs (4), the explosive (5), the firing circuit consisting of two cordtex fuzes (6) and (7), and the igniter with its actuating devices. At each end of the box is located a wooden compartment (8) which contains the explosive. Photo-

graphs show one variation of this mine in which the wooden tops and interior end walls of these compartments were omitted. The bottom of the remainder of the box is built up with wood to seat the igniter and its actuating parts. The springs are held in tubes (10) fixed to the underside of the cover, fit into the inside of the springs, and hold them in position. The igniter with its actuating devices is located centrally in the mine box. Above the igniter assembly in the cover are two hinged lids. (11) and (12) to permit access to the detonators and arming devices. A more detailed description is as follows:

(1) *Explosive and firing circuit.*—The total charge weighs about 8 pounds and consists of eight blocks of explosive in each wood compartment. The blocks are probably TNT. A percentage of these blocks has a prepared hole to accommodate a detonator. One of the blocks with a hole in each compartment is positioned to receive the detonating end of the firing circuit. The two cordtex fuzes, which constitute the firing circuit, connect the igniter to a detonator inserted in each charge, and permit the igniter flash to detonate both charges simultaneously. A Military Intelligence report received January 15, 1942, states that a double-ended detonator is placed in the hole (17) of the firing assembly which also receives the fired end of the cordtex fuze (6). Additional detonators are placed in the recesses in the blocks of the two charges which receive the firing ends of the two branches of the cordtex fuze (6) and (7).

(2) *Igniter and actuating devices.*—The igniter is shown in detail in figure 66 and has a cast metal body (13) which is secured to wood blocking below. The igniter body is bored and machined to receive a striker (14), a striker spring (15), and a striker retaining collar (16). The other end of the body has a bored and machined hole which receives the double-ended detonator and the cordtex (6), which is secured by a knurled screw collar (18). The igniter body is recessed at (19) as shown in sections A-A and B-B to receive a cap holder (20) containing a percussion cap (21). The striker is cocked by turning the knurled screw (21a), which screws on an eye bolt (22) connected to the striker by the wire (23) which is stated to be copper. The eye bolt and knurled screw are supported by a bracket (26) which is secured to the bottom of the mine box. In the cocking operation, the striker is pulled outward, compressing the striker spring, until the striker holding pin (24) drops in front of the flanged head (25) of the striker. The pin is actuated by and connected to a lever (27) and passes through a hole (28) in the top of the striker body (13) as shown in Section C-C, figure

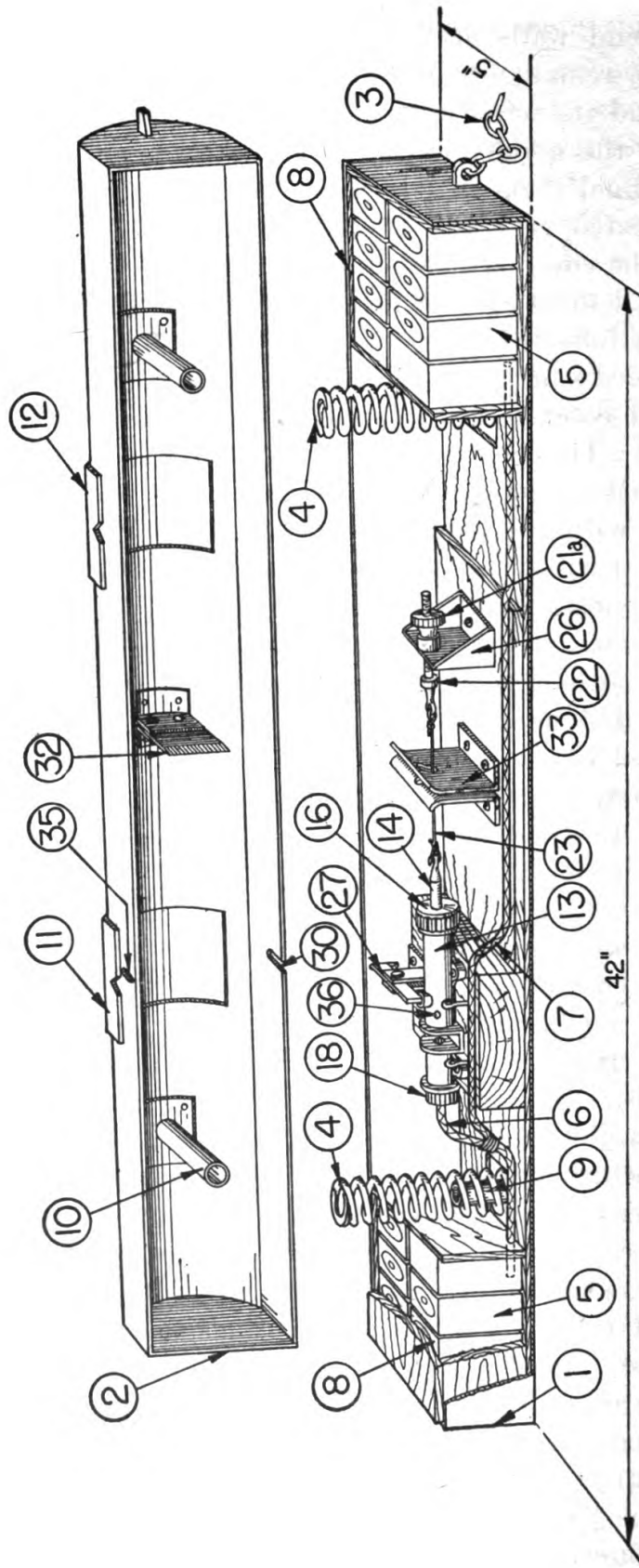

FIGURE 65.—Antitank mine, type B-2 (assembly).

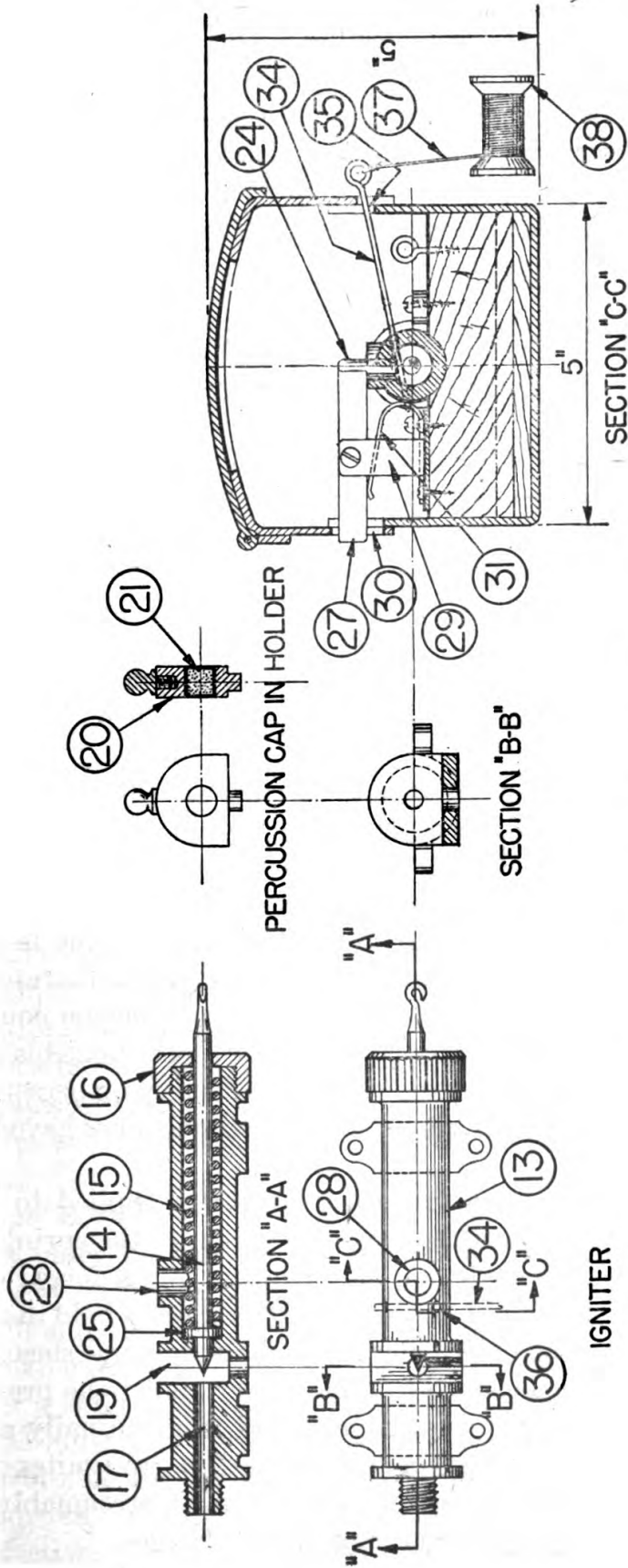

FIGURE 66.—Antitank mine, type B-2 (details).

66. Lever is pivoted on a bracket (29), which is supported by the base support for the igniter assembly. The exterior end of the lever projects through a slot (30) formed in the top edge of the box, just far enough to be engaged by a similar slot formed in the bottom edge of the cover when the cover is depressed. The pressure of a spring (31) bearing on the lever tends to force the pin into the recess (28) in the body and in the path of the striker. The lever may be used either as a safety device during the arming of the mine, or as the initial release of the striker when the mine is fired. A device to hold the striker against accidental release is provided by a pin (34) which extends through a slot (35) in side of the mine and is inserted in holes (36) in the igniter body. In the event of accidental release of the lever or breaking of the wire (23) during arming, the safety pin (34) will prevent the striker from detonating the percussion cap. A spool (38) of cord (37), which is attached to the safety pin, is provided for removing the safety pin from a safe distance. The striker is released by a knife blade (32) mounted on the inside of the cover, which shears the wire (23). The wire passes through holes in a cutter guide (33) mounted on the wood firing assembly base. The holes hold the wire when the blade shears the wire.

b. Employment.—These mines are frequently placed in front of, or in the gaps of, antitank obstacles. They are also used to mine possible detours. The spacing between the mines varies considerably. They are usually laid in one or two rows, but never more than three rows have yet been encountered. It appears that this mine is capable of inflicting only minor damage to a tank, and should therefore be considered a light antitank mine. At most, the explosion could cut the tank treads. The charges are too small to cause serious blast effect on the belly of the tank or damage to the machinery or personnel inside the tank. No case has been reported where these mines have been fitted with booby traps.

c. Operation.—When downward pressure is applied to the cover, the cover moves down against the compression of the springs. As the cover moves down, the exterior end of lever (27) is forced downward and the striker holding pin moves upward to free its hold in the striker. At the same time, the cutter rides into the guide and shears the wire (23), thus releasing the striker. The striker, under the pressure from the compressed striker spring, is propelled longitudinally against the percussion cap. The flame from the percussion cap ignites the instantaneous fuzes (6) and (7) and explodes the mine, presumably by means of a detonator incorporated in the prepared charges.

d. To disarm.—Although secondary activating devices have not been reported installed in this mine, the possibility should be considered. Neutralize the igniter by inserting a safety pin or stiff wire through the slot (35) in the side of the mine and into the hole (36) in the igniter body. To perform this operation with a clear view, open the lid (11). Then proceed to disarm the mine in the following order: Release the chains at the end of the mine and remove the cover. Remove the cap holder and extract the percussion cap. Unscrew the fitting (18) and remove the end of the cordtex fuze (6) and the double-ended detonator from the igniter. Finally, uncock the striker by backing off on the knurled thumbscrew until the compression in the striker spring has been released, and replace the mine cover.

e. To arm.—To arm the mine, two methods may be followed. In the first, open the two lids (11) and (12) of the cover and proceed as follows: Depress the lever (27) so as to raise the holding pin sufficiently to permit the igniter flange free movement past the hole (28). Cock the striker by taking up on the knurled thumb-screw until the striker is locked by the striker holding pin through the action of the spring on the lever. Next, insert the safety pin into the hole in the igniter by passing it through the slot (35) in the outside of the mine. Then insert the end of the instantaneous fuze (6) into the opening (17) of the igniter and secure by screwing up the fitting (18). Now place the percussion cap in the cap holder, and insert into the recess of the igniter. Finally, close the lids (11) and (12), cover the mine with earth, and withdraw the safety pin from a distance. In the second method of arming the igniter, after the preliminary steps are taken, turn the knurled thumbscrew until the pin locks the striker. Then release the tension in the wire (23) by turning the thumb screw slightly in the opposite rotation. Then trip the lever (27) and the pin (24) out of engagement with the striker. In this method, the striker is held only by the wire (23). Continue arming as described for the first method.

78. Type B-2, S. C. G. model (figs. 67 and 68).—This Italian mine is an older type of the antitank mine B-2 described in paragraph 77 and is similar to it in many respects. It differs from the more recent models of type B-2 principally in the fact that it contains a smaller explosive charge, has a simpler igniter, is not provided with a safety device, and has only one hinged opening in the cover. The mine is inadequately sealed against moisture, and therefore is unsuitable for use in damp soils or after prolonged exposure to the elements. Complete immersion in water shortly renders the mine ineffective. The mine is also much too heavy for the amount

of explosive it contains and the damage that it can produce. These comments are further clarified in the following:

a. Description.—This mine is a welded sheet steel rectangular box (1) with a detachable cover (2). The cover is supported by the springs (4) and is held in place by an L-shaped hook (3) at each end. When assembled, the mine measures approximately 5 inches in width, 6 inches in height, and 42 inches in length, and weighs approximately 31 pounds. The box contains two springs, the explosive (5), the firing circuit consisting of two cordtex fuzes (6) and (7), and the igniter with its actuating devices. At each end of the box is located a wooden compartment (8) which contains the explosive. The bottom of the remainder of the box is built up with wood to seat the igniter and its actuating parts. The springs are held in place by a short length of steel tube (9) fixed to the metal bottom

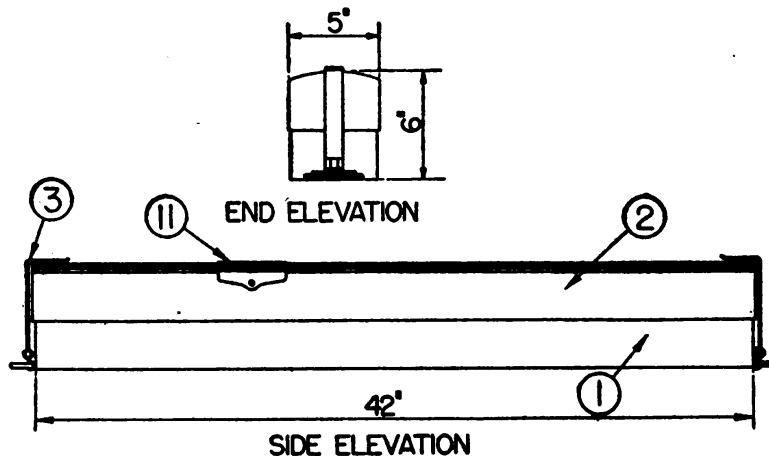

FIGURE 67.—Antitank mine, type B-2, S. C. G. model (elevations).

of the box. When the cover is in position over the mine box, similar steel tubes (10), fixed to the underside of the cover, fit into the inside of the springs and hold them in position. The igniter with its actuating device is located centrally in the mine box. Above the igniter in the cover is a hinged lid (11) to permit access to the igniter. A more detailed description is as follows:

(1) *Explosive and firing circuit.*—A charge of TNT, weighing about $6\frac{1}{2}$ pounds, is placed in each compartment. These explosive blocks generally have a hole to receive a detonator; one of the blocks with a hole is positioned to receive the detonating end of the firing circuit. The two cordtex fuzes (6) and (7), which constitute the firing circuit, connect the igniter to a detonator inserted in each charge, and permit the igniter flash to detonate both charges simultaneously. The Middle East Training Pamphlet, part IV, issued April 1942, states that "this mine is similar in some respects to the

mine, type B-2." The type B-2 mine is described in paragraph 77. It is probable that in the type B-2 mine the detonator is used to fire the cordtex fuze (6) and its branch (7).

(2) *Igniter and actuating devices.*—The igniter is shown in detail in section "A-A", figure 68. It has a cast metal body (12), which is secured to wood blocking, fastened to the base of the box by two collars (13). The igniter body is bored and machined to receive a striker (14), a striker spring (15), and a striker retaining collar (16). The other end of the body has a bored hole which receives an adapter (17) which holds the double-ended detonator and the fired end of the cordtex fuze (6). The igniter body is recessed at (18), as shown in section A-A to receive a cap holder (19) containing a percussion cap (20). Access to the percussion cap holder can be had through the access hatch door (11) in the cover. The striker is cocked by turning the wing nut (21) which bears on the nut (22) and screws on a hook screw (23). The nut bears on the angle (25) which is secured to the bottom of the box. The hook screw is connected to the striker by the wire (24). In the cocking operation, the striker is pulled outward, compressing the striker spring (15). In this position, the striker is held only by the tension in wire (24). A striker release device which cuts the wire to release the striker is made up of the cutter (26) and the cutter guide (27). The cutter has a knife edge and is secured to the cover of the mine. The cutter guide is secured to the bottom of the mine box and has holes through which the striker holding wire (24) is threaded and which holds the wire where the blade (26) shears the wire.

b. Employment.—These mines are frequently placed in front of, or in the gaps of, antitank obstacles. They are also used to mine possible detours. The spacing between the mines varies considerably. They are usually laid in one or two rows, but never more than three rows have been encountered. It appears that this mine is capable of inflicting only minor damage to a tank, and should therefore be considered a light antitank mine. At most, the explosion could cut the tank treads. The charges are too small to cause serious blast effect on the belly of the tank or damage to the machinery or personnel inside the tank. No case has been reported where these mines have been fitted with booby traps; however, this is a distinct possibility. A particularly vital spot for the attachment of a booby trap would be one to explode when the hatch cover is lifted.

c. Operation.—When downward pressure is applied to the cover, it moves downwards against the compression of the springs. As the cover moves downwards, the cutter rides into the guide and shears the wire, thus freeing the striker. The striker, under pressure from

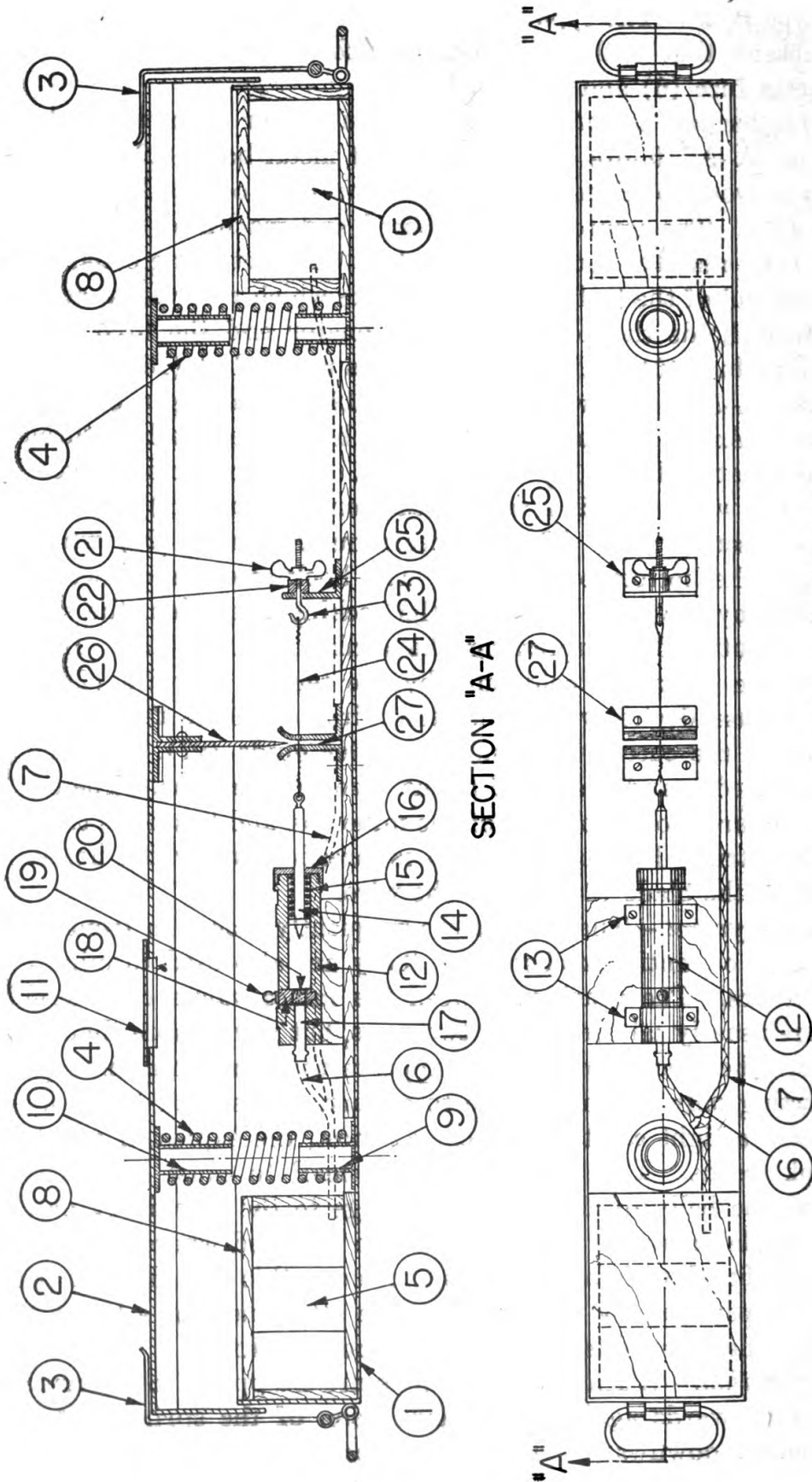

FIGURE 68.—Antitank mine, type B-2, S. C. G. (plan and section).

the compressed striker spring, is propelled against the percussion cap. The flame from the percussion cap ignites double-ended detonator and the cordtex fuzes, which in turn explodes the detonator and the mine charges.

d. To disarm.—Open the hinged lid (11), remove the cap holder from the igniter, and extract the percussion cap from the holder. Then place a coin or similar object in the cap holder recess (18) to prevent the striker point from striking the detonator if the striker should be accidentally released. Next, remove the cover by first releasing the L-shaped hooks, and extract the detonator. Finally, uncock the striker by backing off on the wing nut until the compression in the striker spring has been released, and replace the mine cover.

e. To arm.—To arm the mine, remove the cover by first releasing the L-shaped hooks. Then cock the striker by taking up on the wing nut until the striker spring is compressed. Insert a coin or similar object in the cap holder recess, and then insert the detonator. Now replace the cover and lock it in place with the L-shaped hooks. Finally, remove the coin or similar object from the recess and insert in its place the cap holder containing the percussion cap.

79. Type B-2 (hinged lid) (fig. 69).—This crude Italian improvised antitank mine is similar to antitank mine type B-2 (see par. 77) and type B-2, S. C. G. model (see par. 78).

a. Description.—The mine assembly is contained in a long narrow wooden box (1) with a wooden hinged lid (2). The box is divided into two compartments by a wooden partition (3); the small compartment is provided for the charge (not shown) of TNT, and the larger one for the firing assembly. Two blocks (4) in corners of the box support pressure springs (5). When the lid is closed, plugs (6) mounted to the underside of the lid fit into the springs and hold the springs in place. The firing assembly is supported by the E-shaped metal bracket (7). One arm of the bracket is fixed to the partition; the hole (8) in this arm of the bracket and the partition is provided for the insertion and support of a percussion detonator, the end of which protrudes into the TNT charge. The other two arms of the bracket support the striker pin (9) and striker spring (10). The striker spring is held compressed, and the striker pin cocked, by a retaining wire (11) fastened to the bolt (12) mounted in the end of the box. A cutting block (13) is mounted on the floor of the box beneath the wire. On the underside of the lid a cutting blade (14) is mounted. When the lid is closed, the blade is positioned over the block. A slot (15) in the lid is often provided to permit the insertion of a safety strip in the space (16) to interrupt the forward travel c

the striker pin, and hence to prevent the firing of the mine. When the mine is laid, the springs support the lid in a slightly open position, and resist further closure of the mine cover except under pressures adequate to actuate the firing mechanism and explode the mine. Screw eyes (17) are provided in the lid to assist in latching it in position to the box.

b. Employment.—These mines are generally employed in front of, or in the gaps of, antitank obstacles; they are also used to mine detours. The spacing of the mines varies considerably, but never more than three rows have yet been encountered. Usually they are laid in two rows, sometimes one row. This mine as illustrated and described herein is capable of inflicting only minor damage to a tank and, therefore, it should be considered a light antitank mine. Whether booby traps have been fitted to this variation of the B-2 mines is not known, but since

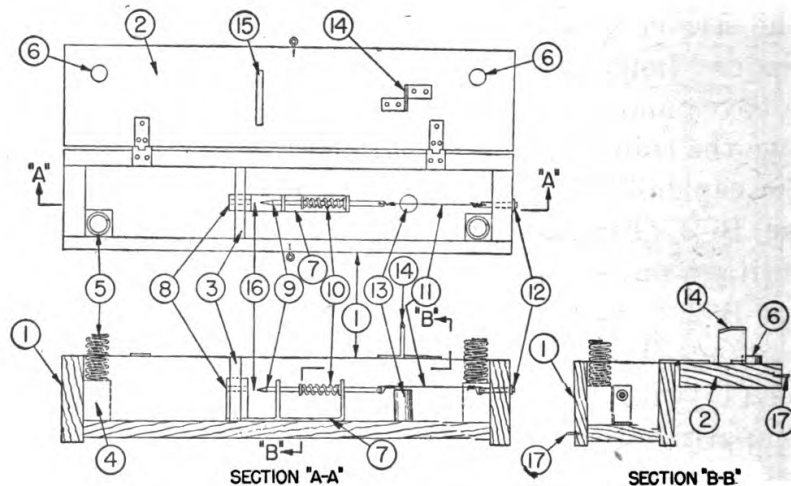

FIGURE 69.—Antitank mine, type B-2 (hinged lid).

it is feasible to do so they should be handled with caution. The obvious booby trap would be one that fired when the cover is lifted or when a strip is inserted in the slot (15).

c. Operation.—When a vehicle rides over the mine, the lid is pressed downward and the blade cuts the wire, thus releasing the striker pin, which fires the detonator, which in turn fires the mine.

d. To disarm.—The firing assembly is neutralized by inserting a metal or wooden strip through the slot (15) into the space (16) to interrupt the forward travel of the striker. Open the lid and remove the percussion cap and detonator. If there is no slot (15), open the lid first, then place a metal or wooden strip in the space. It is probable that the detonator can be extracted from the hole by simple pressure with the fingers; however, the charge must first be removed piece by piece and the primer block of TNT slipped off the detonator. **Caution:**

Do not force the lid when opening it; the lid should open easily. Because the mine may be set for firing when the cover is lifted, this mine should be fired in place if feasible.

e. To arm.—Fasten the tension wire (11) to the striker pin and the bolt (12). Place a strip of wood or metal in the space (16) to act as stop to interrupt the striker in case of accidental release. Insert the detonator in the hole (8) and in the primer charge of TNT. Place the charge in the mine. Close the lid on the springs. Remove the safety strip through the slot (15).

80. Type 9, pressure operated (figs. 70 and 71).—This Italian antitank mine is regarded as an improvised mine to be made up by the Italian engineers in the field. For this reason variations of the type described here are to be expected. The mine is generally made up of two separate and identical detonating mechanisms, each consisting of a detonator and cartridge unit and a striker assembly. Each detonating mechanism is identical with the detonating mechanism used in the antipersonnel mine, type 9, pressure operated, described in paragraph 91.

a. Description.—The mine (fig. 70) is enclosed in a wooden box (1) 6½ inches wide, 5 inches high, and 41 inches long. The box is provided with a loose-fitting wooden cover (2). The two identical detonating mechanisms are located at opposite ends of the mine. The explosive (3) in the box consists of eight blocks of TNT placed so as to be in contact with the detonators (6). Each of the detonating mechanisms (see fig. 71) consists of a small-arms cartridge (7) and detonator. The small-arms cartridge fits into a cylindrical body (4). The detonator projects into a recess in the explosive. The striker mechanism is enclosed in a tubular metal striker guide (5). The detonator is the standard nonelectric type (Italian No. 8 detonator), one end of which is fixed in the mouth of a small-arms cartridge from which the bullet has been removed. The support for the cylindrical body, which contains the small-arms cartridge, is not clearly described in the available literature on this mine. The striker guide is supported on a metal base plate (8) secured to a wood filler attached to the bottom of the box. Two bent metal plates (9) are fastened to the base plate and extend upward on each side of the end of the striker guide, forming a support for the trip lever (13), which pivots on the pin (10). To permit proper functioning of the striker mechanism, the striker guide is restrained, in some manner not made clear in available literature on this mine, from lateral and longitudinal movement. The striker guide is capable of being rotated to permit its being detached from the body and removed from the mine. The attachment of the striker guide

to the body is accomplished by means of an interlocking connection, the details of which are not clear from information available. An interpretation of the interlocking connection is shown in figure 71. The striker mechanism consists of a striker (11), a striker spring (12), and the trip lever as shown in figure 71. The striker is held in the cocked position against the compression of the striker spring by the lower arm of the trip lever, which engages the stop nut (14).

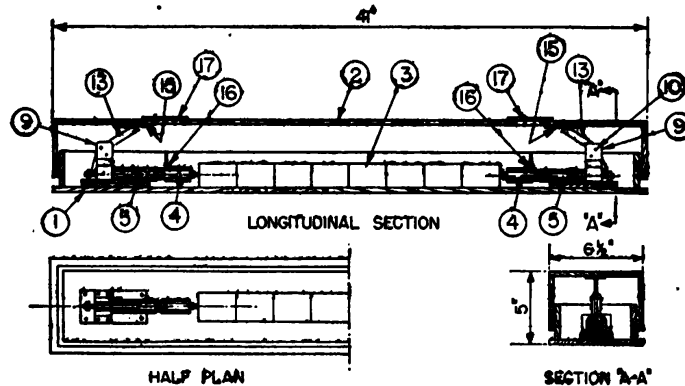

FIGURE 70.—Antitank mine, type 9, pressure-operated—plan and sections.

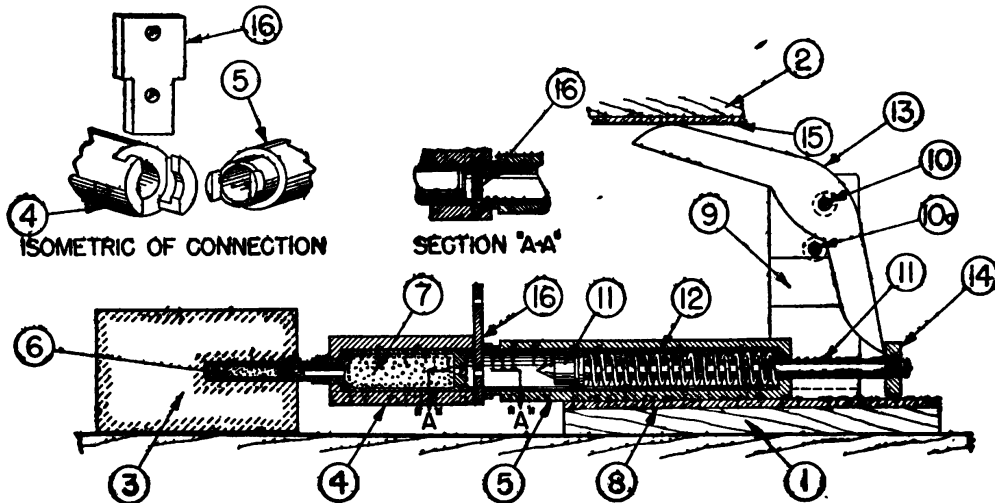

FIGURE 71.—Antitank mine, type 9, pressure-operated—details.

The trip lever, which pivots on pin, tends to turn clockwise when it is engaged with the stop nut by virtue of the compression of the spring, but is prevented from doing so by the pin (10a). The upper arm of the trip lever bears against a small metal plate (15) on the under side of the mine cover. A safety strip (16) fits loosely into a slot formed by the interlocking connection between the body and striker guide. When the safety strip is in the slot, the striker is prevented from striking the cartridge. The exact shape of the safety strip is not clear from information available, but an interpretation is shown in figure 71. A pivoted lid (17) is provided in the

cover of the mine over each striker mechanism and serves as an access to withdraw or insert the safety strip.

b. Employment.—These mines are generally used for antitank purposes and laid about 6 inches under the ground surface.

c. Operation.—In the armed condition, each detonator and cartridge is in place; each striker is cocked and held by its trip lever as shown in figure 71; and the safety strips have been removed from their slots. When pressure is applied on the top of the mine, the cover moves downward and rotates the trip levers about their pivots, causing the lower arm of each lever to disengage its stop nut, thus releasing the strikers. The strikers, under pressure from the compressed springs, are propelled against the cap end of the cartridges, causing the detonators to explode the mine.

d. To disarm.—First, neutralize the mine by inserting a knife blade or similarly shaped object in each of the slots designed to receive the safety strips, making certain that each is capable of intercepting the striker. Wood blocking should be placed between the cover and the exterior projecting parts of the bottom of the box so as to prevent downward movement of the cover when opening the lids (17). To disarm the mine completely, continue in the following order: Carefully remove the cover. The removal of the cover will cause the rotation of the levers (13) until they are in contact with the stops (10a). Next, release each striker guide in turn by rotating it slightly until it becomes disengaged from the body. When the striker guides are disengaged they should be removed from the mine. Each body and its contained cartridge and the detonator should be removed in turn.

e. To arm.—To arm the mine from the disarmed condition as described above, proceed as follows: Each striker guide and cylindrical body should be assembled with the detonator inserted in the charge and the cartridge in its proper place in the body, and each complete assembly placed in proper position in the mine. Each safety strip should then be placed in its slot, and each striker then cocked, and its nut engaged to the lower arm of its companion trip lever. The cover should then be placed on carefully so as to avoid transmitting any pressure to the levers in excess of the weight of the cover. Finally, each safety strip should be removed from the mine through the access holes covered by the lids (17).

81. Type N, improvised (fig. 72).—These Italian mines are apparently prepared in the field and bear no markings. Two of these mines were found by the British in Nairobi. A test on one of them showed that the mine detonated with fair violence when a box weighing 100 pounds was dropped onto it from a height of 5 feet. The

other mine was tested, using only one U. S. No. 27 detonator instead of two Italian detonators. This mine exploded with an effect similar to the first. The mines thus appear to be serviceable for reuse by our troops.

a. Description.—The following description covers only the mines which have been examined by our troops or those of our allies. The mine is enclosed in a wooden box (1) and has a sheet metal pressure cover (2) which is underlined or stiffened with wood. With the pressure cover in place, the mines which have been examined measured 5½ inches wide, 8 inches high, and 16 inches long. It may be expected that this type of mine will vary in size depending on the amount of explosive it is desired to use for the contemplated purpose. The pressure cover is generally painted dull red, but other colors may be used to harmonize with the surroundings. The upper surface of the bottom and the top of the box are covered with metal plates (4). The box is

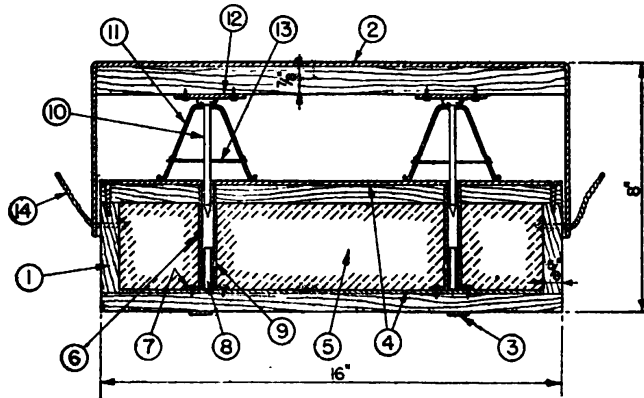

FIGURE 72.—Antitank mine, type N, improvised.

bound with metal strips (3) and contains 5 pounds of gelnite explosive (5). Two steel tubes (6) pass through the explosive. These tubes are fastened at their upper end by the top of the box, and at their lower end by washers (7), which are in turn held in place by screws which fasten into the base of the box. Detonators (8) fit into the lower end of each tube, each of which is provided with a flash hole (9). The upper parts of the tubes act as guides for the strikers (10), which are supported and held in a cocked position by springs (11). The strikers in this position support the cover at the pressure plates (12). The springs are made of straps of steel punched to receive the strikers and bent as shown to form an inverted "V" support. The springs are strengthened by binding them with two strands of piano wire (13) to prevent the detonator from being fired by too light a pressure. The pressure plates are screwed to the underside of the wood underlining of the metal pressure cover. Two rope handles (14) are provided for carrying the

b. Employment.—There is no information available on the specific uses of this mine. Since it is operated by pressure on the cover, the mine appears suitable for antitank, antivehicle, or railway demolition.

c. Operation.—In the armed condition, the detonators are in place and the strikers are supported by the springs as shown in figure 72. When pressure is applied to the pressure cover the springs are flattened and the strikers driven down so as to perforate the cap in the top of the detonator. The cap discharges the detonator, which in turn explodes the mine.

d. To disarm.—The cover of the mine, the strikers, and the V-springs should first be carefully removed. The detonators should be removed from the tubes by placing the mine box on its side and tipping it to gently slide the detonators out of the mine. Lay the springs and strikers on their sides on the top of the box and the cover may then be replaced.

e. To arm.—To arm the mine, proceed in the following order: Remove the cover and insert a detonator carefully in the lower end of each tube with cap end of each detonator up. Next, place each supporting spring in an upright position over tubes and insert the strikers as shown in figure 72 and replace the cover (2).

82. Type D (fig. 73).—This antitank mine is a departure from the characteristic box shape of most Italian mines and is somewhat similar to the German Tellermine. There is no information available on the weight of the mine or the quantity of explosive used, except that the charge is less than the 11-pound charge used in the Tellermine.

a. Description.—The external housing of the mine is made of pressed steel and is $3\frac{1}{2}$ inches high and 1 foot in diameter. The top housing (2) has a saucer-shaped depression in the center and is held down against the springs (5) by a metal band (4) attached to the base housing (1). The base housing is made so that the top housing can ride down inside the base housing when pressure is applied to the top of the mine. The springs retain the top housing in its normal upraised position and serve to regulate the pressure required to actuate the mine. The base housing contains the explosive (3), which is confined in a metal shell (30). The metal shell is formed to receive a cylindrical body (6) which supports the striker mechanism above it. A center cylindrical hole or tube (7) in the cylindrical body is designed to receive the detonator. It is presumed that the cylindrical body contains a booster charge and that the percussion cap is in the upper portion of the detonator contained in tube. A screw plug (8) in the base of the cylindrical body permits the insertion of the detonator in the center

tube. The striker mechanism consists of a head piece (9) with a sliding fit over the metal guide (10) which encloses the striker assembly. The metal guide is the support for the striker mechanism, and is fixed to the top of the cylindrical body by tap screws (11). The striker assembly consists of a sliding body (12), the firing pin or striker (13), and the spring (14). The striker is held in a cocked position within the body (12) by the compressed spring (14) and the steel balls (15). A screw plug (16) screws into the top housing of the mine and serves as an access to the igniter. The safety device for the mine consists of a channel (17) which can move radially in and out of an opening in the lower portion of the metal guide. The channel is operated by a toggle assembly which is controlled from the top and outside of the mine. When the mine is in a safe condition, the channel is positioned between the point of the striker and the detonator. The channel is held in position and its movement is controlled by the pin (18) which fits into the slotted hole of the channel. The two projections (19) on the body (6) act as a guide for the channel. The toggle assembly is mounted on the pin (20), which turns in the collar (21) fixed to the upper housing of the mine. One (lower) arm (22) of the toggle engages the recessed fittings (23) attached to the channel. The other (upper) arm (24) of the toggle is limited in its movement by the stops (25) and (25a). The collar contains a spring to provide resistance against accidental movement of the toggle. When the mine is in the safe condition, the toggle is positioned as shown in solid outline in figure 73 (Plan of safety device), and is held by the split pin (26) and ring (26a) to the stop (25). When the mine is armed, the upper toggle arm is against the stop (25a) in the position as shown by the broken lines in figure 73 (Plan of safety device). The movement of the upper toggle arm to arm the mine rotates the lower arm and pulls the channel outward and free of the metal guide. At the same time, by means not shown in the figures, a stop (27), interconnected with the safety device, is moved out of engagement with a tumbler (28). A tumbler spring (29) rotates the tumbler on its pivot and the tumbler locks the stop (27) and the channel from being returned to the "safe" position.

b. Employment.—This mine is used for antitank purposes. Further information on its use is not available.

c. Operation.—When pressure is applied to the top of the mine, the top housing of the mine moves down, against the pressure of the springs, breaking the seal with the lower housing at the edge. The screw plug in the top cover depresses the igniter head piece, which

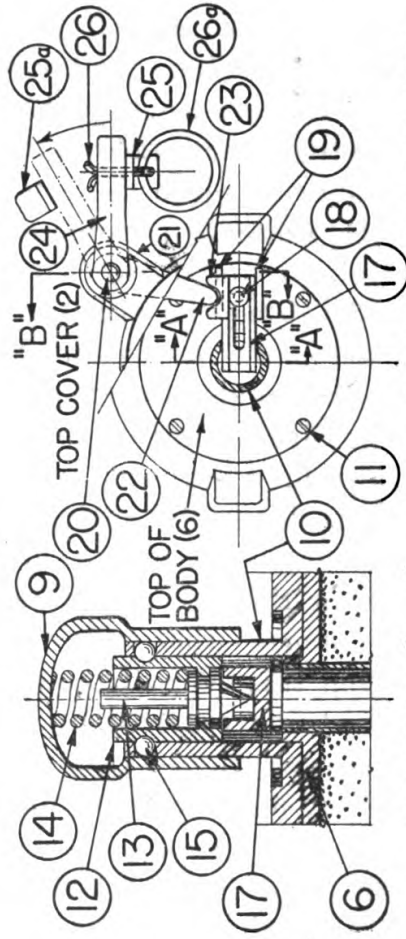
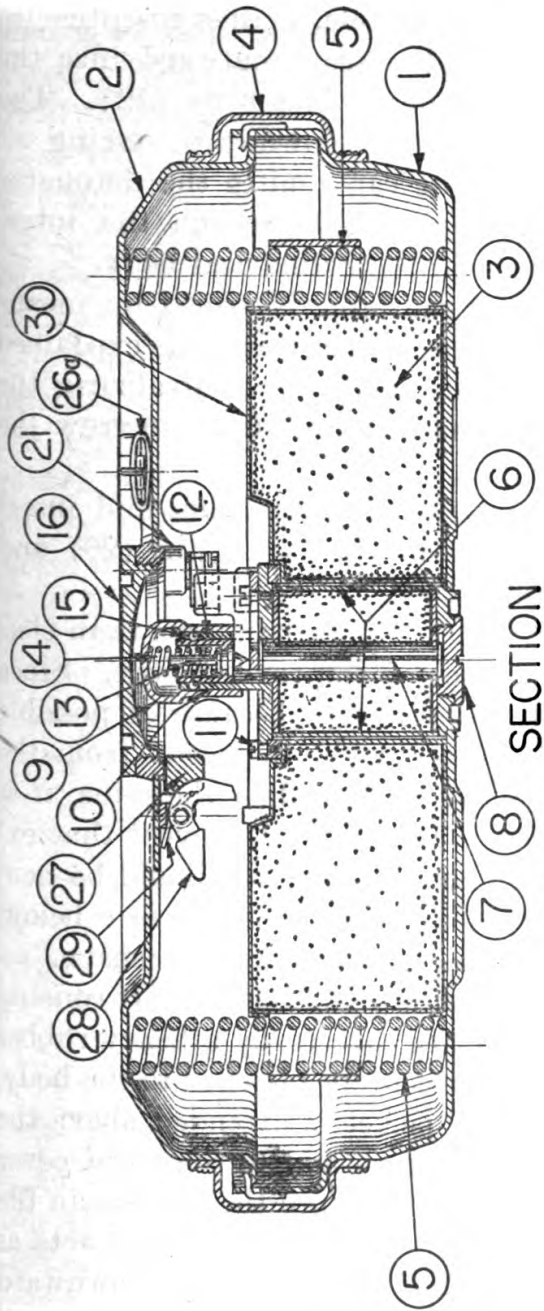

SECTION "A-A" PLAN OF SAFETY DEVICE

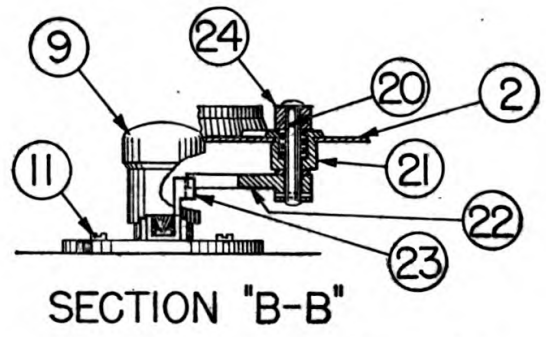

SECTION "B-B"

FIGURE 73.—Antitank mine, type D.

moves downward with respect to the metal guide, against the pressure of the striker spring, until the steel balls escape outward into the space within the head piece, thus releasing striker body (12). The compressed striker spring propels the striker downward, setting off the percussion cap. The flame from the cap ignites the detonator which in turn sets off the explosive, probably through the intermediate explosion of a booster charge in the cylindrical body.

d. To disarm.—Once the igniter of the mine is armed by means of the toggle arm (24), the igniter cannot be neutralized as explained in *a* above. Since there is no provision made for neutralizing the igniter, the only possible step to disarm the mine is to unscrew the base plug (8) and remove the detonator.

e. To arm.—To arm the mine, unscrew the base plug and insert the detonator with cap. Secondly, remove the split pin (26) and push the toggle arm (24) to the stop (25a).

83. Electric mine, type 2 (fig. 74).—This Italian mine is an electrically fired antitank mine, probably of an improvised type. Since there is danger of setting off mines of this type because of possible accidental short circuit in the voltmeter or in the leads from the mine, or through accidental depression of the lid of the mine, *it is recommended that they be exploded in place.* In the event that exploding this type of mine in place is not feasible, it should be neutralized and removed by *trained* personnel as described in *c* below.

a. Description.—This antitank mine is cylindrical in shape, resembling a small flat drum with wooden top and bottom. It consists of a cylindrical metal body (1) generally covered by a heavy rubber jacket (2), a wooden base (3) which is securely fastened to the body, and a wooden cover (4). The rubber jacket is extended above the metal cylinder and is fixed to the wood base and to the wood cover by steel rings (5) which compress the rubber into the grooves in the wood to make the mine moisture-proof. The rubber jacket acts as a support for the cover and permits the cover to move downward under pressure. Attached at the top of the metal cylinder are small pieces of metal angles (6). These angles come in contact with a steel plate (7) on the underside of the cover when the cover is depressed. The mine contains an explosive TNT (8) fitted into the base, an electrical detonator (9) inserted in the top of the explosive, and a 4½-volt battery (10) which supplies the current required to explode the electric detonator. The metal cylinder is connected to one terminal of the battery by the wire (11). The metal plate fixed to the underside of the wooden cover is connected by wire (12) to one lead of the electric detonator. The other lead of the detonator is connected to the battery by means of the wires (16) and (13) which come into

contact at the receptacle (14) when the bridging plug (15) is inserted. When plate (7) comes in contact with angles (6) the electrical circuit is closed and the mine is exploded. Outside of the mine, the wires (13) and (16) are probably enclosed in a common exterior covering, and together with the bridging plug provide a test lead. The bridging plug constitutes the safety device, because when it is removed the electrical circuit is broken. A voltmeter (17) with wire leads and plug (18) is used to test the circuit.

b. Employment.—There is no specific information available on detailed use of this mine other than that it is an antitank type.

c. Operation.—Pressure on the top of the mine will compress the rubber jacket and move the cover downward until the metal plate on the underside of the cover contacts the angles. This contact closes the circuit and the mine is exploded. It is essential that plug (15) be inserted in socket (14) in order for the mine to function.

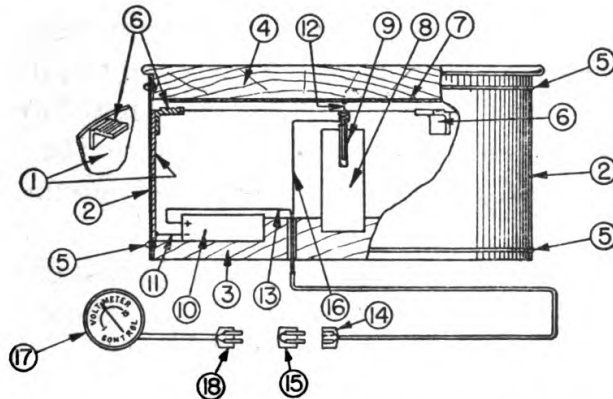

FIGURE 74.—Antitank electric mine, type 2.

d. To disarm.—If exploding the mine in place is not feasible, the mine should be disarmed as follows: Examine the outside of the mine for the test wires, which will be found to enter the mine through either the top or bottom. Although it appears that the bridging plug should now be removed to break the circuit, for some reason the instructions covering the use of this mine make no mention of this method of breaking the circuit, but, instead, give instructions to cut each wire (13) and (16) of the test lead separately, and coil them apart. If the two wires are fastened together or have a common exterior covering, the wires should be separated before cutting. It is important to keep these instructions in mind, since simultaneous cutting of both wires may produce an electrical contact between the two wires, shorting the circuit and, under certain circumstances, exploding the mine. The shorting of the circuit ordinarily would have no effect unless the circuit is closed by the cover plate being in contact with the angles. However, if the wiring in the mine is

changed from that shown, the mine may explode merely by shorting the test lead. The top steel ring (5) should then be cut and the cover (4) carefully raised until the coiled wire (12) joining the cover and the detonator can be reached and cut. The cover should then be removed. Finally, the wire (16) attached to the detonator should be cut, and the detonator removed.

e. To arm.—There is no information available on rearming this mine, probably because its reuse is not recommended. However, if the mine has been disarmed as described in *d* above, reverse procedures can be followed; such rearming should be undertaken only by experienced personnel. In the event the mine is properly armed, a voltmeter test may be made as follows, for the purpose of testing the battery voltage and the circuit: Remove the bridging plug, connect the voltmeter to the receptacle (14) by means of plug (18), and depress cover (4) until it contacts the angles (6). If the circuit is complete, full battery voltage will register on the voltmeter, whereas the current (as expressed in amperes) flowing through the circuit will be less than is required to explode the detonator because of the high resistance of the voltmeter. Therefore, the voltmeter used must have sufficient resistance to reduce the current to that amount which is safe to pass through the detonator without exploding it.

84. Improvised mine employing HE (high explosive) shells (figs. 75 and 76).—This Italian mine falls in the category of mines which are improvised from the munitions of war containing high explosives, such as shells, aerial bombs, and grenades. This particular mine utilizes a high explosive shell.

a. Description.—The mine is enclosed in a wooden box (1) 8½ inches wide by 6½ inches high by 11½ inches long. It has a sheet metal pressure cover (2) slightly gabled as shown in figure 75. The metal cover is supported by the trip lever (7) and is held in position by wires (not shown) passing over the pressure cover and fastening to pegs (not shown) on the side of the box. The box has a false bottom (3) which is held in place by screws through the side walls of the box. The striker mechanism is mounted on the false bottom and consists of a striker guide tube (4), striker (5), a striker spring (6), and an L-shaped trip lever (7). The explosive is contained in the bottom of the box and consists of two HE (high explosive) shells (8) and four sticks of gelignite (9). A detonator (10) with a percussion cap (20) in its top fits into a tube (11) positioned below the striker tube (4). The trip lever (7) pivots on pin (12) at the upper end of tube (4). The vertical arm of the trip lever has a catch (13) which projects through a hole in the tube and fits under the flanged head of the

striker. In this position, the striker is prevented from moving downward. The horizontal arm of the trip lever has a notch (21) at the end which fits over the cam (14) when the cam is turned so that its longer axis is vertical. The cam constitutes a safety lock and pivots on the screw (15), and, when in the vertical or "safe" position, pre-

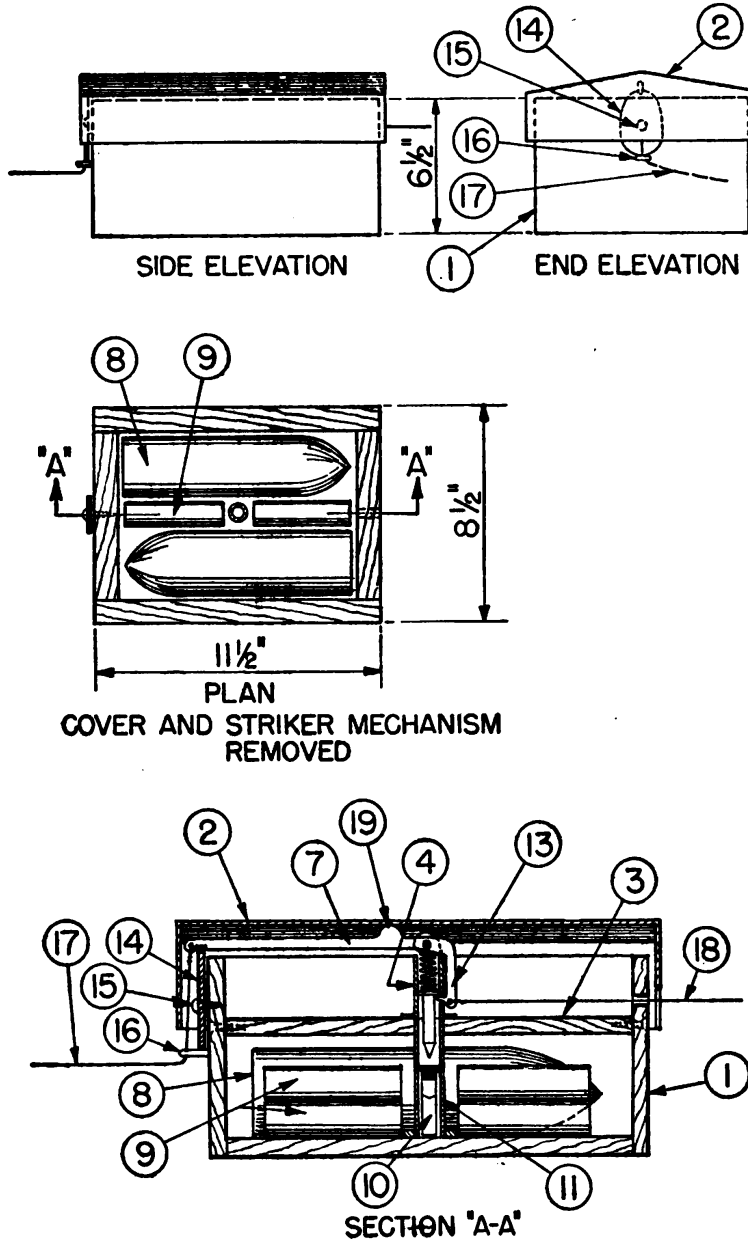

FIGURE 75.—Improved mine, HE shells.

vents the long arm of the lever from rotating downward, and the short arm outward, thus disengaging the catch from the striker. In the safe position, the cam is probably somewhat restrained from free movement by the frictional contact of its lower end with the screw eye (16). A trip wire (17) passes through the screw eye and is at-

tached to the cam (notched) end of lever (7). Another trip wire (18) passes through the opposite end of the box and is secured to the trip lever at the catch (13). Both of these wires (17) and (18) function as pull wires to rotate the lever (7). The cover of the mine functions as a pressure head and transmits pressure to rotate the lever (7) through bearing on the lug (19) on the trip lever.

b. Employment.—Although information is lacking on how the enemy uses these mines, it appears that they might be used in booby traps or in minefields.

c. Operations.—The mine is armed by rotating the cam out of engagement with the notch (21). Until this is done, neither pressure transmitted to the lug (19) nor pull applied to the trip wires (18) or (19) will operate the lever (7). When the mine is armed any one of

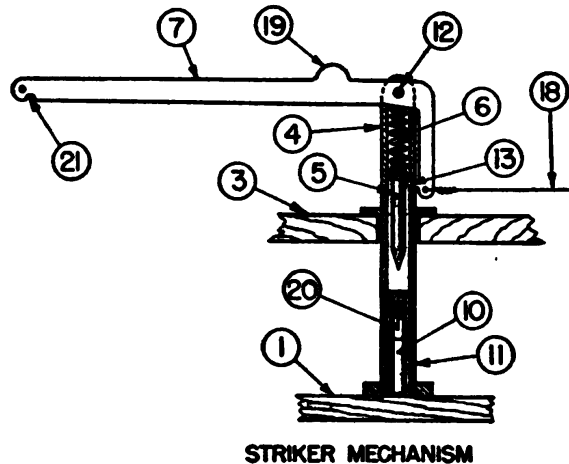

FIGURE 76.—Improvised mine, HE shells—detail.

the above three actions will rotate the lever, and release the catch from under the head of the striker. The striker, under pressure of the spring above, is propelled downward, firing the percussion cap and the detonator, which in turn detonates the explosive charges (8) and (9).

d. To disarm.—First, neutralize the igniter by gently rotating the cam until its longer axis is vertical and is engaged with the notch in the long arm of the trip lever. This action locks the trip lever against rotation. Then cut the trip wires (17) and (18) and the wires holding the pressure cover in place. Remove the cover carefully and bind the vertical arm of lever, just above catch, to tube (4) so that the catch cannot release the striker. Remove the screws holding the false bottom and remove the false bottom together with the striker assembly. Withdraw the tube (11) holding the detonator by pulling the tube and at the same time turning it slightly so that it becomes disengaged.

e. To arm.—Although no published information is available on arming this mine, it appears that it may be armed safely by proceeding in the following manner: Replace the detonator tube (11), together with the detonator and the false bottom. Stretch out the wires (17) and (18), which are 10 to 16 feet long, and attach the far ends to posts, bushes, or other objects. Mount the striker assembly on the false bottom, making sure that the striker assembly is bound so that the catch (13) is engaged and cannot be released without removing the binding. Rotate the cam until it engages the notch of the trip lever and secure wires (17) and (18) to the lever. Wires (17) and (18) should not be in tension, as they would rotate the lever and release the firing mechanism. Carefully unwrap the binding around the vertical arm of the trip lever and striker tube. Finally, place the cover over the mine and disengage the cam from the trip lever.

85. Land mine, metal tube (fig. 77).—*a. Description.*—The body of this Italian mine consists mainly of a metal tube (1) which is approximately 2½ inches in diameter and 27 inches long. The tube has a wall thickness slightly less than ¼ inch and looks like a piece of ordinary pipe. At one end of the tube is an iron band or collar (2) which is approximately 2½ inches wide and 4½ inches in diameter. It is secured to the tube by wood packing (12). Contained within the tube is the igniter and five pounds of explosive (3), which is confined between the wood plugs (4) and (5). The igniter consists of a detonator (6) fitted into a hole in the plug (5), a striker (7), a striker guide plate (8), a striker release (9) which is fitted in the collar, a striker spring (10), a wooden plug (11), and a safety pin (14) inserted in hole (15) in the striker. The striker guide plate is fixed to the striker, so as to move with it and guide it in the tube. It is assumed that the striker release has a projection or lip (16) to restrain the striker. The external part of the striker release mounts a pressure bar (17) ¾ inch wide by 5 inches long. The exact appearance of the striker release and the pressure bar are not known, but section B-B of figure 77 is drawn to show how they probably appear when the striker release is in the locked position. A wooden peg (13) holds the wooden cap plug in place.

b. Employment.—No information is available at this time as to the employment of this mine; however, it appears adaptable to antitank or antivehicular use.

c. Operation.—Pressure on the pressure bar of the striker release (9) moves the striker release downwards so that the lip will clear the striker guide plate. Clearing of the striker guide plate releases

the striker, which, under pressure from the spring, is propelled forward, striking a cap in detonator, thus causing the detonator to explode and to set off the charge beyond.

d. To disarm.—Neutralize the igniter by inserting a safety pin or wire in the hole (15) in the striker. Then bind two pieces of wood $\frac{1}{2}$ inch long under the external pressure bar. Remove the wooden peg and withdraw the cap plug, complete with striker assembly. The detonator is then removed by gently tapping the tube, causing the detonator to be jarred loose. Remove the detonator. Uncock the striker by removing the safety pin and then replace the cap plug.

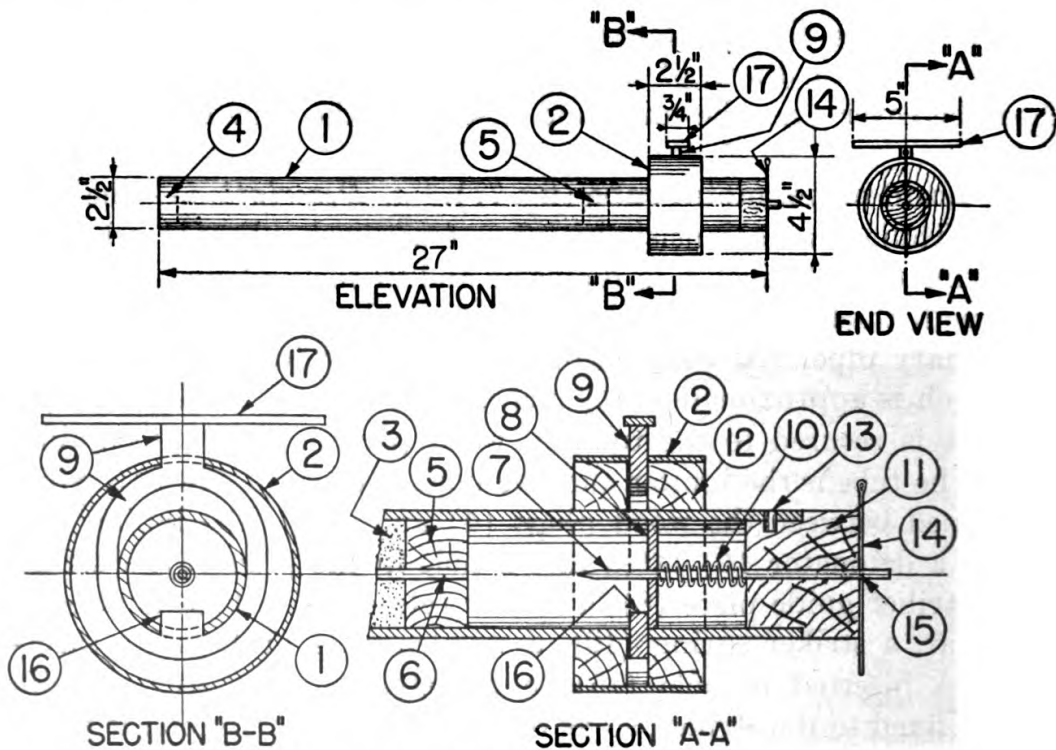

FIGURE 77.—Land mine, metal tube type.

e. To arm.—To arm the mine remove the plug. Assemble the striker parts by placing the striker spring in position on the striker between the guide plate of striker and the cap plug, inserting the safety pin to hold the parts together. Insert detonator in the hole in the plug (5) so that it projects into the explosive and place the striker release in a locking position by binding two pieces of wood $\frac{1}{2}$ inch long under the external pressure bar. Replace the cocked striker assembly and secure it with the wooden peg (13). To complete the arming remove the $\frac{1}{2}$ -inch-long wood pieces under pressure bar and then pull out the safety pin.

86. Pressure mine with grenade exploder (fig. 78).—*a. Description.*—The Italian pressure mine with grenade exploder, as shown

in figure 78, is believed to be a correct interpretation of the original Italian literature pertaining to this mine, which is somewhat indefinite. This Italian pressure mine consists chiefly of a cylindrical canister (1) 6 inches in diameter by 10 inches in height, containing 12 pounds of explosive (2) and an igniter assembly. This assembly may be that used in an ordinary hand grenade. The igniter assembly is supported by the cover (3) of the canister and is held in place by a collar threaded onto the igniter body (4). The igniter assembly con-

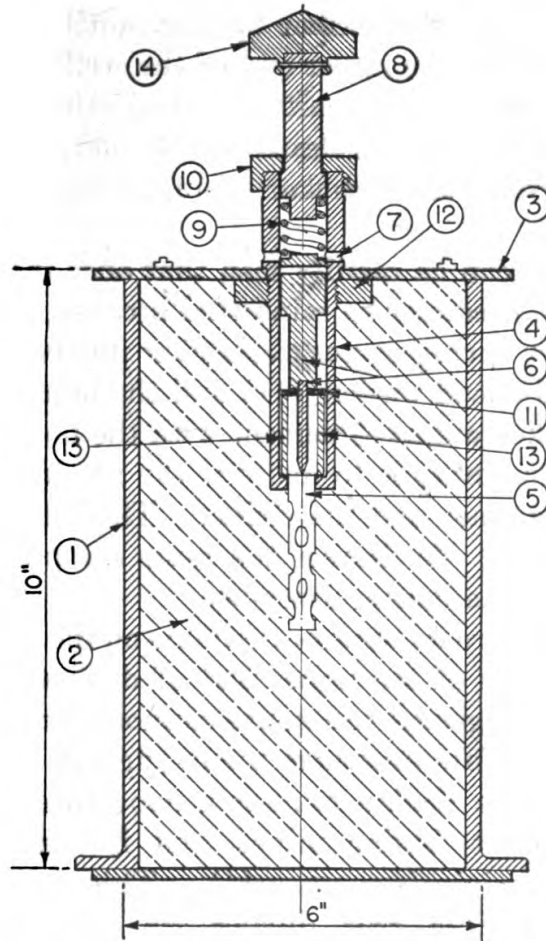

FIGURE 78.—Pressure mine with grenade exploder.

sists of the hollow metal cylindrical body (4) and the following other parts: the detonator (5), the striker (6), the striker hammer (8), the striker spring (9), the retaining collar (10), and the lead shear washer (11). It is believed that the detonator, which is supported by the lower end of the body, either has a percussion cap fitted in its upper end or that the detonator is sensitive enough to not require a cap. The striker has a sliding fit in the cylindrical body, and has a safety pin hole through its upper end. The striker hammer, which is fitted with a pressure head (14) at its upper end, rests against the striker compress-

sion spring (9) and is maintained in position by the retaining collar. The lead shear washer appears to bear on a tubular spacer (13).

b. Employment.—There is no information available at this time on the employment of this mine.

c. Operation.—When the safety pin (not shown) is withdrawn from the safety pin hole (7) the striker moves down until the shoulder of the striker bears on the lead shear washer as is shown in figure 78. In this position, the striker is supported on the lead washer and the mine is armed. Pressure applied on the striker hammer moves the hammer downward, compressing the striker spring, until the bottom of the striker hammer contacts the upper end of the striker. After this contact is made, the pressure is transmitted through the striker, and shears the lead washer. This action releases the striker, which is propelled downward by the compressed striker spring, firing the detonator and exploding the mine.

d. To disarm.—It can be readily seen that once the safety pin (not shown) is removed, it cannot be reinserted because, directly the pin is removed, the striker spring moves the striker pin (6) downwards into engagement with the lead washer (11) and the hole in the striker pin is automatically taken out of alinement with the hole (7) in the body. The only course remaining is to unscrew the retaining collar and remove the striker hammer and the striker. This places the mine in a neutralized condition. To disarm the mine completely, remove the cover and withdraw the igniter assembly.

e. To arm.—There are no reports available on the arming procedure. Since the exact details of the upper end of detonator have not been ascertained, a safe suggested procedure cannot be outlined.

87. Circular variable pressure mine (figs. 79 and 80).—The circular variable pressure Italian mine is a departure from the characteristic shape of most Italian mines, and is somewhat similar to the German Tellermine (see par. 44). This mine was first encountered in the Middle East during the enemy's attack on the Alamein defenses in the first week of September, 1942. As the name indicates, it is generally used to operate at varying pressures which range from 77 to 777 pounds. However, it may be set to operate by pull on a trip wire.

a. Description.—The assembled mine shown in figure 79 consists essentially of a flat circular steel container (1), a slightly dome-shaped steel cover (2), and a brass igniter (3) which screws into the top of the container and supports the cover. The mine is painted black. When fully assembled, it measures 3 inches in height and 10 inches in diameter at the cover, and weighs 8 pounds. The con-

tainer, the cover, and the igniter are described in detail in the following paragraphs:

(1) *Container and cover.*—The container is 8 inches in diameter and $1\frac{1}{4}$ inches high. It contains $3\frac{1}{2}$ pounds of explosive filling (4) which is similar in appearance to impure TNT and is wrapped in waxed black paper. Equidistant around the container are welded three angle lugs (5) which have a hole in the outstanding leg. The cover is supported on the igniter and held in place by three studs (6) which pass through the holes of the lugs and are secured by split pins passing through the lower hole (7). The cover has two slots (8) diametrically opposite each other which are used for the purpose of packing the mine.

(2) *Igniter.*—The igniter (fig. 80) consists of a body (9) which houses a striker (10) with a striker spring (11) and a plunger (12) held in place against the compression of the spring by the collar (13). The base of the striker has a depressed center portion (14) and a triangular flange (15) which bears against a hardened steel shear blade (16) passing through the body. Since the striker flange takes the form of a truncated cone, the pressure required to operate the igniter may be varied by varying the depth of the shear blade cut. This is done by fixing the position of the shear blade relative to the base of the striker flange. This is accomplished by an eccentric segment (17) on the underside of setting ring (18) mounted on the body. The segment projects into a slot (19) in the blade (16) and when the ring (18) is rotated the blade is moved inwards or outwards relative to the flange. A red setting mark (20) on the outer face of the ring indicates the setting of the igniter on the scale on the body. This scale has the following significance:

K represents a firing pressure of 35 kg or 77 pounds (lowest setting).

1 represents a firing pressure of 100 kg or 220 pounds.

2 represents a firing pressure of 200 kg or 440 pounds.

3 represents a firing pressure of 300 kg or 660 pounds.

N represents a firing pressure of 350 kg or 770 pounds (highest setting).

The rotation of the ring is limited in one direction by a stop and in the other direction by the stud (21). The igniter has a cylindrical safety pin (22) with a shoulder (23) which engages the depression of the striker and automatically locks itself in place if the striker is accidentally released. The safety pin has a 3-foot-long cord attached to its outer end and is prevented from falling out, or being accidentally withdrawn, by a piece of twine (31) passing

through a hole (32) in the pin and secured in a groove around the body. A tool is supplied with the igniter to facilitate the screwing of the collar by inserting its prongs into the depressions (24) of the collar. Screwed to the bottom of the body is a detonator housing (25) which contains a percussion cap (26) and a detonator (27)

b. Employment.—The mine is used as an antitank or antipersonnel mine. Mines so far encountered have been laid with the cover flush with the ground. Italian documents, however, state that the mine should be covered to a depth of from 2 to 4 inches.

c. Operation.—(1) *By pressure.*—The mine should be set for the desired pressure by turning the ring (18) so that the red mark is

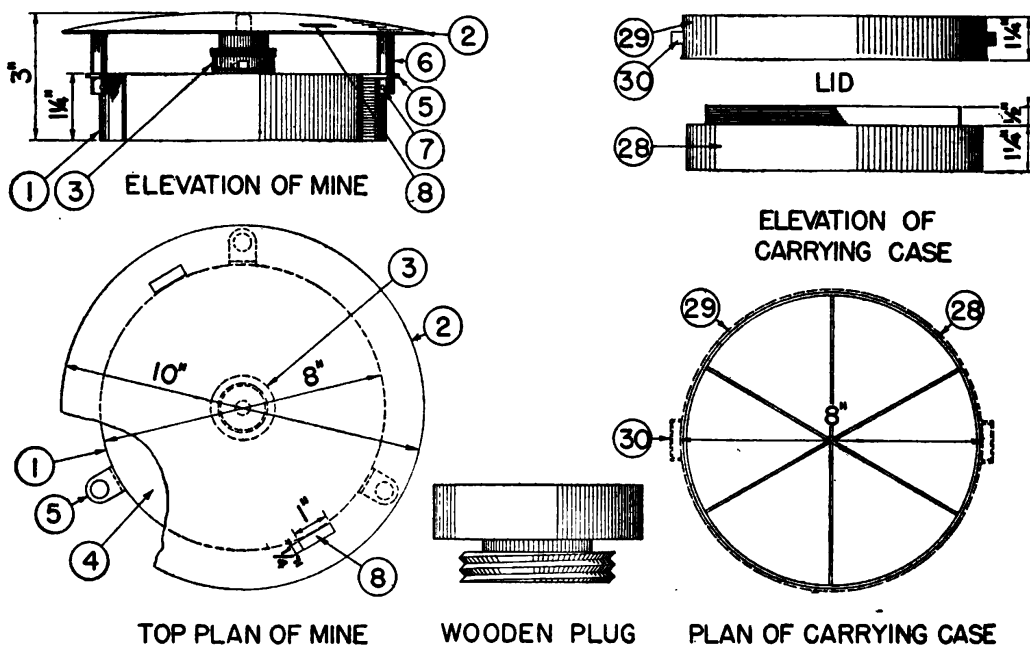

FIGURE 79.—Circular variable pressure mine and igniter carrying case.

opposite the scale figure, on the body, representing the desired pressure. When the pressure for which the igniter was set or a greater pressure is exerted on the cover, the plunger moves downward until its shoulder comes in contact with the top of the striker. The pressure forces the striker down until the shear blade cuts through the striker flange, thus releasing the striker. The striker under pressure from the spring is driven against the percussion cap, which fires the detonator, which in turn explodes the mine.

(2) *By trip wire.*—The mine should be set by removing the stud (21) so that the collar (18) can be turned until the red mark coincides with the mark "H" on the igniter scale. The rotation of the collar causes the segment (17) to withdraw from or move free of the slot (19). This releases the shear blade, which then can be withdrawn

by a pull on a trip wire attached to it. When a pull is exerted on the trip wire, the shear blade is withdrawn and the striker is released. The striker, under pressure from the spring, is driven against the percussion cap, which fires the detonator which, in turn, explodes the mine.

d. Method of packing (fig. 79).—As issued by the manufacturers, the igniter is replaced by a wooden plug having a threaded aluminum fitting which screws into the container. The cover is then fitted on top so that it rests on the wooden plug and is held in place by split

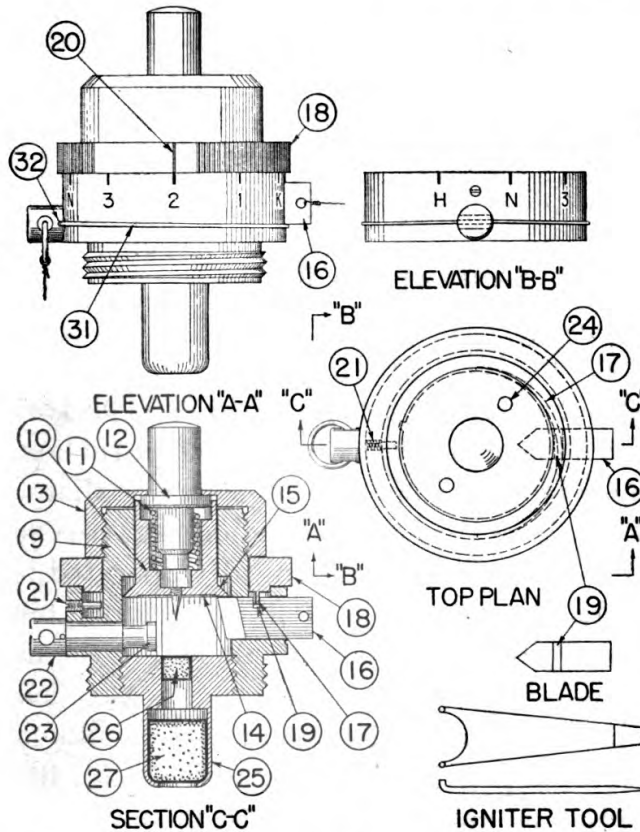

FIGURE 80.—Igniter in circular variable pressure mine—details.

pins or wires passed through the upper holes in the studs (6) of the cover. The igniters are carried separately in a steel container (28) which is partitioned radially to carry six igniters and has a lid (29). Each container also holds three igniter tools. In view of the fact that the slits (8) in the cover of the mine and the slots (30) on the side of the carrying case lid correspond exactly, it is thought that six mines and one igniter carrying case are packed one on top of the other with a strap or steel band passing through the slits and slots, clamping all seven together.

e. To disarm.—Look for any trip wires and if any exist, cut them without exerting any pull on the shear blade. Remove the split

pins from the cover studs, being careful not to exert any pressure on the cover, and carefully remove the cover. Then insert a pin (22), of as near the pin hole diameter as is available, in the safety pin hole to a depth of not less than $\frac{5}{8}$ inch. If the igniter has been set as a pull igniter, press home the shear blade. Finally, unscrew and remove the igniter from the mine.

f. To arm.—Remove the cover. Set the igniter to the desired firing pressure, or set it as a pull igniter. Then screw the igniter into the top of the container and lay out the safety pin withdrawal cord. If the igniter is to be pull operated, attach the trip wire to the hole in the shear blade. Now replace the cover and re-insert the split pins through the bottom holes in the studs. After the mine is covered, withdraw the safety pin.

SECTION III

RAILWAY MINE

Paragraph

Land mine, railway type..... 88

88. Land mine, railway type (fig. 81).—The Italian land mine, railway type, is a departure from the characteristic box shape of most Italian mines, and is somewhat similar to the Italian antitank mine, type D (see par. 82), and the German Tellermine (see par. 44). However, this mine does not have a mechanically operated igniter common to the Italian, type D, and the German Tellermine, but merely has a pointed rod (striker) to fire the percussion cap in the detonator. The name indicates that its general purpose must be to demolish railroad trains, but it is probable that it has other uses, as indicated by the low operating pressure, which is approximately 30 to 40 pounds.

a. Description.—The mine is cylindrical in shape, is about 12 inches in diameter and 4 inches high, and consists of two light alloy castings, that is, a base (1) which holds the explosive and the detonator (4) and a top (2) which fits over the base and contains the striker rod (3). The detonator is held in a vertical position by the brass plug (5) which is screwed into the center of the base. The explosive charge, consisting of eight or nine sticks of gelignite or similar explosive, is placed loosely in the base; a half stick of explosive is fixed around the detonator to act as a booster charge. Four equally spaced stud bolts (6) are screwed into the base and project upward about 2 inches to retain the compression springs (7) and to provide a means of fastening the top to the base. The top has four holes located to accommodate the stud bolts, is supported on the springs (7), and is held in place by the wagon nuts (8). The striker (3) is located in the center of the

cover and consists of a pointed steel rod screwed through the top so as to project inside the cover about $\frac{3}{8}$ inch. The striker rod has a ring (10) at its outer end. A tapped hole (9) is provided in the side of the base as a safe position for the combination striker rod and ring, which then serves as a handle for carrying the mine. The mine does not have a locking safety device, as is general for other mines of similar type, but by removing the striker from the top, the firing device is inoperative (neutralized).

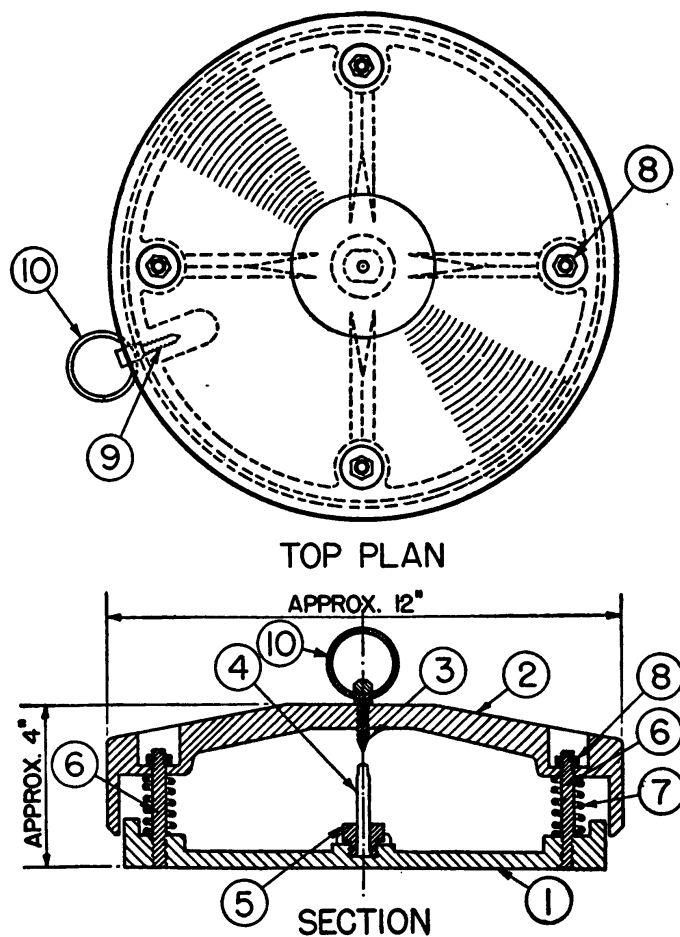

FIGURE 81.—Land mine, railway type.

b. Employment.—There is no information available on the specific uses or methods of using this mine, except as implied by the name given to the mine by the Italians, and the operating pressure which leads to the deductions given above. Although no antilifting devices or other secondary firing devices are known to be used with this mine, it must be remembered that it is always possible for the enemy to improvise methods or to use supplemental charges to explode the mine.

c. Operation.—Pressure on the top will force the top downward against the pressure of the compression springs, until the point of the striker is forced into the percussion cap located in the top of the

detonator. The cap will explode the detonator, which in turn will explode the booster charge, causing complete detonation of the main explosive.

d. To disarm.—Unscrew the striker rod (3) by means of the ring attached to it, and screw it into the carrying position in the tapped hole in the side of the base. The mine is now safe to move, but should be treated with caution until the detonator is removed. Proceed to remove the detonator by disassembling the mine in the following order: Unscrew the four nuts (8) and remove the top; remove the half stick of gelignite (booster charge) from the detonator; unscrew the brass plug and remove it and the detonator from the base. Detach the detonator from the plug. The mine can then be reassembled by screwing the plug into the base, replacing the top, and fastening it by means of the nuts (8). The mine is now safe to carry. The mine can be safely used for the storage of the booster and main charge, if desired, if the detonator has been removed. Ordinarily, however, this practice should be avoided.

e. To arm.—The arming operation for a mine which has been completely disarmed is the reverse of the disarming procedure as described above. The arming operation is as follows: Remove the top; screw the plug containing the detonator into the base; place a half stick of gelignite around the detonator; replace the top by fastening the nuts (8) in position; then screw the striker rod into the firing position in the top. The tops of the stud bolts are threaded for $\frac{1}{2}$ inch. This is probably for the purpose of adjusting the position of the top with respect to the base so that a definite clearance can be maintained between the striker and the cap located in the upper end of detonator.

SECTION IV

ANTIPERSONNEL MINES

	Paragraph
Type B-4.....	89
Type 9, improvised, tension-operated.....	90
Type 9, pressure-operated.....	91
Mine improvised from 2-kg. aerial bomb.....	92
Electric mine, type 2.....	93

89. Type B-4 (figs. 82 and 83).—This mine is the standard Italian antipersonnel mine. The Italians have used this mine quite extensively in Libya and Italian East Africa. Since the mine is actuated by both trip and tension wires, it is chiefly used against moving targets. The mine is said to have a shrapnel effect with considerable results within a range of 30 to 35 feet. It is easy to carry and manipulate and is quickly placed in position.

a. Description.—The mine has the appearance of a sheet metal canister. It is $2\frac{3}{4}$ inches in diameter, $5\frac{1}{8}$ inches high, and weighs $2\frac{1}{4}$ pounds when charged. The mine proper consists of two concentric sheet metal containers (1) and (2), and a superimposed top section (3). The containers are cylindrical except for a small flattened portion of the outer container (1) to facilitate setting the mine in position on a post or tree. The inner container (2) is $1\frac{3}{4}$ inches in diameter and contains a hollow bronze or steel casting (4). The intervening space between the casting and the container (2) is filled with the main explosive (5). The explosive consists of $\frac{1}{4}$ pound

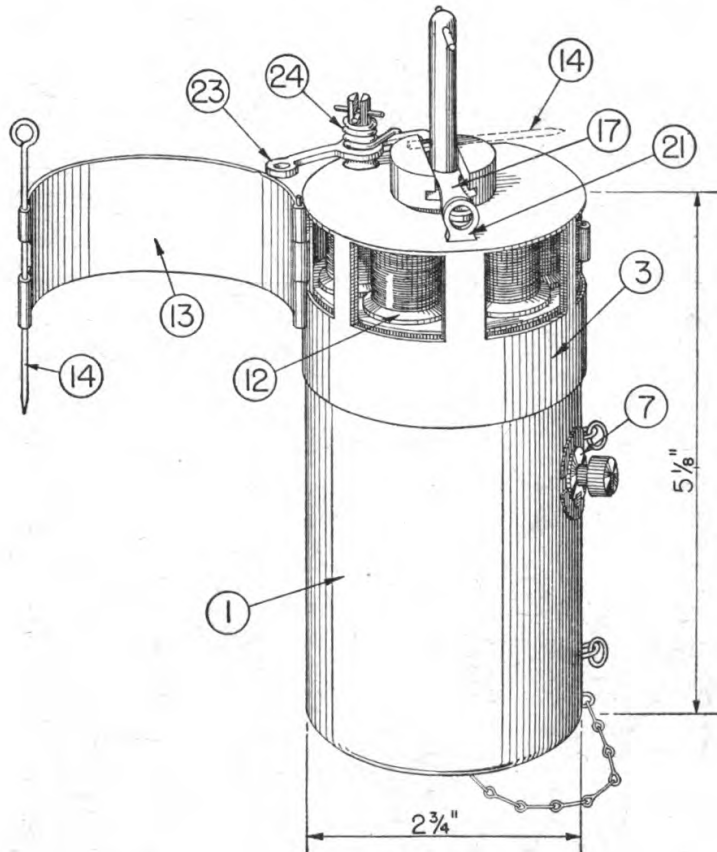

FIGURE 82.—Antipersonnel mine, type B-4.

of powdered TNT, which is introduced through filling holes (not shown) in the flattened side of the container (1) and the circular wall of the container (2). The space between the inner container and outer container is filled with scrap metal (6). The casting is bored to act as a guide for the striker (15). The middle section of the casting has an enlarged projection to receive a removable holder (7) containing the percussion cap (9). The bottom section of the casting has an enlarged chamber (8) to receive a charge of TNT. The TNT contained in the chamber might be considered as a booster

charge. The chamber is sealed at the bottom of the container by means of the screw-in plug (11). It is probable that the chamber section is a separate fitting screwed into the casting. When in the armed condition, the holder (7) is fitted in the mine so that the percussion cap is positioned below the firing pin (15). The exterior knob on the holder can be adjusted by turning so that the contained

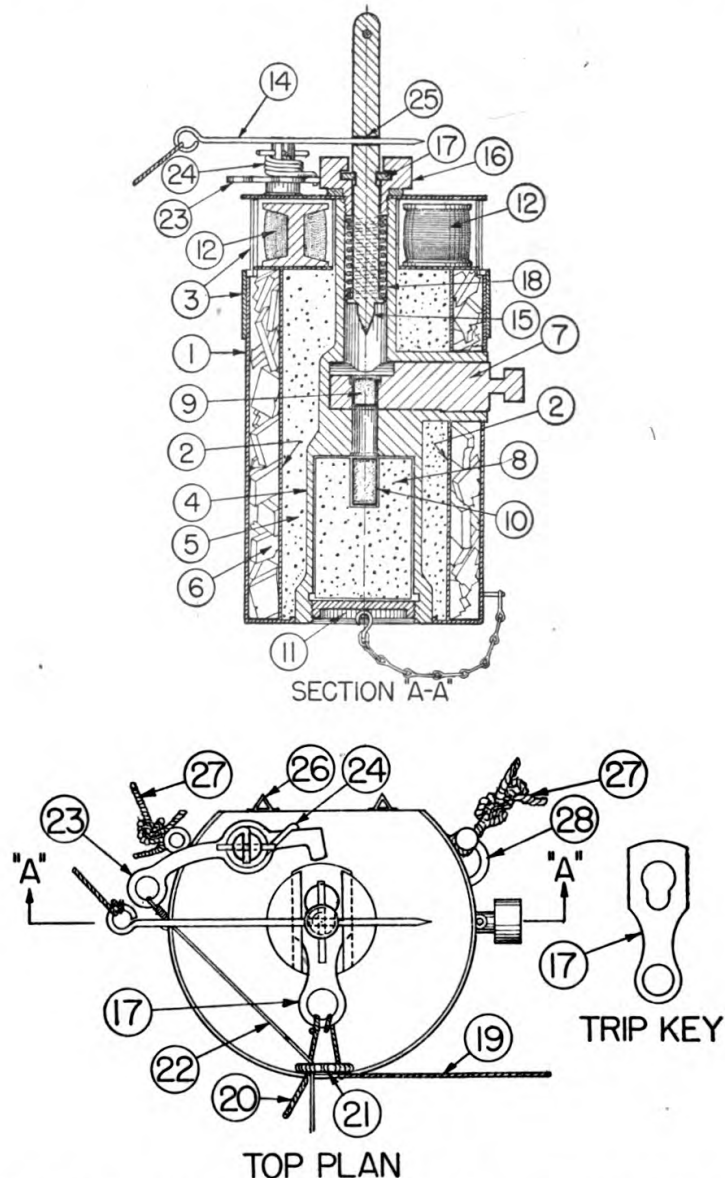

FIGURE 83.—Antipersonnel mine, type B-4—plan and section.

percussion cap is either in a position to be fired by the striker (15) or so the striker cannot penetrate the percussion cap but will strike the holder instead. A mark may be provided on the knob of the holder to indicate its position. The illustration in the original literature is not clear but seems to indicate this mark. The detonator (10) is located below the percussion cap and fits into chamber (8), which

contains TNT. Recesses (12) are provided in the top section and house several spools containing trip lines and attaching cords. The hinged flap (13) covers the recesses and is held in the closed position by the long pin (14), which is also used as a safety pin. The flattened side of the mine has six small pointed projections (26) to assist in attaching the mine to a post or tree. The mine is tied to the post or tree by means of cords (27) attached to the metal rings (28) located near the flat side of the mine. The striker mechanism and safety device are discussed in detail as follows:

(1) *Striker mechanism* (see fig. 83).—The striker passes through a brass collar (16) which is screwed to the top of the casting. The collar is slotted and the striker is grooved to receive a trip key (17) which holds the striker in a cocked position against the pressure of striker spring (18). The trip key is punched with a pear-shaped slot, the diameter of one portion of which is smaller, and the diameter of the other larger, than the large diameter of the striker. In the armed position, the small-diameter section of the slotted hole in the trip key engages the groove in the striker, holding it in cocked position. Two cords (19) and (20), connected to the trip key, pass through the metal guide ring (21) and, when the mine is placed for firing, are anchored at the other end to stakes, trees, or other objects. A tension release wire (22) fastened to the lever (23) also passes through ring (21), and is also anchored at its other end.

(2) *Safety device*.—The mine is safe when the pin (14), having been withdrawn from its position in the flap (13), is placed through the hole (25) in the striker (15). A report received in 1942 states: "There is a second security pin which also passes through the striker, and is withdrawn when the mine is removed from the box in which it is stored." There is no further information to indicate where the second key or pin engages the striker.

b. Employment.—This mine is generally used in antitank mine fields and in wire obstacles for antipersonnel purposes. In antitank mine fields, it is laid in an irregular line in front of the mine field. When these mines are used in wire obstacles, they are spaced at intervals of about 5 yards.

c. Operation.—In the armed condition, the pin (14) is removed from the hole (25) in the striker and the striker is held in a cocked position by the trip key, and the percussion cap is in position under the striker pin (15). The trip key can be moved out of the position in which it engages the groove in the striker by any one or all of the three following actions: a pull on the cord (19) or the cord (20) or a release of the tension wire (22). A pull on cord (19) or cord (20) pulls the trip key outward, thus disengaging the striker.

A break in or release of the tension wire permits the lever (23) to rotate clockwise under the action of the coiled spring (24), thus pushing the trip key outward and disengaging the striker. When the trip key is moved outward, the striker is released and the compressed striker spring propels the striker downward, setting off the percussion cap. This action discharges the detonator, below, and causes the mine to explode.

d. To disarm.—If the mine is not buried, first turn the knob of the percussion cap holder (7) so that the striker pin cannot fire the percussion cap if it should be released, and remove the holder (7) from the mine. Remove the cap from the holder. Then neutralize the striker by inserting the safety pin (14) or a stiff wire in the hole (25). Finally release the cords (19) and (20) attached to the trip key and the wire (22) attached to the lever (23). If the mine is buried, neutralize the striker as described above. Release the cords (19) and (20) and the wire (22). Remove the mine and turn the knob of the percussion cap holder and remove from the mine. Remove the cap from the holder.

e. To arm.—Stretch out the cords in directions necessary to cover the mined area and fix the far ends to posts, bushes, or other objects. Attach the other ends of the pull cords (19) and (20) to the trip key and the other end of the tension release wire (22) to the lever (23). The cords and wire should pass through the guide ring (21). The tension in the pull cords (19) and (20) should be hardly perceptible, while in the release wire it should be sufficient to overcome the action of the coil spring (24), leaving a $\frac{1}{4}$ -inch gap between the nose of the lever (23) and the trip key. Then insert the safety pin into the hole (25) and push the trip key to engage the slots in the striker. Next, insert the percussion cap (9) in the holder (7) and then push the holder into place. The holder should be turned by means of its projecting knob so that the percussion cap is directly below the point of the striker, where it will be fired when the striker is released. Finally, at a safe distance from the mine, withdraw the safety pin by means of a cord attached thereto. The mine is now armed and a pull on either cords (19) or (20), or a break in or release of the tension release wire, will explode the mine.

90. Type 9, improvised, tension-operated (figs. 84 and 85).—This Italian antipersonnel mine is an improvised type prepared by the Italian engineers in the field, and for this reason variations of the type described herein are to be expected. The detonator unit and the striker mechanism, except for the method of releasing the striker, are identical to those used in the antipersonnel mine, type 9, pressure operated (see par. 91).

a. Description.—The mine is inclosed in a wooden box (1) approximately 3 inches wide, 4 inches high, and 13 inches long, and has a wooden cover (2), apparently secured by hooks. The mine consists of an explosive (3) in two blocks, weighing slightly less than 1 pound, a cartridge and detonator unit which fits into a cylindrical body (4), and a striker mechanism, inclosed in a tubular metal guide (5). The detonator cartridge unit is an ordinary nonelectric detonator (6) which seats in the explosive and has its open end fixed into the mouth of a small arms cartridge (7) from which the bullet has been removed. The cylindrical body which supports the cartridge and detonator unit is supported by the wood crosspiece (8). The striker guide (5) is supported on a metal fitting (9) which is screwed to the wood block

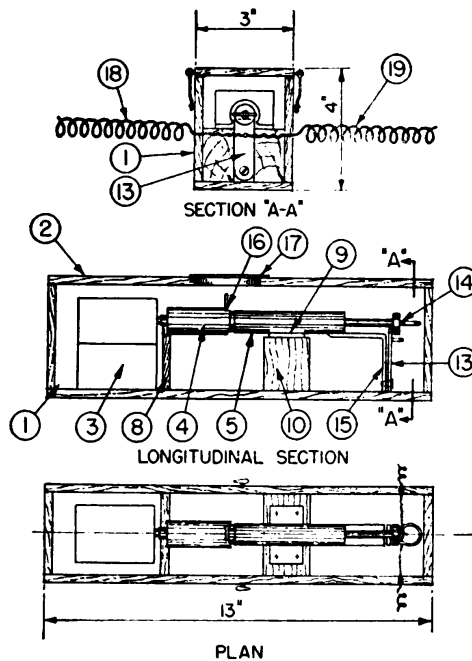

FIGURE 84.—Antipersonnel mine, type 9, tension operated.

support (10). The striker guide is restrained from lateral and longitudinal movement with respect to its supporting metal fitting, but it is capable of being rotated slightly in order that it may be detached from the body. The details of the connection which locks the body to the striker guide are not clear from information available, but an interpretation is shown in the isometric drawing (fig. 85.) The striker mechanism consists of a striker, (11), a striker spring (12), and a trip lever (13). When the striker is in the cocked position and is under compression from the spring, it is held in place by the trip lever, which is turned to the vertical position and bears against the stop nut (14) which is mounted on the end of the striker. The stop nut is provided with a loop handle to assist in the cocking of the

striker. The lever is pivoted at the bottom to a metal angle (15), which is secured to the bottom of the mine box and set to provide partial support for the striker tube (5). A safety strip (16) is provided to fit loosely into a slot formed by the barrel connection between the body and striker guide. With the safety strip in place, the striker is prevented from striking the cartridge. The exact shape of the safety strip is not clear from the information available, but an interpretation is shown in figure 85. An opening with a pivoted lid (17) is provided in the cover of the mine to serve as an access to the safety strip. Two wires (18) and (19) connected to the trip lever pass through holes in the sides of the box and have their far ends attached to external objects so that they will function as pull wires to move the trip lever from its vertical (safe) position and explode the mine.

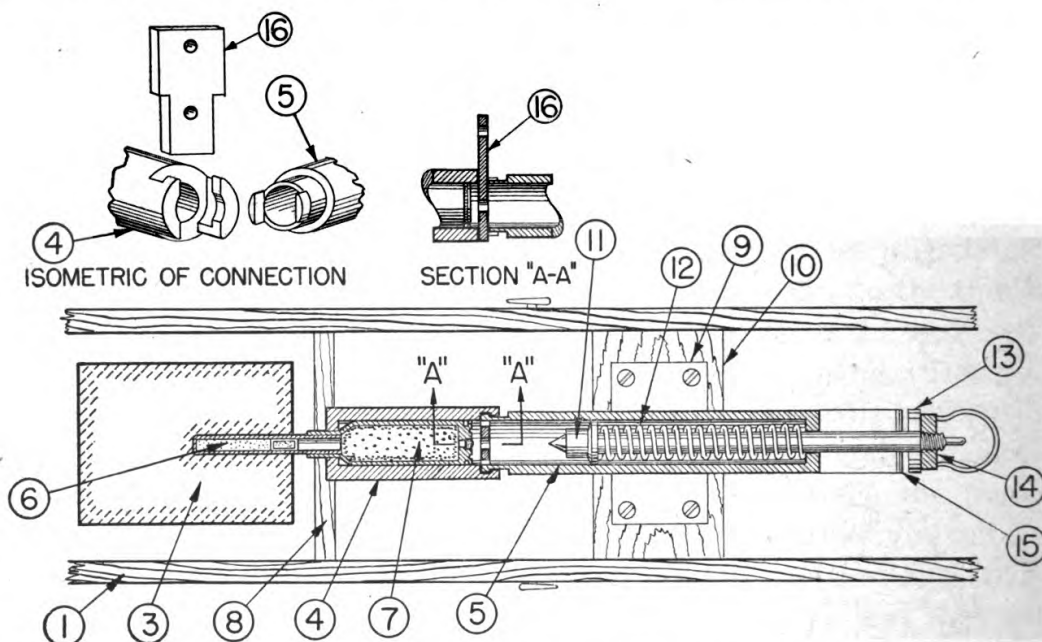

FIGURE 85.—Antipersonnel mine, type 9, tension operated—details.

b. Employment.—There is no specific information available on how the enemy uses this mine. It is apparently suitable for use in minefields where trip wires are feasible.

c. Operation.—When the trip lever is pulled to one side by either pull wire (18) or (19), the trip lever is moved from its vertical (safe) position, thus releasing the striker, provided the safety strip has been removed from the mine. The striker, under pressure from the compressed spring, is propelled against the cartridge, which fires the detonator and in turn explodes the mine.

d. To disarm.—First neutralize the mine by inserting a penknife blade or similar object in the safety slot provided for the safety strip and by making certain that the knife blade or similar object

is capable of intercepting the striker. Next cut the trip wires close to the box without disturbing the trip lever, and remove the cover. Care must be taken in cutting the wires for when one wire is cut, enough tension may exist in the other to throw trip lever. Finally pull on the striker handle (14) sufficiently to release the trip lever and then relax the tension on the handle until striker comes to rest against the stop which has been improvised to take the place of the safety strip. To disarm the mine completely, unlock the striker tube from the body by rotating it slightly and then remove it from the mine. Next, gently pull the detonator cartridge unit from the body, taking care not to use undue force. Finally, reassemble the parts removed from the mine, except the detonator cartridge unit, which should be kept out of the mine until it is rearmed.

e. To arm.—To arm the mine, make sure that the safety strip is in the slot. Run out the trip wires (17) and (18) through the sides of the box and fasten the far ends so that a slight tension is induced in the wires. Remove the striker tube and put the detonator cartridge unit in place. Replace striker tube and lock to body. With safety strip in slot, cock and place the striker so that stop nut (14) bears against the trip lever. Finally, fasten the cover and remove safety strip through the access opening (17).

91. Type 9, pressure-operated (figs. 86 and 87).—This Italian antipersonnel mine is regarded as an improvised mine to be made up by the Italian engineers in the field. For this reason variations of the type described here are to be expected. The detonator unit and the striker mechanism are identical to those used in the anti-tank mine, type 9, pressure operated (see par. 80).

a. Description.—The mine is inclosed in a wooden box (1) approximately 9 inches wide, 5 inches high, and 16 inches long. It has a movable wooden cover (2) which fits over the box of the mine and is supported in some manner so that it is capable of downward movement under pressure. The armed mine weighs $7\frac{3}{4}$ pounds, of which 1 pound is the explosive charge (3) consisting of two blocks of TNT. The mine contains a cartridge and detonator unit which fits into a cylindrical body (4), and a striker mechanism inclosed in a tubular metal guide (5). The detonator cartridge unit is an ordinary nonelectric detonator (6), Italian No. 8 detonator, which is inserted in the explosive and with its open end fixed into the mouth of a small arms cartridge (7) from which the bullet has been removed. The support for the cylindrical body which contains the small arms cartridge is not clearly described in the available literature on this mine. The striker guide (5) is supported on a metal plate (8) secured to a wood filler attached to the bottom of the box. Two bent

metal plates (9) fastened to the base plate (8) support the trip lever (13) at the pivot (10). The striker guide is restrained, in some manner not made clear in available literature on this mine, from lateral and longitudinal movement. However, the striker guide is capable of being rotated to permit its being detached from the body and removed from the mine. The attachment of the striker guide to the body is accomplished by means of an interlocking connection, the details of which are not clear from available information. An interpretation of the interlocking connections is shown in figure 87. The striker mechanism consists of a striker (11), a striker spring (12), and the trip lever (13). The striker is held in the cocked position against the compression of the striker spring by the lower arm of the trip lever, which engages the stop nut (14) mounted on the striker rod (11). In holding the striker, the trip lever tends to turn clockwise, but the rotation is stopped by the lever bearing against the pin (10a). The upper arm of the trip lever bears against a small metal plate (15) on the underside of the mine cover. A safety strip (16) fits loosely into a slot formed by the interlocking connection between the body and striker guide. When the safety strip is in the slot, the striker is prevented from striking the cartridge. The exact shape of the safety strip is not clear from information available, but an interpretation is shown in figure 87. An opening (17) with a pivoted lid is provided in the cover of the mine and serves as an access to withdraw or insert the safety strip.

b. Employment.—These mines are laid with the covers about 6 inches below the ground surface and are ordinarily spaced from 3 to 4 feet apart. They are said to be used principally against personnel. However, the mine has also been classed as an antitank mine. It is probable that the antitank use explains the wide box with the extra side compartments which are capable of receiving additional charges of explosive.

c. Operation.—When pressure is applied on the top of the mine, the cover moves downward and causes the trip lever to rotate about its pivot. By this action, the lower arm of the lever disengages the stop nut, and releases the striker. The striker, under pressure from the compressed spring, is propelled against the cap end of the cartridge, which fires the detonator and in turn explodes the mine.

d. To disarm.—First neutralize the mine by inserting a pen knife blade or a similar object in the safety slot provided for the safety strip, making certain that it is capable of intercepting the striker. Next take such action as it appears necessary from the design of the mine, so as to prevent movement of the cover when opening the lid. Remove the cover carefully and next unlock the striker guide from the

body by rotating it slightly, and remove it from the mine. Then extract the detonator cartridge unit, taking care not to use undue force.

e. To arm.—Insert the detonator cartridge unit in place. Next, with the safety strip in the slot, replace the striker tube. Cock the striker by pulling it outward and then engaging the lower arm of trip lever with the stop nut. Then replace the cover on the mine, being careful not to transmit any pressure on the trip lever in excess of the

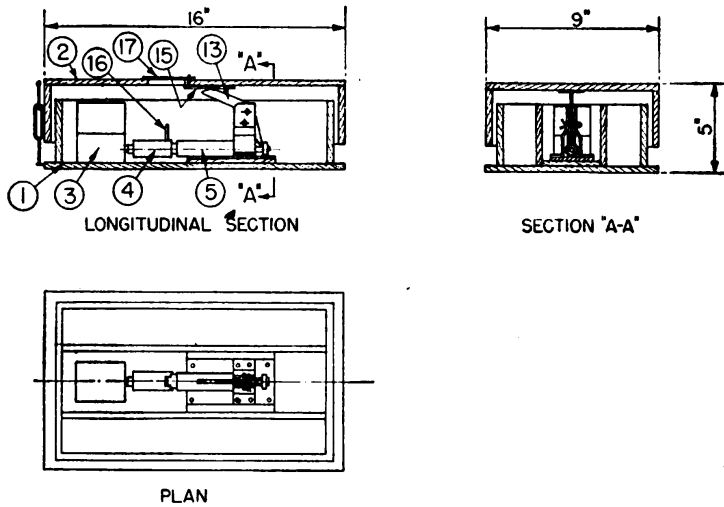

FIGURE 86.—Antipersonnel mine, type 9, pressure operated.

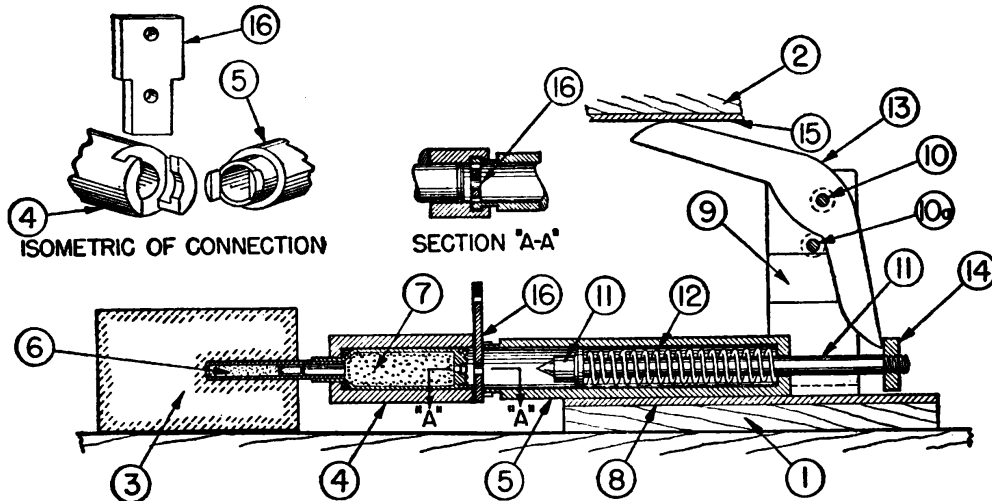

FIGURE 87.—Antipersonnel mine, type 9, pressure operated—details.

weight of the cover. Finally, remove the safety strip from the mine through the access hole (17).

92. Mine improvised from 2-kg. aerial bomb (figs. 88 and 89).—This Italian antipersonnel mine is improvised from the 2-kg. aerial bomb. The complete fuze or igniter as found in the 2-kg. aerial bomb is shown (in part by dotted outline) in figure 88 (A). To adapt this igniter to the requirements of a land mine, the top cover (1a)

together with the safety pin (2a), is unscrewed and removed, and the igniter housing (5) is cemented in place. With this alteration of the igniter, the bomb can be classed as an improvised land mine.

a. Description.—This improvised antipersonnel land mine is cylindrical in shape, $2\frac{3}{4}$ inches in diameter and $4\frac{1}{2}$ inches high. There are two types of this land mine: The type shown in figure 88 (A) discharges pieces of metal shrapnel; the other type, shown in figure 88 (B), discharges steel shot embedded in concrete. The first-mentioned type (fig. 88 (A)) consists of a metal-wrapped canister (1), containing the explosive (3) with a detonator (4). The fitting (6), within which the igniter housing (5) is cemented, is screwed to the

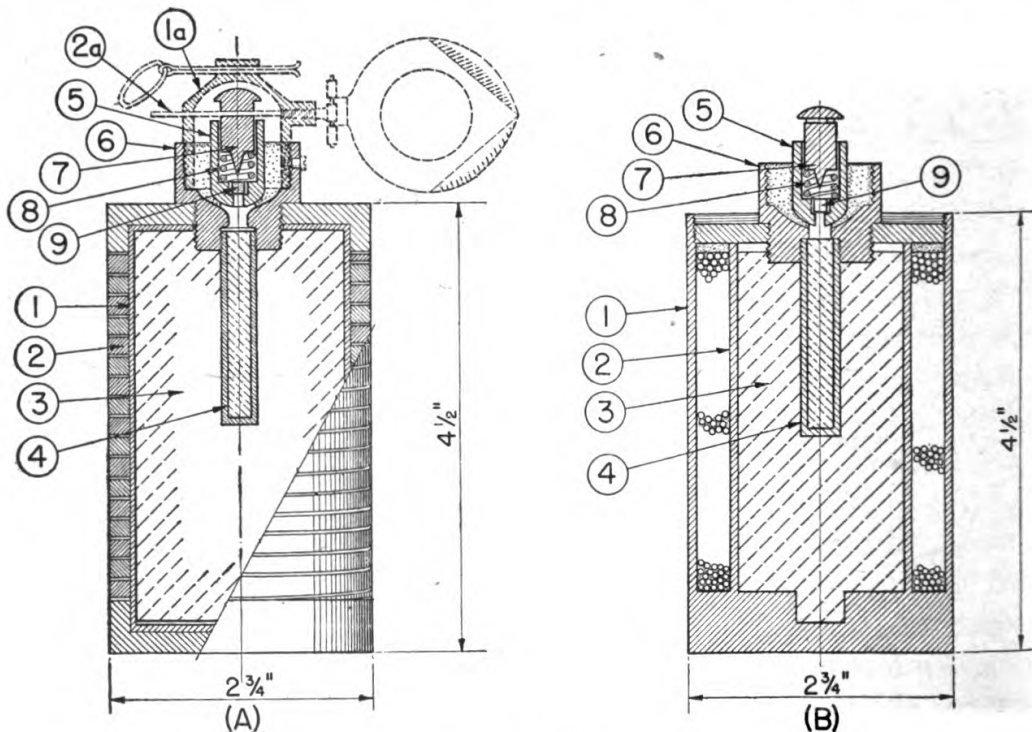

FIGURE 88.

top of the canister (1). The igniter housing (5) seats directly over the detonator and contains the striker (7), striker spring (8), and percussion cap (9). The outside of the canister is wrapped spirally with a strip of metal (2) which breaks up in the form of shrapnel when the mine explodes. The second mentioned type (fig. 88 (B)) consists of a canister (1), an inner canister (2) containing the explosive (3), a detonator (4), and an igniter housing (5) cemented into the fitting (6) which is screwed into the top of the mine. The space between the inner and outer canisters is filled with steel shot embedded in concrete. The explosive charge in the first type (fig. 88 (A)) is slightly greater than that in the second type (fig. 88 (B)). The igniter

housing (5) is identical to that in the first type and contains the same parts, namely the striker (7), striker spring (8), and percussion cap (9) as shown. Another adaptation of the 2-kg. aerial bomb firing device is shown in figure 89. In this case, the igniter of the aerial bomb, shown in figure 88, is altered as follows: The top cover (1a) is removed from the aerial bomb assembly, and the safety pin (2a), the striker (7), and striker spring (8) are detached. The striker head (7) is flattened and tapped (see fig. 89), to take a screw bolt (3a); the top cover (1a) is drilled to pass the bolt (3a). The parts are then re-assembled with the spring (8) fitting over the screw bolt (3a) and on top of the striker (7) which is held in position by the safety shear wire (4a) and the screw bolt. Figure 87 shows the firing device adaptation in the armed condition.

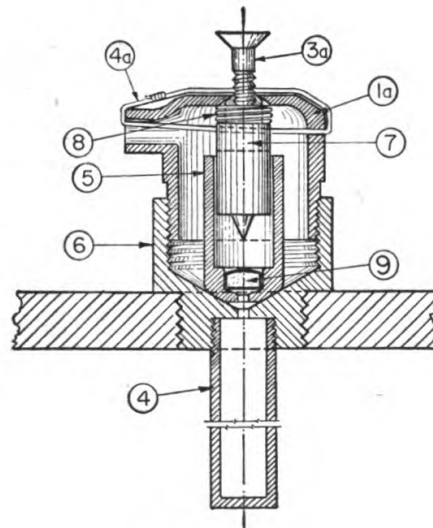

FIGURE 89.

b. Employment.—Although its effectiveness is reduced when buried, this type of mine is especially difficult to detect since only the top of the pressure head need appear above the ground. This type of mine, when exploded, has been known to damage the track bogies of a tank.

c. Operation (fig. 88).—(1) *General.*—When pressure is applied to the striker head, the striker (7) moves down against the compression of the spring (8), and the striker point fires the percussion cap (9). This action explodes the detonator below and causes the mine to explode.

(2) *With altered firing device (fig. 89).*—Pressure on the head of the screw (3a), forces the striker downward shearing the wire (4a), thus releasing the striker (7) which under pressure from the spring (8) above is propelled downward against the percussion cap (9). This action fires the percussion cap (9) and the mine explodes.

d. To disarm (fig. 88).—(1) *General*.—Neutralize the mine by carefully lifting out the striker (7). Unscrew the fitting (6) from the mine and lift it out complete with the detonator (4).

(2) *With altered firing device* (fig. 89).—If the shear wire (4a) is broken, the mine may be too dangerous to handle. If found in this condition, it would probably mean that the percussion cap (9) has failed to fire because it was defective. If found with the safety shear wire intact, the striker (7) should be secured from further downward movement by gently pulling up the screw (3a) and binding it with string or thin wire. Then unscrew the igniter housing (1a) and lift it out of the mine, complete with the striker. Finally, unscrew the fitting (6) and remove it, complete with the detonator (4).

e. To arm (fig. 88).—(1) *General*.—The fitting (6) together with the detonator (4) and igniter housing (5) containing the cap (9) should be screwed into the mine. The striker spring (8) and striker (7) are placed in position as shown.

(2) *With altered firing device* (fig. 89).—The igniter complete with cover (1a) fitting (6), the safety shear wire (4a), and the percussion cap and detonator should first be assembled in the fitting (6). The complete assembly should then be screwed into the mine, taking the necessary precautions to avoid shearing the safety shear wire (4a).

93. Electric mine, type 2 (fig. 90).—This Italian mine is an electrically-fired improvised mine. The design of the mine may vary considerably from that described, but the underlying principle may be expected to be the same. It is recommended that they be exploded in place. In the event exploding the mine in place is not feasible, it should be neutralized and removed, as described in *d* below, by trained personnel.

a. Description.—This antipersonnel mine is cylindrical in shape and somewhat resembles a very small drum or container. The container is a metal cylindrical body (1) with a wood base (2) secured to the bottom of the body (1), and a tight fitting wood cover (3). The mine generally contains 4 pounds of TNT explosive (4). Fitted into the wood base, there is an electrical detonator (5) seated in the top of the explosive, and a 4½-volt battery (6) which is apparently secured to the wood cover. The battery supplies the energy for exploding the detonator which is connected to the battery by a wire and metal conductor circuit. A short wire (7) from one of the battery terminals to the detonator forms one branch of the circuit. The other branch of the circuit is formed by the wire (8), the receptacle (9) and the bridging plug (10), the wire

(11), the metal collar (12), the metal rod (13) and the wire (14). The circuit from the battery to the detonator is completed when the metal rod is in contact with the metal collar, and when the bridging plug is in place in the receptacle. The wire (8) passes up through the top of the mine to the receptacle, and the wire (11) which is the return from the receptacle connects to the metal collar which is fixed to the top of the mine. Outside of the mine, the wires (8) and (11) are probably inclosed in a common exterior covering, and with the receptacle form a test lead. The metal rod is supported by a short rubber tube (15) fitting over the metal collar, and passes through a hole, which serves as a guide, in a metal plate (16) at the under side of the cover. The bottom of the steel rod below the guide in the plate is connected to the detonator by

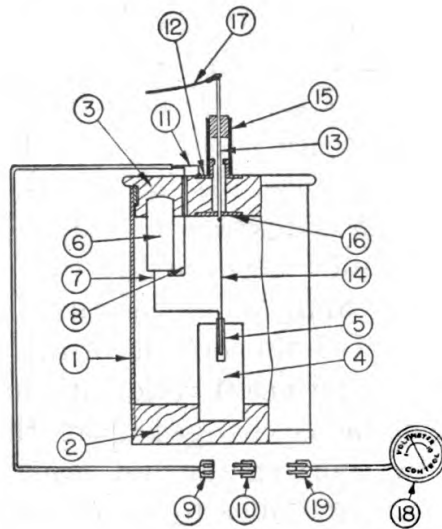

FIGURE 90.

a wire (14). A trip wire (17) is secured to the top of the steel rod. When the trip wire is pulled the steel rod, which is free to cant from its normal vertical position by virtue of the flexible rubber support (15), and the metal collar are brought in contact and the electrical circuit is closed. The bridging plug constitutes the safety device, because when it is removed, the electrical circuit is broken. A voltmeter (18) with wire leads and plug (19) is used to test the circuit.

b. Employment.—There is no specific information available on the employment of this mine. Although only one trip wire (16) is shown attached to the metal rod (14) which initiates the firing of the mine, it is possible to use additional wires.

c. Operation.—When the trip wire is pulled, the metal rod is canted to one side until it contacts the metal collar, thus closing the

circuit (this action is similar to throwing a switch). The battery current then passes through the electric detonator, causing it to explode and detonate the mine.

d. To disarm.—The disarming of the mine must be done by trained personnel and then only when it is not feasible to explode it in place. To neutralize the mine, proceed as follows: The trip wire should first be cut with scissors or pliers, using extreme care that no additional tension is produced in the wire which might bend the metal rod thus completing the circuit. The outside of the mine should next be examined to locate the test leads which generally will be found to enter the mine at the top. Although it appears that the bridging plug may next be removed to break the circuit, for some reason the instructions covering the use of the mine make no mention of this method of breaking the circuit, but instead, give instructions to cut each wire (8) and (11) of the test lead separately and coil them apart. If the wires are fastened together or have a common exterior covering, the wires should be separated before cutting. Extreme care should be used to avoid disturbing the steel rod or the rubber tube. It is important to keep the above instructions in mind since simultaneous cutting of both wires may produce an electrical contact between the two wires (8) and (11), thus shorting the circuit and, under certain circumstances, exploding the mine. Shorting of the circuit ordinarily would have no effect unless the rod and the metal collar are in contact. However, if the wiring in the mine is changed from that shown, the mine may explode merely by shorting the test lead. There is no information available on the procedure to be followed for the complete disarming of the mine and since very little is known of its construction, no attempt is made here to prescribe the procedure for the complete disarming or disassembling of the mine.

e. To arm.—There is no information available on rearming this mine, probably because its reuse is not recommended. If the mine should be neutralized and disarmed, as described in the previous paragraph, the desirability and method of rearming should be decided upon only by trained personnel. In the event the mine is properly armed, a voltmeter test may be made, which test is described as follows: The purpose of the test is to determine the battery voltage, and to test the continuity of the circuit. To test the mine, remove the bridging plug, connect the voltmeter to the receptacle, and pull the metal rod to the side so that it makes contact with the metal collar. If the circuit is complete, full battery voltage will register on the voltmeter. Although the full voltage exists in the circuit during the test, the flow of electricity (amperes) will depend

upon the resistance in the voltmeter. Therefore, the voltmeter used must have sufficient resistance to reduce the current to that amount which is safe to pass through the detonator without exploding it.

SECTION V

DUAL PURPOSE MINE

Road and field mine..... Paragraph 94

94. Road and field mine (figs. 91 and 92).—This is a type of Italian mine which may be used either as an antipersonnel, antivehicle, or as an antitank mine. The title “road and field mine” by which this mine is known, emphasizes the double use to which it may be put.

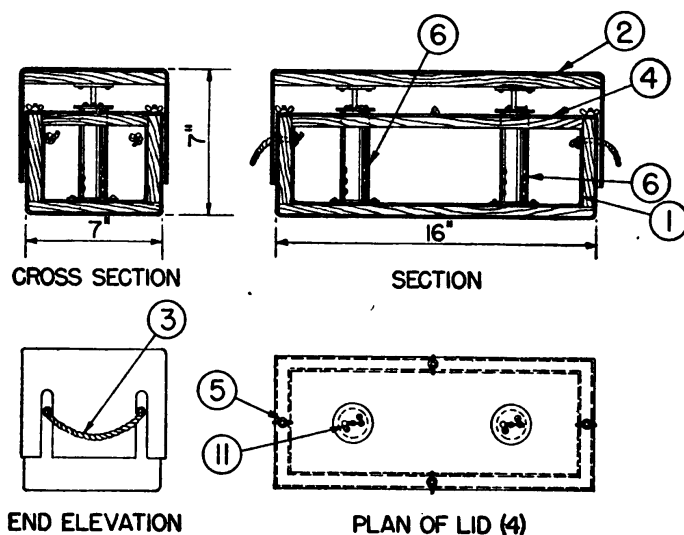

FIGURE 91.

a. Description.—This mine is rectangular in shape and when assembled and armed measures 7 inches in height, 7 inches in width, and 16 inches in length. The container or box (1), (see fig. 91), is made of wood covered with sheet metal inside and outside, and has a wooden lid (4) which is covered with sheet metal on the outside. A sheet metal pressure cover (2), reinforced with wood for rigidity, fits over the box (1). This pressure cover is slotted at the ends to clear the rope handles (3). The lid (4) of the box is held in place by four wing nuts (5). The box contains the explosive, which is gelignite or similar explosive, packed in cartridges. Two wood tubes (6) are secured to the bottom of the box and protrude through and above the lid. These tubes are bored (and perhaps lined) to receive a striker mechanism and an exploder cartridge (7) (see fig. 92). The striker mechanism consists of a striker (8), striker spring (9),

and a striker supporting plate (10) which is engaged by two retaining screws to the top of tube (6) by means of the catch slots (11). The striker is provided with a shoulder to support the striker spring (9). The striker is cocked by pulling the striker in opposition to the compression of the striker spring and is retained in the cocked position by inserting a copper shear wire through the hole (12). When used to damage light traffic or for antipersonnel use, the copper shear wire is slightly less than $\frac{1}{16}$ inch in diameter (about No. 16 gage). When used as an antitank mine, the shear wire is slightly more than $\frac{1}{16}$ inch in diameter (about No. 12 gage). A metal pressure plate (13), about $2\frac{1}{2}$ inches square, is fixed to the top end of

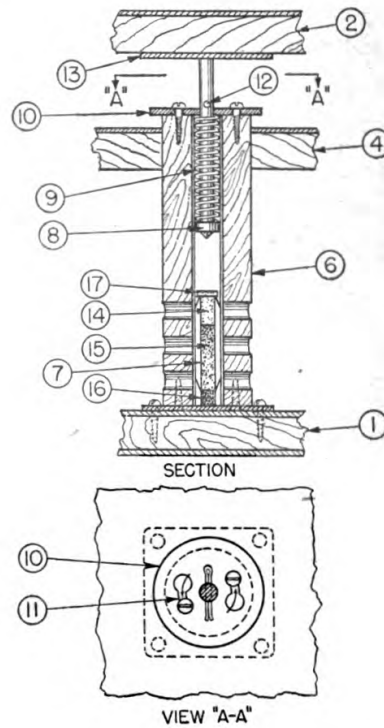

FIGURE 92.

the striker and supports the pressure cover (2). The exploder cartridge (7) is a cylinder approximately $1\frac{1}{2}$ inches in diameter and 5 inches long. It may be of the percussion or chemical type. The percussion type igniter or exploder for this mine is improvised from a cartridge which consists of a percussion cap and detonator. A model 1891 cartridge is emptied of its bullet and propellant. A charge of black powder (14) is placed in the empty cartridge and the detonator (15) is inserted with the open end of detonator against the powder. The open end (16) of the cartridge is then closed with a plaster and cotton wool pad and is varnished black. The other end (17), which is the cap end of the cartridge, is painted red and is uppermost

when the cartridge is inserted in the mine. No information on the chemical type of exploder is available.

b. Employment.—The mine is armed to operate against tanks (heavy traffic) or to operate against personnel or light traffic when the mine is laid. The mines are laid in holes about 9 or 10 inches deep and are covered with loose earth.

c. Operation.—Pressure on the pressure cover forces the striker downward, shearing the copper shear wire at (12) and thereby releasing the striker. The striker, under pressure from the compressed striker spring above, is propelled downward against the cap end (17) of cartridge below, detonating the mine.

d. To disarm.—Neutralize the mine by first carefully removing the pressure cover and then extracting the striker assembly. This is done by giving the striker supporting plate a part turn to disengage it from the two retaining screws. To disarm the mine completely, continue in the following order: Unscrew the wing nuts and lift out the lid; remove the tubes with exploder cartridge in place; and then remove the exploder cartridge. Finally, reassemble the mine without the exploder cartridge and with the striker in an uncocked condition.

e. To arm.—Cock the striker. Insert in the hole, the size of copper shear wire required to suit the intended use. Continue in the following order: Turn the striker supporting plate counterclockwise to release slot from fastenings, and remove the striker assembly; insert the cap-detonator cartridge (red end uppermost); then replace cocked striker assembly, and finally place cover carefully over the mine.

SECTION VI

BOOBY TRAPS

General-----	Paragraph
	95

95. General.—The Italians depend largely upon their standard antipersonnel mines for booby trap installations. Among the more important may be mentioned the type B-4 and the 2-kg. antipersonnel mines discussed in paragraphs 89 and 92. A booby trap found in the Bardia area had the form of a single earphone headset, and exploded when the nickel-plated screw at the back of the earpiece was unscrewed. It may have been intended to explode when the current was applied, as in normal use. The same locations must be investigated and the same care taken as for German booby traps when in localities containing Italian booby traps. In North Africa, wherever a notice board with a skull and crossbones painted on it has been found, booby traps have been found in the immediate area.

CHAPTER 4

JAPANESE LAND MINES AND DEVICES

SECTION I. Firing device and detonator	Paragraph 96
II. Antitank mines	97-101

SECTION I

FIRING DEVICE AND DETONATOR

Combined friction igniter and detonator	Paragraph 96
---	--------------

96. Combined friction igniter and detonator (fig. 93).—This combined friction igniter and detonator is designed for use in the land mines, described in paragraphs 98 and 99.

a. Description.—The combined igniter-detonator is made up of a detonator and a friction igniter. The detonator tube (1) is $2\frac{3}{4}$ inches

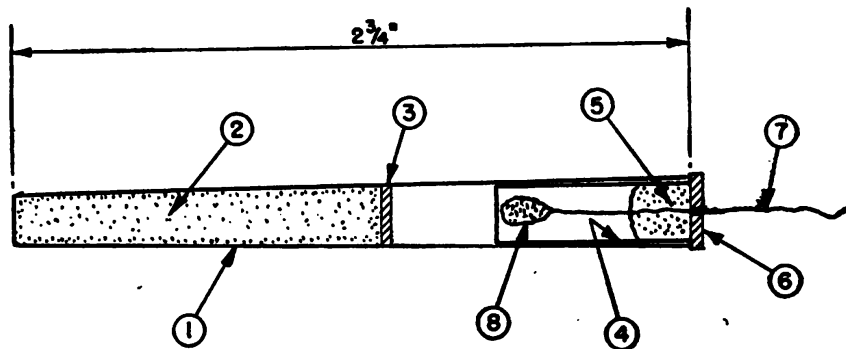

FIGURE 93.

long and is made of stiff prepared paper. The tube contains an explosive filling (2) which is retained by a disk (3) of unknown composition. In the open end of the detonator tube is inserted the friction igniter. The tube (4) of the friction igniter is also made of some kind of stiff paper. It contains a friction igniter composition (5) and is sealed by a capping disk (6) of unknown material. Through the composition and the disk passes the friction wire (7). Within the igniter tube the end of the wire is cemented or cast into an oval friction ball (8) composed of powdered glass and a reddish colored cement.

b. Operation.—When the wire is pulled the friction ball is pulled through the igniter composition and the friction created ignites the

composition. The flame created by the igniter fires the explosive filling of the detonator.

c. To Neutralize.—The combined igniter-detonator cannot be neutralized by means of locking devices, but it can be rendered harmless by cutting the wire close to the capping disk. The igniter tube may also be removed from the detonator tube if the two tubes are not glued or cemented together.

SECTION II

ANTITANK MINES

	Paragraph
General.....	97
Friction-ignition land mine.....	98
Pressure and traction land mine.....	99
Antitank mine.....	100
Magnetic antitank mine.....	101

97. General.—The Japanese land mines described in paragraphs 98 and 99 seem to be improvised mines and are primitive in construction. It is stated they were used in Kwangsi, China, during the September 1940 campaign. The use of a wooden container has an advantage over the use of a steel container as it does not cause any reaction on electro-magnetic locating instruments.

98. Friction-ignition land mine (fig. 94).—*a. Description.*—The Japanese friction-ignition land mine is a mine fired by a friction pull igniter. It is enclosed in a wooden box (1), whose internal dimensions are approximately 3 inches by 13 inches by $2\frac{3}{8}$ inches. The box (1) is divided into two compartments by a wood partition (2). The larger compartment contains five stabs of “yellow explosive” (3), probably picric or TNT. The total charge weighs $3\frac{1}{2}$ pounds. A friction igniter and detonator (4) is mounted in a hole in the partition with the detonator inserted in the end slab of the explosive. The pull wire (5) of the igniter is threaded through a looped wire support (6) and is fastened to one looped end of a pull rod (7) which passes through an opening in the end wall of the box. The projecting looped end of the pull rod has a pull trip wire (8) attached, which is fastened to a tree or stake or other convenient object. A safety device (9) is provided to lock the pull rod in position at the point where it passes through the end wall of the box. Information on this safety device is vague. In the original source of information, a combination of a “bottle cap” and No. 14 gage wire is used. A cork may also be used, and this is shown in the figure. An antilifting device consists of the wire (10) fastened to the wire (5) and threaded through a hole in the floor of the box to

a stake (11) previously driven into the ground before laying the mine.

b. Employment.—No definite information is available as to the use of this mine.

c. Operation.—A pull on the trip wire, or a pull on the wire (10) caused by lifting the box, will cause the friction igniter to flash and fire the detonator which in turn explodes the charge.

d. To disarm.—Cut the trip wire. Carefully remove the soil where the trip wire enters the ground to the buried mine, taking due care not to exert any pull on the remaining length of the trip wire or the pull rod. Wedge the pull rod firmly in place where it emerges from the box. Without disturbing the box, cut the wire (10) just below the bottom of the box. Remove or pry off the lid and cut the wire (5). Carefully withdraw the combined friction igniter and the detonator tube. Then separate the igniter from the detonator.

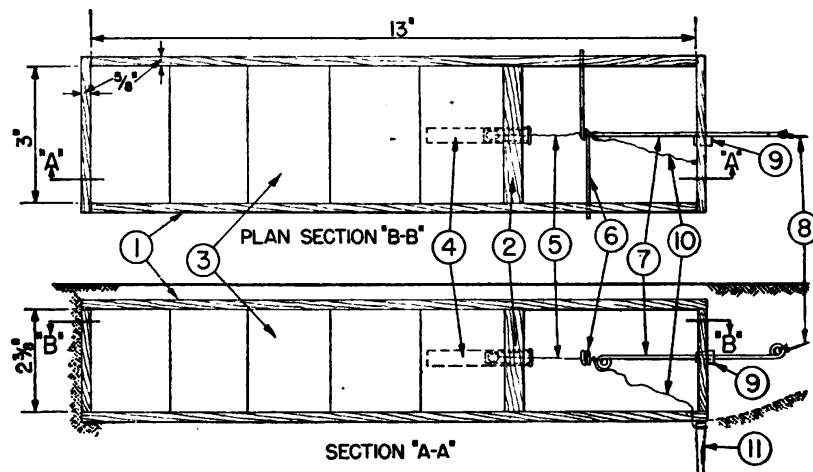

FIGURE 94.

e. To arm.—First, drive the stake into the hole prepared for the mine. Tie wire (10) to the stake and thread it into the box when the latter is laid in place. Attach one end of the trip wire to the pull rod and the other end to a distant tree or other object. Make sure that there is no tension in the trip wire. Insert the combined friction igniter and detonator tube into the charge through the hole in the board. Thread the igniter pull wire through the loop of the supporting wire and tie it to the loop of the pull rod. Tie the activating thread (10) to the igniter pull string (5). Finally, remove the safety device (9) and fill the excavated hole to the level of the surrounding ground, leaving only the trip wire (8) above the surface of the ground.

99. Pressure and traction land mine (fig. 95).—*a. Description.*—This Japanese mine is inclosed in a wooden box (1) whose internal dimensions are approximately 12½ inches by 9½ inches by

9½ inches by 7 inches. The box has a lid (2) which is supported by four compression springs (3) (No. 12 gage) and held in place by the rabbet strips (4) which are fastened to the top edges of the box. A 2-pound charge (5) of "yellow explosive," probably picric or TNT, in three blocks is laid along one end wall. It appears that the charge is inclosed in a container whose make-up is not given in the available information. A friction-igniter and detonator (6) similar to that used in the friction-ignition land mine (see par. 98) is inserted through an opening in the charge container, into the center block of the charge. A pull wire (7) attached to the friction-igniter is passed under a wire hook (8) and up through a coiled wire guide (9), and is tied to the loop on the free end of a pivoted wire rod (10). The rod pivots about an eye screw fixed into the side of the box. The hook and guide are mounted on the floor of the box. A wire or cord (11) which acts as a trip wire is threaded through a hole in the lid, fastened to the rod and threaded through a hole (12) in the floor

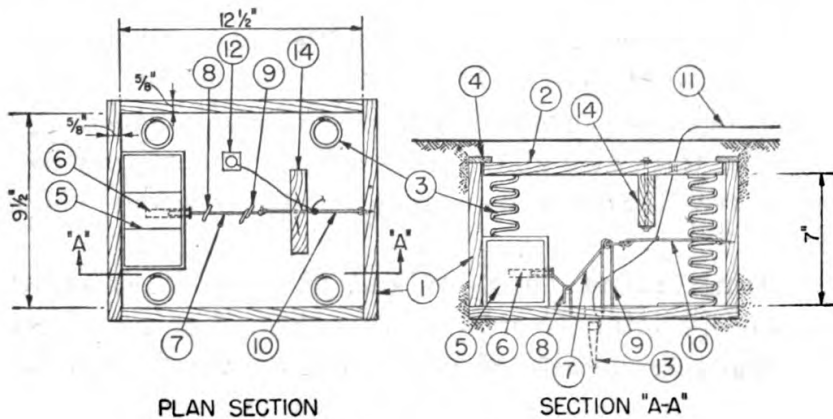

FIGURE 95.

of the box and is fastened to a stake (13) driven into the ground underneath the mine. A pressure block (14) is mounted on the under side of the lid by two short bolts and is centered above the rod.

b. Employment.—No information is available as to the uses to which this mine is put. It is assumed that it may be used as a road mine or placed in trails as an antipersonnel mine. By increasing the size of the box (1) the amount of explosive can be increased to make the mine effective for antitank use.

c. Operation.—This mine can be exploded by three methods: first, it can be fired by the trip wire (11) whose free end is attached to a tree, stake, or other convenient object. Second, it can be fired by lifting the box (1) and exerting a pull on the portion of the trip wire fastened to the stake (13). Third, it can be fired by pressing on the lid whereupon the block (14) depresses the pivoted rod. In all three

cases the movement of the rod by either pull or push causes a pull in the wire (7) which fires the igniter and explodes the charge.

d. To disarm.—Carefully cut the trip wire and remove the lid, avoiding the application of pressure. Cut the wire (7) and then the portion of the trip wire between the pivoted rod and the stake. Remove the friction-igniter and detonator, and, if possible, separate the friction-igniter tube from the detonator tube.

e. To arm.—Although no information is available as to the arming procedure, the following steps in arming are suggested: drive the stake into the excavated hole and lay the mine in the hole so that the stake is just under the hole of the box. Tie the trip wire to the rod, after threading it through the lid. Tie the loose end of the wire (11) to the stake. Insert the friction-igniter and detonator in the hole provided in the charge. Pass the wire (7) under the wire hook and through the coiled wire and tie it to the rod. In fastening the wire to the rod care must be taken that no tension is applied to the wire. The lid is then set in place on the springs and the retaining strips fastened in place. Great care must be taken not to depress the lid below the rim of the box. The mine is then covered and the hole filled to the level of the original surface and camouflaged as desired, leaving only the trip wire above the surface. The trip wire is then attached to a tree or other convenient object without placing any tension in it.

100. Antitank mine (figs. 96 and 97).—*a. Description.*—This Japanese antitank mine is a pressure operated mine. Precise information regarding details of construction is not available. The mine is contained in a cylindrical container (1) about $6\frac{1}{2}$ inches in diameter and $1\frac{3}{8}$ inches high, and is apparently made of tin, painted brown. The container is divided into two parts, the top part screws over the bottom by means of large right-hand threads. Attached to the sides of the container are four brass rings (2) which are used for anchoring or carrying the mine. Within the container are found two types of explosive charge. These are separated by a cardboard cylinder (3). The inner compartment contains a flaky yellow explosive (4) loosely packed. The outer compartment is filled with a darker yellow explosive (5) tightly compressed. The entire charge, amounting to about 2 pounds in weight, assuming a density of TNT, is wrapped in heavy yellow paper bound with muslin. In the center of the mine is inserted the fuze (6) which has a projecting cover (7). The exact construction of the fuze is not known, but it consists of a threaded cap, a striker with striker spring, a threaded collar and threaded base which contains the detonator, a shear pin about $\frac{1}{8}$ inch in diameter, all inclosed in a brass cylindrical body.

b. Employment.—This mine has been used in road blocks and figure 97 illustrates a pattern of mines found in a Philippine road. A five-passenger sedan has been known to pass over the mine without detonating it. When detonated, however, the mine is capable of breaking the treads on a tank.

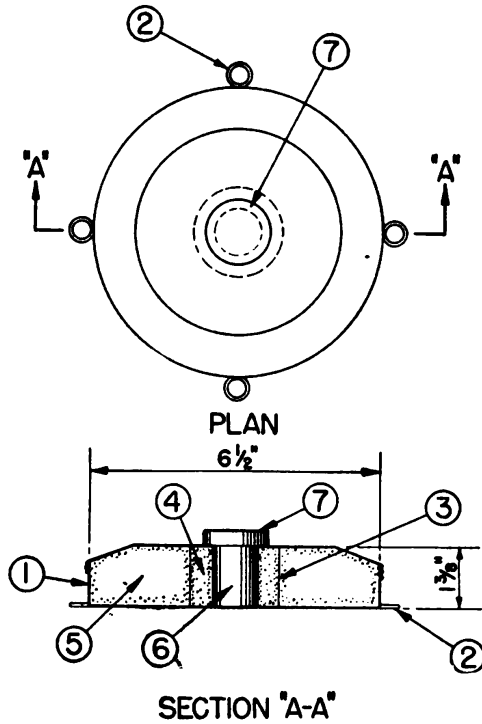

FIGURE 96.

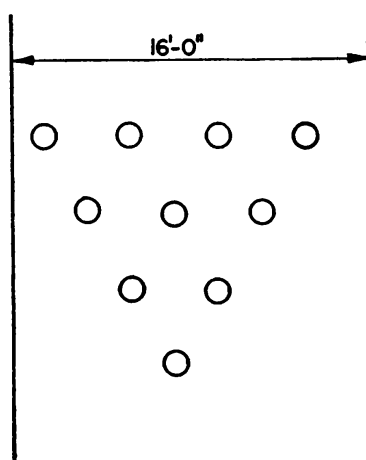

FIGURE 97.

c. Operation.—Pressure on the fuze cover shears the shear pin and the fuze is detonated. In turn, the charges (4) and (5) are exploded.

d. To disarm.—The method of disarming this mine is not known. However, removing the fuze cover is said to render the mine comparatively safe.

101. Magnetic antitank mine (figs. 98 and 99).—The Japanese magnetic antitank mine differs from the usual type of antitank mine in that it is designed to be thrown like a grenade. It is carried in a canvass pouch which opens at the top and is fastened by a snap fastener. The pouch is carried by means of a belt loop attached to it. Available information on the mine is not clear as to all the detailed construction of the mine. It appears that the magnets

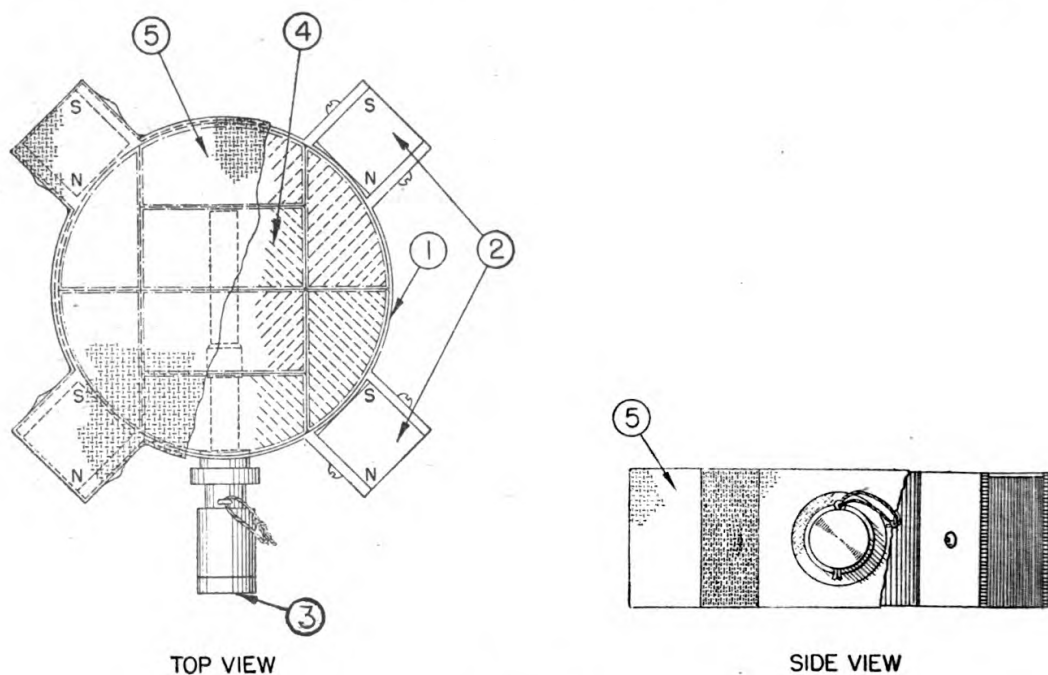

FIGURE 98.

are for the purpose of holding the mine against a tank or other metallic vehicle. Whether the magnets are effective for this purpose is not disclosed by available information.

a. Description.—The magnetic antitank mine consists of a cylindrical body (1), four permanent magnets (2), and an igniter assembly (3). It weighs about $2\frac{1}{2}$ pounds, of which $1\frac{1}{2}$ pounds is the explosive charge. The cylindrical body is $4\frac{3}{4}$ inches in diameter and $1\frac{7}{8}$ inches high. It is composed of eight cast blocks of explosive (4) wrapped individually in waxed paper. The explosive consists, essentially, of two equal parts of trinitro anisole and hexanitro diphenylamine. Equidistant around the perimeter of the body are attached four magnets whose strength has not been as-

certained. The explosive charge together with the magnets is covered by a khaki-colored canvas cover (5) which is partially shown in Figure 98. On an axis midway between two of the magnets, an igniter assembly (3) is inserted into the body through preformed holes in the adjacent blocks of explosive. The exact construction of the igniter assembly is not clear from the field sketches in the source of information. However, as shown in the detailed section (see fig. 99), it consists primarily of an igniter, a delay fuze, and a detonator. Within the igniter, a striker (6) is held in the cocked position by four steel balls (7) and the compression of the striker spring (8). A sliding cap (9) with an internal annular groove (10) fits over the shouldered end of the tube (11) and is held in place by the compression of spring (12). A safety pin (13) with a pull cord loop (14) is located just below the sliding cap and prevents it from being accidentally depressed. The tube houses a per-

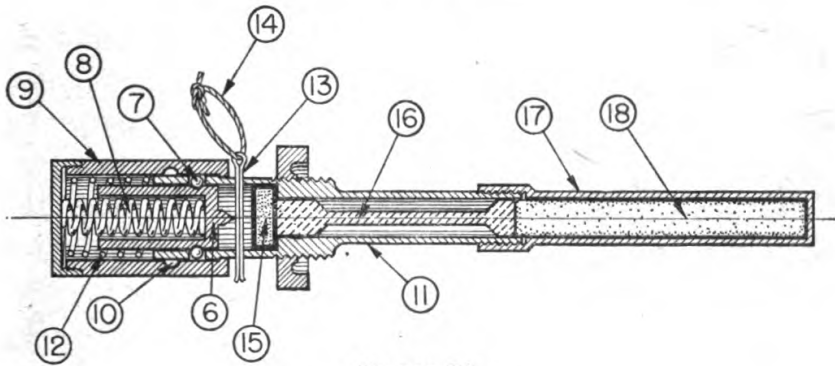

FIGURE 99.

cussion cap (15) and the delay fuze (16) and acts as a guide for the striker. The fuze has a delay of about 6 seconds. To the bottom of the tube is attached the detonator tube (17) containing the detonator charge (18).

b. Employment.—These mines are used to attack the weak points of the tank by throwing it against such parts as the joints, engine compartment, and the under side of the tank. It is used by flamethrowers to stop the tank and then render it untenable to the crew which would attempt to escape and thus become casualties. Another probable use of the mine is to attach it to the under side of the tank as it goes over a trench or fox hole. This would probably stop the tank and make it easy for artillery and antitank weapons to destroy it.

c. Operation.—The mine operates on the hand grenade principle. It is removed from the pouch and the safety pin is pulled out. When the operator is ready to throw the mine against the tank, he pushes the cap inward against the pressure of the spring (12).

The pressure of spring (8) forces the balls into the groove, and the striker is thrust against the percussion cap which is fired. The cap ignites the delay fuze and 6 seconds afterwards, the detonator is fired and the charge is exploded.

d. To disarm.—To disarm the mine, first neutralize the igniter by inserting the safety pin or a nail in the safety pin hole. Then unscrew the igniter assembly from the mine. To render the igniter assembly relatively safe to handle, remove the detonator tube from the tube.

CHAPTER 5

FRENCH TYPE MINES AS CAPTURED OR PRODUCED BY THE GERMANS

French light antitank mine..... Paragraph
102

102. French light antitank mine (figs. 100 and 101).—Reports indicate the existence of a number of French light antitank mines all of the same general design, but differing in size, weight, and type of metal used in their construction. Considerable stocks of these mines were taken over by the Germans after June 1940. It has been reported that these mines have been used by the Germans on numerous occasions, in the Middle East. A description of one type of French light antitank mine on which fairly complete information is available is given below.

a. Description.—This French light antitank mine is rectangular in shape and its body is $9\frac{1}{2}$ inches long by $5\frac{1}{2}$ inches wide by $4\frac{1}{2}$ inches high. Its flanged base is $12\frac{3}{4}$ inches long by $8\frac{3}{4}$ inches wide. The mine weighs approximately $14\frac{1}{2}$ pounds, of which $5\frac{3}{4}$ pounds is the high explosive charge. Following is a detailed description of the principal parts:

(1) *Container.*—The container (1) is rectangular in shape and has a flanged base. It is $2\frac{1}{2}$ inches high and is constructed of pressed sheet steel $\frac{1}{10}$ inch thick. To the base of the container are attached three chains (2) which are designed to hold the cover in place. On one end of the mine there is a chain (2) with a loop (3) for attaching this chain to the cover (4). At the other end of the mine are two chains (2) which are fixed to the cover. Holes are punched in the four corners of the base and are used to stake down the mine. Symmetrically located within the container are two cylindrical tubes (5). The upper portion of the tube is threaded to receive the igniter assembly (6) and the lower portion holds a booster charge (7). The booster charge is contained in a metal box which is shaped to receive the lower portion of the igniter assembly and is separated from it by the washer (8). When the igniter assembly is not in place, the opening of the tube is closed by either a screw plug or a fitted plug. Surrounding the tubes is the explosive charge (9) which is poured through a hole in the side of the container. The filling hole is sealed by the screw plug (10).

(2) *Cover*.—The cover of the mine is made of pressed sheet steel $\frac{1}{10}$ inch thick, and has a corrugated top. The cover is stiffened by means of a metal strip (11) and the channel shaped stiffeners (12) which are welded to it. In a central hole of the stiffeners is welded a metal cup (13) which fits over the striker head of the igniter assembly when the mine is in the armed position. An aluminum channel safety bar (14) passes longitudinally through the cover and rests on the igniters without exerting any pressure on the striker heads. At one end of the safety bar is a safety pin (15) which prevents the bar

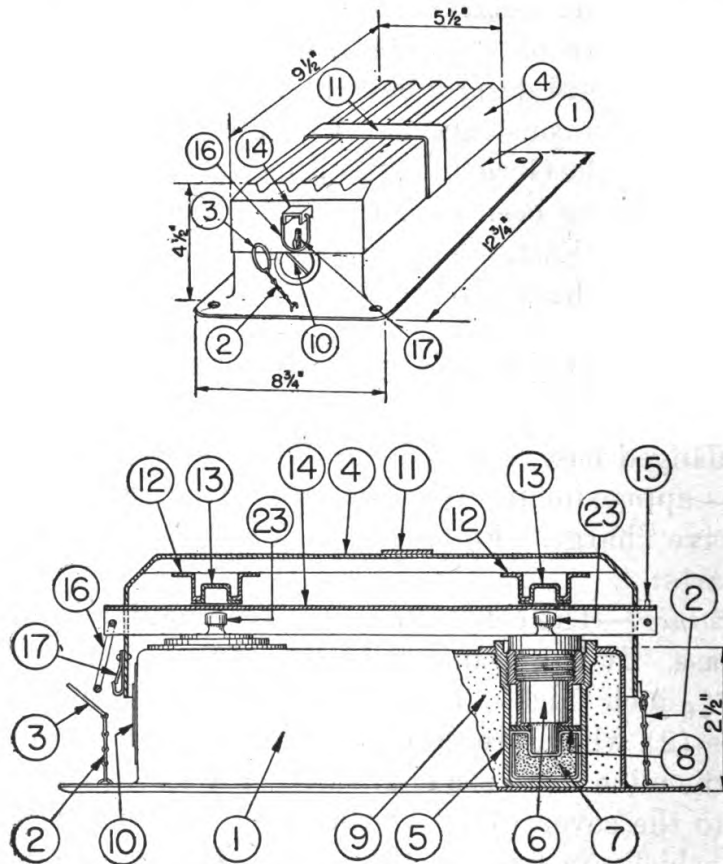

FIGURE 100.

from accidentally dropping out of the cover and at the other end is a pull ring (16). On the end of the cover is riveted a clip (17) to which is fastened the chain ring when the mine is laid.

(3) *Igniter assembly*.—The igniter assembly shown in figure 101 is housed in a cylindrical body composed of three parts. The upper part (18) houses the striker mechanism and is threaded externally to permit the igniter assembly to be screwed into the tube (5) of the container (1). The middle part (19) acts as a guide for the striker and connects the upper part to the lower part (20) which holds the detonator (21) and its retaining spring (22). The striker (23) is held

in a cocked position against the compression of the striker spring (24) by the shear pin (25). The percussion cap (26) is retained in the container (27) by means of a screw ring (28). The container is held in place by means of a washer (29) which is screwed between the parts (19) and (20). There are two types of igniter assemblies used in this mine. They are both the same in detail, but differ as follows: The one, known as the 1935 model, is made of steel and brass. It has a brass shear pin (25) which is $\frac{36}{100}$ inch in diameter and shears under a pressure of 500 pounds. The other igniter assembly, known as the 1936 model, is made of aluminum alloy. It has a brass shear

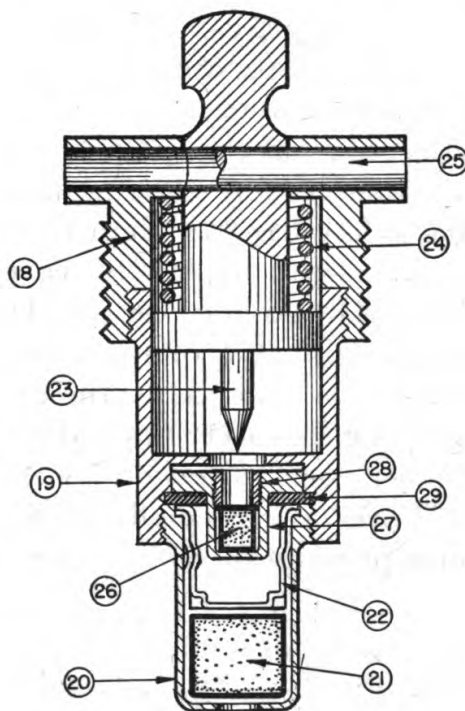

FIGURE 101.

pin (25) which is $\frac{28}{100}$ inch in diameter and shears under a pressure of 420 pounds.

b. Employment.—Mines of this type were used by the Germans against the British in Cyrenaica. They were poorly concealed and rarely covered by fire. As a consequence, the mines were easily removed. The explosive power of the mine is capable of breaking the track of a tank but will not, normally, breach the belly of a tank or injure its crew.

c. Operation.—When the mine is laid in place and is in the armed position, the safety bar (14) has been removed and the cover (4) rests on the striker heads (23) at the cups (13). Pressure exerted on the cover is transmitted to either or both the striker heads and shears

either or both the shear pins (25). This action releases the striker which is driven downward by the pressure of the spring (24) and causes it to fire the percussion cap (26). The concussion of the cap sets off the detonator (21) which fires the booster charge (7), resulting in the explosion of the main charge (9).

d. To disarm.—Carefully detach the loop (3) of the chain (2) from the clip (17) of the cover (4) and lift the cover slowly off the container (1). Unscrew and remove the igniter assemblies (6), taking care that no pressure is applied to the striker heads (23). Replace the cover (4). The igniter assemblies (6) should be kept separate from the mines and handled with care, remembering that the detonators (21) are still in place. The mine should be examined to see if there are any booby traps attached to the mine which would explode with the lifting of the mine cover.

e. To arm.—Lift the cover off the container and insert the igniter assemblies (6) into the tubes (5) by screwing them by hand and without force. Insert the safety bar (14) into the cover and lock it in place with the safety pin (15). Replace the cover over the container so that the safety bar (14) straddles the striker heads. Fasten the loop of the chain to the clip (17) of the cover. The mine is now safe to be transported to the site. After the mine is laid, it is completely armed by extracting the safety pin and withdrawing the safety bar. The cover will then come to rest on the striker heads which fit into the cups (13). Cover and camouflage the mine, being careful not to exert any undue pressure on it.

INDEX

	Paragraph	Page
Aerial bomb, 2-kg	92	143
Antipersonnel mines:		
Definition	9	9
German	48	67
Italian	89-93	134
Antipersonnel mining	4	3
Antitank mines:		
French	102	161
German	43-46	43
Italian	76-87	98
Japanese	97-101	153
Antitank mining practice	5	3
B-2, type	77-79	102
B-4, type	89	134
Bomb, 2-kg aerial	92	143
Booby traps:		
Definition	4, 14-19	3, 10
German	66-69	86
Italian	95	151
Bore-hole charge, model 28	37	39
Brettstuckminen (board mines)	64	83
Burhenn-minen (Burhenn's mines)	54	73
Charges, prepared	36-42	38
Circular variable pressure mine	87	128
Combined igniter, Z. D. Z. 29	30	28
D, type	82	117
Definitions	6	3
Demolition charges	42	41
Disarming	18	12
Detection	17	11
Detonators:		
German	33-35	36
Japanese	96	152
Druckbohlenmine (pressure plank mine)	51	70
Druckbrettmine (pressure board mine)	65	84
Dual purpose mine	94	149
Dummy	13	10
Electric detonators	35	37
Electric mine, type 2	83, 93	120, 146
Elektrischminen (electric mines)	58	78
Employment	16	11
Exploder, grenade	86	126
Exploding nets	72	91
Explosive charge, model 28	38	39
Field mines	12, 94	9, 149
Fields, mine	70-73	88

INDEX

	Paragraph	Page
Firing devices (igniters):		
German.....	22-32	15
Japanese.....	96	152
French type mines.....	102	161
Friction igniter:		
German:		
Delay pellets:		
B. Z. 24.....	25	18
B. Z. E.....	24	17
NB B. Z. 38.....	25	18
Zdschn. Auz. 29.....	23	15
Japanese.....	96	152
Fuszschlingenmine (foot snare mine).....	62	81
German land mines and devices.....	20-73	14
Glossary.....	6	3
Grenade exploder.....	86	126
Grenade mine, stick.....	59	80
Hangemine (handing mine).....	56	76
Heavy antitank.....	8, 46	9, 53
High-explosive shell, antitank.....	50	70
Igniters:		
German.....	22-32	15
Japanese.....	96	152
Improvised.....	10, 49-65	9, 70
Italian land mines.....	74-95	97
Japanese land mines and devices.....	96-101	152
Kammeiermine (kammeier's mine).....	52	72
Land mine, railway type.....	88	132
Lay-outs, mine field.....	71	89
Light antitank.....	7, 43-45	9, 43
L. P. Z. antitank mine.....	45	50
Magnetic antitank mine.....	101	158
Marking booby traps.....	69	88
Metal container HE (high explosive) charge, model 24.....	39	39
Metal tube.....	85	125
Mine fields.....	70-73	88
N-5, type.....	76	98
N type, improvised.....	81	115
Neutralization.....	18	12
Nonelectric detonators.....	34	36
Operation.....	15	11
Passage of mine fields.....	3	3
Precautions.....	19	13
Pressure igniter:		
D. Z. 35.....	28	24
S. Mi. Z. 35.....	29	26
T. Mi. Z. 35.....	31	31
Pressure-operated.....	91	141

INDEX

	Paragraph	Page
Pull igniter:		
Z. U. Z. Z. 35.....	27	21
Z. Z. 35 (mechanical).....	26	20
Purpose.....	1	2
Push igniter, 1942 pattern, model Reinhard.....	32	35
Railway:		
Definition.....	11	9
German.....	47	64
Italian.....	88	132
Rampenmine (ramp mine).....	53	72
References.....	2	2
Removal.....	18	12
Ring charge.....	41	39
Road and field.....	12, 94	9, 149
Schleudermine (sliding mine).....	57	77
Schlusselmine (key mine).....	55	74
Scope.....	1	2
Shells, HE (high explosive).....	50	70
Standard firing devices (igniters).....	22-32	15
Stick grenade mine.....	59, 60	80
Stolpendrahtmine (stick or block wire mine).....	61	81
Summary of German mine field practice.....	73	92
Tellermine—"T" mine.....	44	43
Tension wire igniter, Z. U. Z. Z. 35.....	27	21
Tension-operated.....	90	138
Three-kilogram HE (high explosive) charge.....	40	39
Tretmine (tread mine).....	63	82
Types of mines:		
Definitions.....	7-13	9
German.....	21	15
Italian.....	75	97

[A. G. 062.11 (2-2-43).]

BY ORDER OF THE SECRETARY OF WAR:

G. C. MARSHALL,
Chief of Staff.

OFFICIAL:

J. A. ULIO,
Major General,
The Adjutant General.

Distribution:

R and H (3) ; Bn and L 2, 6, 7, 17, 18, 44, (2), 5 (3).
(For explanation of symbols see FM 21-6.)

